

# 26 - COOLING SYSTEM

## CONTENTS

Page

### LAND ROVER V8

#### DESCRIPTION AND OPERATION

ENGINE COOLING - DESCRIPTION .....	3
ENGINE COOLING - OPERATION .....	9

#### FAULT DIAGNOSIS

COOLING SYSTEM FAULTS .....	1
-----------------------------	---

#### REPAIR

COOLANT - DRAIN AND REFILL .....	1
RADIATOR .....	2
VISCOUS COUPLING AND FAN ASSEMBLY - UP TO 99MY .....	4
VISCOUS COUPLING AND FAN ASSEMBLY - FROM 99MY .....	5
WATER PUMP - UP TO 99MY .....	6
WATER PUMP - FROM 99MY .....	7
THERMOSTAT - UP TO 99MY .....	8
THERMOSTAT - FROM 99MY .....	8
EXPANSION TANK .....	9







V8 cooling system component layout - up to 99MY

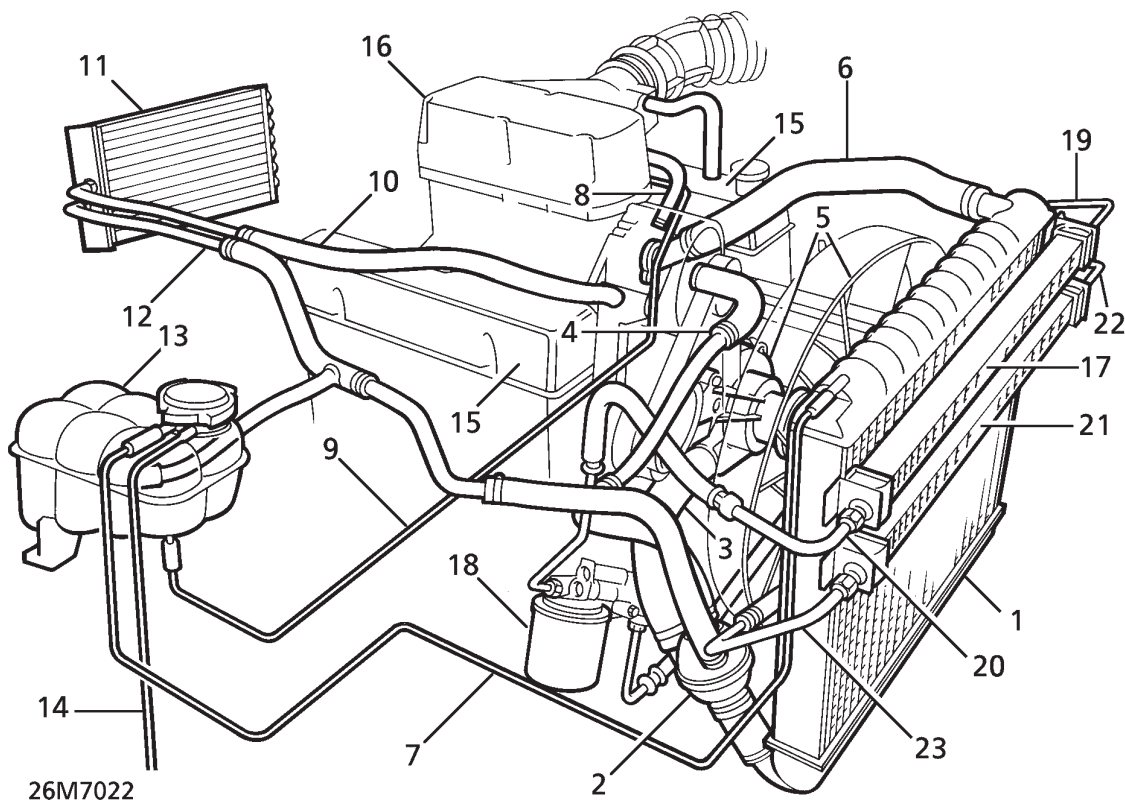

- |                               |                                     |
|-------------------------------|-------------------------------------|
| 1. Radiator                   | 13. Expansion tank                  |
| 2. Thermostat housing         | 14. Overflow/Breather pipe          |
| 3. Bottom hose                | 15. Cylinder banks                  |
| 4. Bypass hose                | 16. Plenum chamber                  |
| 5. Viscous fan and water pump | 17. Engine oil cooler               |
| 6. Radiator top hose          | 18. Engine oil filter               |
| 7. Radiator bleed pipe        | 19. Feed pipe, engine oil cooler    |
| 8. Plenum chamber feed pipe   | 20. Return pipe, engine oil cooler  |
| 9. Plenum chamber bleed pipe  | 21. Gearbox oil cooler              |
| 10. Heater feed hose          | 22. Feed pipe, gearbox oil cooler   |
| 11. Heater matrix             | 23. Return pipe, gearbox oil cooler |
| 12. Heater return hose        |                                     |

## V8 cooling system component layout - from 99MY

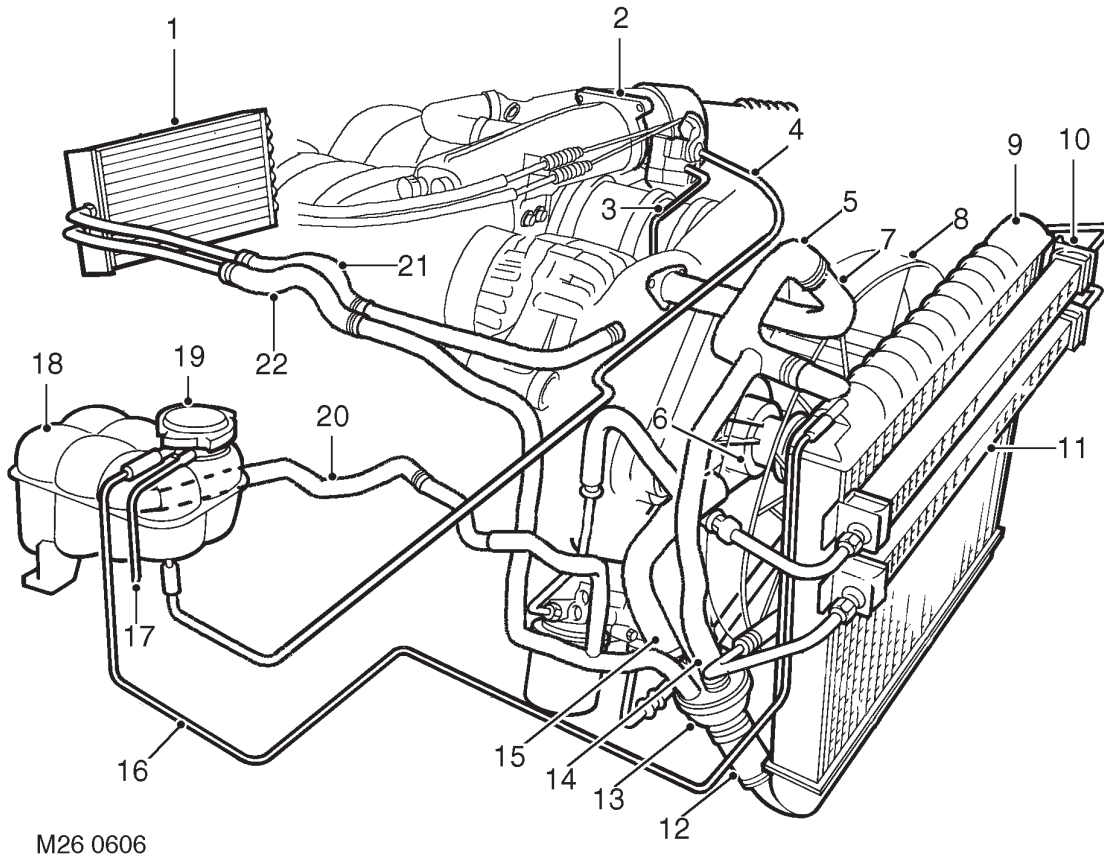

M26 0606

- |                                 |                             |
|---------------------------------|-----------------------------|
| 1. Heater matrix                | 12. Radiator bottom hose    |
| 2. Throttle housing             | 13. Thermostat housing      |
| 3. Throttle housing inlet hose  | 14. By-pass hose            |
| 4. Throttle housing return pipe | 15. Coolant pump feed hose  |
| 5. Radiator top hose            | 16. Radiator bleed pipe     |
| 6. Coolant pump                 | 17. Overflow/breather pipe  |
| 7. Manifold outlet pipe         | 18. Expansion tank          |
| 8. Viscous fan                  | 19. Pressure cap            |
| 9. Radiator                     | 20. Expansion hose          |
| 10. Engine oil cooler           | 21. Heater inlet hose/pipe  |
| 11. Gearbox oil cooler          | 22. Heater return hose/pipe |



## ENGINE COOLING - DESCRIPTION

### General

The complete cooling system installed in vehicles with V8 engines incorporates three independent functions:- Engine (coolant) cooling; Engine oil cooling; Gearbox oil cooling.

Engine and gearbox oil coolers are mounted in front of the radiator and linked to their separate systems by pre-formed pipes and hoses.

The cooling system used on the V8 engine is a pressurised, by-pass type system which allows coolant to circulate around the engine block and heater matrix when the thermostat is closed. With coolant not passing through the radiator, faster heater warm-up is promoted which in turn improves passenger comfort.

A coolant pump is located in a housing at the front of the engine and is driven by a drive belt. The water pump is connected into the coolant passages cast into the cylinder block and pumps coolant from the radiator through the cylinder block and heater circuit.

A viscous fan is attached to the water pump drive pulley. The fan is secured by a left hand threaded nut to the pulley spindle. The fan draws air through the radiator to assist in cooling when the vehicle is stationary. The fan rotational speed is controlled relative to the running temperature of the engine by a thermostatic valve regulated by a bi-metallic coil.

The cooling system uses a 50/50 mix of anti-freeze and water.

### Thermostat housing

A 'four way' thermostat housing, located at the bottom of the fan cowl behind the radiator, is used to link the main components within the engine cooling system. The four connections locate the radiator bottom hose, top hose, by-pass hose and coolant pump feed hose.

The plastic housing contains a wax element thermostat. The thermostat and housing are a sealed unit and cannot be replaced individually. The thermostat is used to maintain the coolant at the optimum temperature for efficient combustion and to aid engine warm-up.

The thermostat is closed at temperatures below approximately 80 °C (176 °F). When the coolant temperature reaches between 80 to 84 °C (176 to 183 °F) the thermostat starts to open and is fully open at approximately 96 °C (204 °F). In this condition the full flow of coolant is directed through the radiator.

### Inlet manifold cooling connections

With the thermostat open, coolant leaves the cylinder block via an outlet pipe and top hose attached to the front of the inlet manifold. The top hose is connected to the top of the radiator.

Hot coolant from the cylinder block is also directed from the inlet manifold via pipes and hoses to the heater matrix. Coolant is circulated through the heater matrix at all times when the engine is running.

### Plenum chamber - up to 99MY

The plenum chamber is heated with a supply of coolant from a supply pipe from the inlet manifold to a plate on the underside of the throttle on the plenum. The hot coolant prevents the air intake and throttle linkage from icing. A bleed pipe returns coolant from the plenum chamber to the expansion tank.

### Throttle housing - from 99MY

A tapping from the inlet manifold supplies coolant to the throttle housing via a hose. The coolant circulates through a plate attached to the bottom of the throttle housing and is returned through a plastic bleed pipe to the expansion tank. The hot coolant heats the throttle housing preventing ice from forming.

***ECT sensor and temperature gauge sender unit - up to 99MY***

An Engine Coolant Temperature (ECT) sensor and a temperature gauge sender unit are located on the inlet manifold adjacent to the outlet pipe. The ECT sensor monitors coolant temperature emerging from the engine and sends signals relating to coolant temperature to the ECM for engine management. The temperature gauge sender unit operates the warning lamp and temperature gauge in the instrument pack. **See FUEL SYSTEM - Engine Management, Description and operation.**

***ECT sensor - from 99MY***

An Engine Coolant Temperature (ECT) sensor is located on the inlet manifold adjacent to the outlet pipe. The ECT sensor monitors coolant temperature emerging from the engine and sends signals relating to coolant temperature to the ECM for engine management and to the instrument pack for temperature gauge operation. **See FUEL SYSTEM - Engine Management, Description and operation.**

**Expansion tank**

The expansion tank is located in the engine compartment and attached to the right hand inner wing. The tank is made from moulded plastic and has a maximum coolant level when cold mark moulded on the side.

Excess coolant created by heat expansion is returned to the expansion tank from the bleed pipe at the top of the radiator. An outlet pipe is connected into the thermostat housing and replaces coolant displaced by heat expansion into the system when the engine is cool.

The tank is fitted with a sealed pressure cap. The cap contains a pressure relief valve which opens to allow excessive pressure and coolant to vent through the overflow pipe. The relief valve opens at a pressure of 1.4 bar (20 lbf.in) and above.

**Heater matrix**

The heater matrix is fitted in the distribution unit of the heating and ventilation system inside the passenger compartment. Two pipes pass through the bulkhead and provide coolant flow to and from the matrix.

The matrix is constructed from aluminium with two end tanks interconnected with tubes. Aluminium fins are located between the tubes and conduct heat away from the hot coolant flowing through the tubes. Air from the heater assembly is warmed as it passes through the matrix fins. The warm air is then distributed into the passenger compartment as required. **See HEATING AND VENTILATION, Description and operation.**

**Radiator**

The radiator is located at the front of the vehicle. The vertical flow radiator is manufactured from aluminium with moulded plastic tanks at the top and bottom, interconnected with tubes. Aluminium fins are located between the tubes and conduct heat from the hot coolant flowing through the tubes, reducing the coolant temperature as it passes through the radiator. Air intake from the front of the vehicle when moving carries heat away from the fins. When the vehicle is stationary, the viscous fan draws air through the fins to prevent the engine from overheating.

Two connections at the top of the radiator provide for the attachment of the top hose and bleed pipe. A connection at the bottom of the radiator allows for the attachment of the bottom hose to the thermostat housing.

Two coolers are located in front of the cooling radiator. The upper cooler provides cooling of the engine oil and the lower cooler provides cooling for the gearbox oil.

**See MANUAL GEARBOX, Description and operation.**

**See AUTOMATIC GEARBOX, Description and operation.**

**See ENGINE, Description and operation.**

**Pipes and hoses**

The coolant circuit comprises flexible hoses and metal formed pipes which direct coolant into and out of the engine, radiator and heater matrix. Plastic pipes are used for the bleed and overflow pipes to the expansion tank.

A drain plug is fitted to each cylinder bank in the cylinder block. These are used to drain the block of coolant.



## Coolant pump

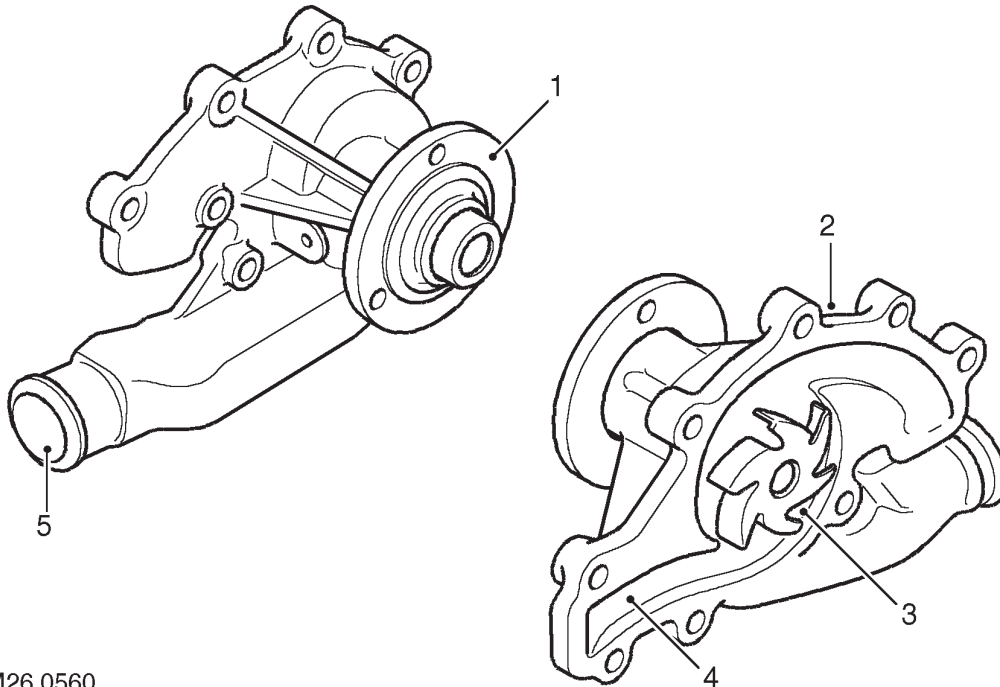

M26 0560

1. Pulley flange
2. Body
3. Impeller

4. Gallery
5. Inlet connection

The coolant pump is attached to the front of the cylinder block with nine bolts and sealed between the pump housing and the cylinder block with a gasket. The pump comprises a shaft which passes through an alloy housing.

The outer end of the shaft has a flange which allows for the attachment of the pump drive pulley which is secured with three bolts. The drive pulley is driven by the grooved auxiliary drive belt and rotates at the same speed as the crankshaft. The inner end of the shaft is fitted with an impeller which draws coolant from the thermostat housing and circulates it through galleries in the cylinder block and through the heater matrix.

The shaft is supported on bearings in the housing which are packed with grease and sealed for life. A seal is positioned in the housing to further protect the bearings from the ingress of coolant. The seal is manufactured from a synthetic material which will allow for the expansion of the casing when hot coolant is present.

The cast alloy housing has a hose connection which provides the attachment for the coolant pump feed hose. The housing connects with galleries in the cylinder block and distributes coolant from the pump impeller into the galleries and water jackets.

**Viscous fan**

The viscous drive unit for the engine cooling fan provides a means of controlling the speed of the fan relative to the temperature of the engine. The viscous fan unit is a type of fluid coupling, which drives the fan blades by means of 'silicon fluid'.

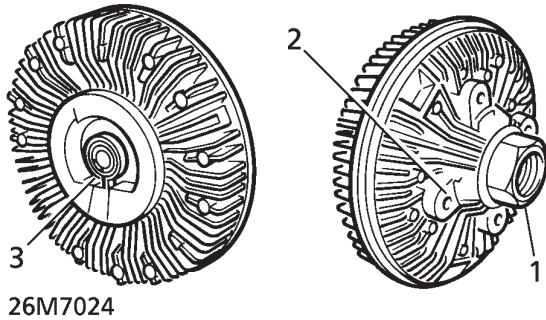

1. Input (drive) member
2. Output (driven) member
3. Sensing mechanism (bi-metal coil)





Cooling system coolant flow - up to 99MY

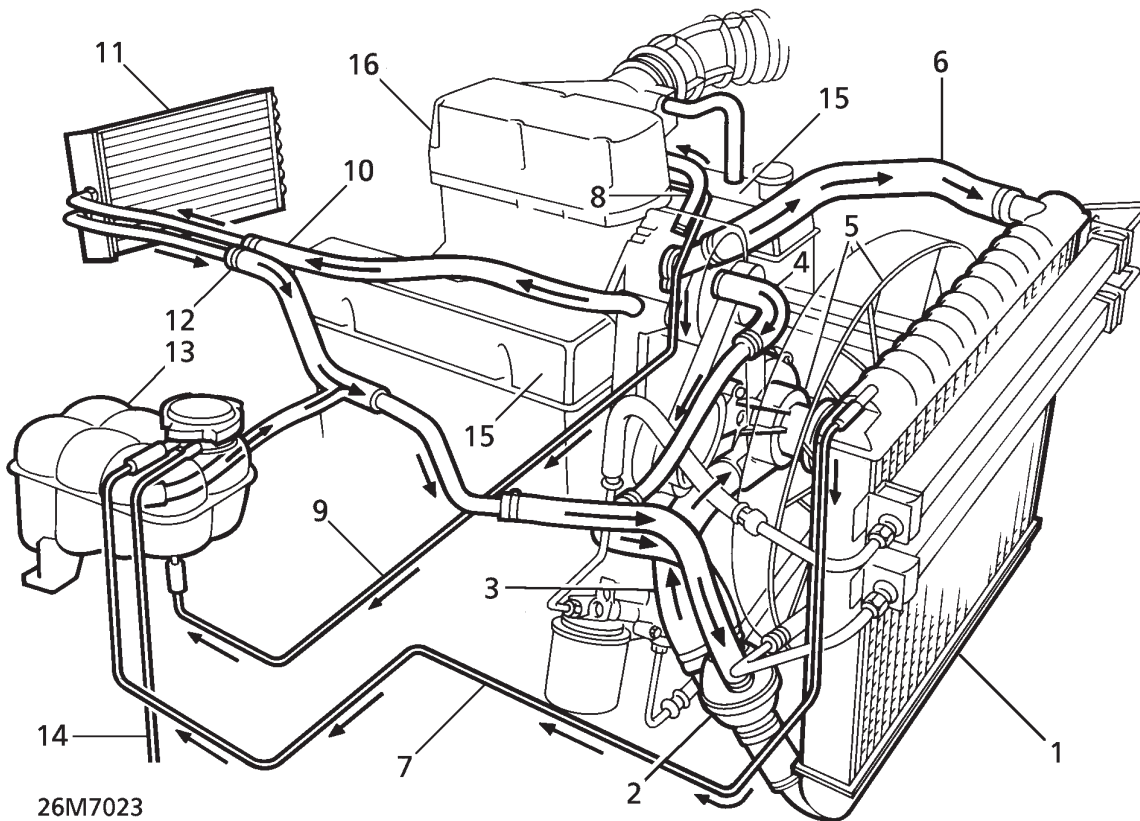

26M7023

- |                               |                              |
|-------------------------------|------------------------------|
| 1. Radiator                   | 9. Plenum chamber bleed pipe |
| 2. Thermostat housing         | 10. Heater feed hose         |
| 3. Bottom hose                | 11. Heater matrix            |
| 4. Bypass hose                | 12. Heater return hose       |
| 5. Viscous fan and water pump | 13. Expansion tank           |
| 6. Radiator top hose          | 14. Overflow/breather pipe   |
| 7. Radiator bleed pipe        | 15. Cylinder banks           |
| 8. Plenum chamber feed pipe   | 16. Plenum chamber           |

## Cooling system coolant flow - from 99MY

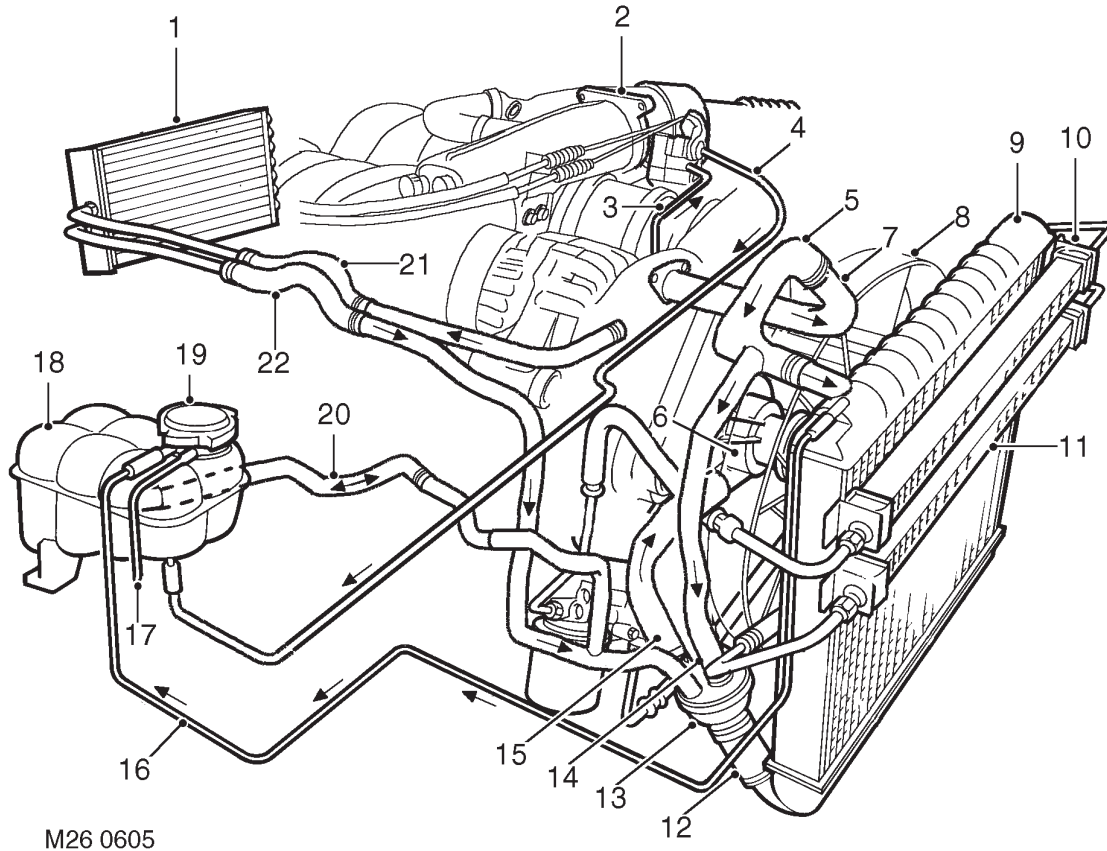

- |                                 |                             |
|---------------------------------|-----------------------------|
| 1. Heater matrix                | 12. Radiator bottom hose    |
| 2. Throttle housing             | 13. Thermostat housing      |
| 3. Throttle housing inlet hose  | 14. By-pass hose            |
| 4. Throttle housing return pipe | 15. Coolant pump feed hose  |
| 5. Radiator top hose            | 16. Radiator bleed pipe     |
| 6. Coolant pump                 | 17. Overflow/breather pipe  |
| 7. Manifold outlet pipe         | 18. Expansion tank          |
| 8. Viscous fan                  | 19. Pressure cap            |
| 9. Radiator                     | 20. Expansion hose          |
| 10. Engine oil cooler           | 21. Heater inlet hose/pipe  |
| 11. Gearbox oil cooler          | 22. Heater return hose/pipe |



---

## ENGINE COOLING - OPERATION

---

### Coolant flow

#### *Engine warm up - up to 99MY*

When the engine is started from cold, the thermostat, integral in the housing, prevents any coolant circulation through the radiator by closing off the supply from the radiator bottom hose.

During engine warm up, the water pump moves coolant around the cylinders to the rear of the engine block and along the galleries in both cylinder banks. At the rear of the cylinder block the coolant rises through a large port in both cylinder head/block joint faces to the inlet manifold.

From the manifold, the coolant flow is divided between the by-pass hose, the heater feed hose and the plenum chamber feed pipe. The heater feed hose supplies the heater matrix, located within the distribution unit of the heating and ventilation system. The coolant is then carried, via the heater return hose, back to the thermostat housing to complete the cycle.

The heater matrix acts as a heat exchanger reducing coolant temperature as it passes through the matrix. With the thermostat closed and coolant flowing around the by-pass circuit, the cooling system is operating at maximum heater performance.

The plenum chamber is heated by a flow of coolant through the feed pipe from the inlet manifold. A bleed pipe returns the coolant from the plenum chamber across the engine to the expansion tank.

#### *Engine hot - up to 99MY*

When normal engine running temperature is reached, the main valve of the thermostat opens and a secondary valve closes the bypass port. With the thermostat open, coolant is circulated through the top hose to the radiator.

The air flowing between the tubes cools the coolant as it passes through the radiator. A controlled flow of the lower temperature coolant is drawn from the base of the radiator, through the bottom hose, by the water pump and blended with hot coolant returning from the heater matrix. Coolant circulation through cylinder block and cylinder heads to the heater matrix and plenum chamber remains the same.

Coolant is drawn from the base of the radiator, through the bottom hose, by the water pump. Coolant circulation through the cylinder block and cylinder heads to the heater matrix and plenum chamber remains the same.

An integral bleed pipe connects the top of the radiator to the expansion tank and aids bleeding of air from the coolant system. The expansion tank cap contains a pressure valve which allows excessive pressure and coolant to vent to the overflow pipe if the system has been overfilled.

#### *Engine warm up - from 99MY*

When the engine is started from cold, the thermostat, integral in the housing, prevents any coolant circulation through the radiator by closing off the supply from the radiator bottom hose.

During engine warm up, the water pump moves coolant around the cylinders to the rear of the engine block and along the galleries in both cylinder banks. At the rear of the cylinder block the coolant rises through a large port in both cylinder head/block joint faces to the inlet manifold.

From the manifold, the coolant flow is divided between the outlet pipe and the top hose by-pass connection to the thermostat housing, the heater inlet pipe and hose and the throttle housing inlet hose.

The heater inlet pipe and hose supply the heater matrix, located within the distribution unit of the heating and ventilation system. The coolant is then carried, via the heater return hose and pipe, back to the thermostat housing to complete the cycle.

The heater matrix acts as a heat exchanger reducing coolant temperature as it passes through the matrix. With the thermostat closed and coolant flowing around the by-pass circuit, the cooling system is operating at maximum heater performance.

The throttle housing inlet hose allows coolant to flow from the inlet manifold to the plate attached to the bottom of the throttle housing. A return pipe directs coolant flow from the throttle housing to the expansion tank.

**Engine hot - from 99MY**

When normal engine running temperature is reached, the main valve of the thermostat opens and a secondary valve closes the bypass port from the top hose. With the thermostat open, coolant is circulated through the top hose to the radiator.

The air flowing between the tubes cools the coolant as it passes through the radiator. A controlled flow of the lower temperature coolant is drawn from the base of the radiator, through the bottom hose, by the water pump and blended with hot coolant returning from the heater matrix. Coolant circulation through the cylinder block and cylinder heads to the heater matrix and throttle housing remains the same.

A bleed pipe connects the top of the radiator to the expansion tank and aids bleeding of air from the coolant system. The expansion tank cap contains a pressure valve which allows excessive pressure and coolant to vent to the overflow pipe if the system has been overfilled.

**Viscous fan**

There are two main components of the viscous fan drive : An input (drive) member consisting of a threaded shaft passing through a bearing into the clutch plate and secured to the water pump. An output (driven) member comprises the main body to which the fan attaches, with the temperature sensing mechanism (bi-metal coil) and pump plates.

The fan drive only has to be engaged periodically, between 5% and 10% of the time during normal driving conditions, because usually the vehicle is cooled by ram air.

A bi-metal coil senses air temperature behind the radiator. When a pre-determined temperature is reached, the coil opens a valve which allows fluid to enter the drive area. Centrifugal force circulates the fluid to the annular drive area. There are two sets of annular grooves, one in the drive clutch and the other in the drive body, a specific clearance being provided between the two sets of grooves. When this clearance is filled with viscous fluid a shearing action, caused by the speed differential between the two drive components, transmits torque to the fan. The fluid is thrown to the outside of the unit by centrifugal force from where it is then re-circulated to the reservoir via the pump plate adjacent to the drive member.

If the engine speed is increased, the amount of slip will also increase to limit the maximum fan speed.

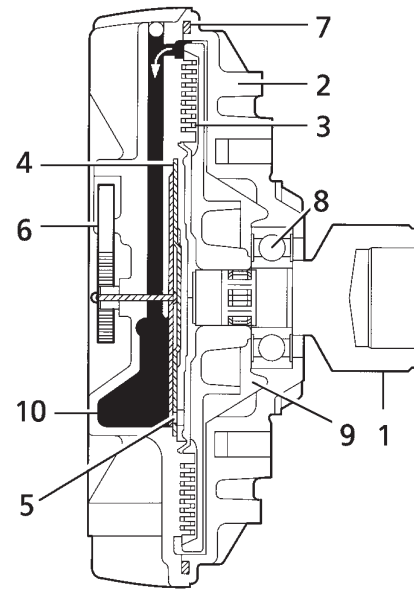
**Viscous unit disengaged (engine at normal operating temperature)**

26M7025

1. Input (drive) member
2. Output (driven) member
3. Running clearance
4. Pump plate
5. Valve (closed)
6. Sensing mechanism (bi-metal coil)
7. Fluid seal
8. Bearing, input member
9. Fluid chamber
10. Fluid reservoir



**Viscous unit engaged (hot running temperature)**

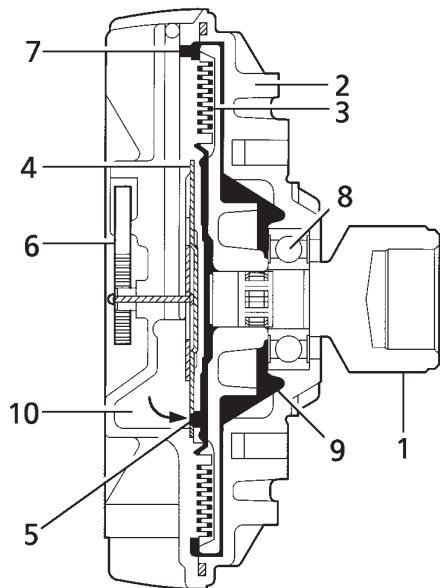

26M7026

Bi-metal coil expanded, valve open.

When the air temperature from the radiator drops sufficiently, the bi-metal coil closes the valve and prevents fluid entering the drive area, see 26M7026. The fluid that is in the drive area will gradually pump out into the reservoir and the fan will return to an idle condition.

**Engine oil cooler**

The engine oil cooler is located in front of the radiator above the gearbox oil cooler and comprises a single row matrix; on 4.0 litre models three internal cooling tubes are used; 4.6 litre models use a larger matrix incorporating six cooling tubes. Pre-formed feed and return pipes/hoses are used to link the cylinder block, oil filter and oil cooler. The oil cooler is mounted above the gearbox oil cooler, fixed to the radiator side frame.

Oil drawn through a steel gauze strainer in the sump, is pumped under pressure through the feed pipe into the oil cooler. Ambient air, forced through the front grille of the vehicle and assisted by the pull of the viscous fan, is dispersed across the oil cooler. The cooled oil then passes through the return pipe to the filter, before being distributed from the cylinder block to the various internal engine components.

**Engine oil cooler - up to 99MY shown**

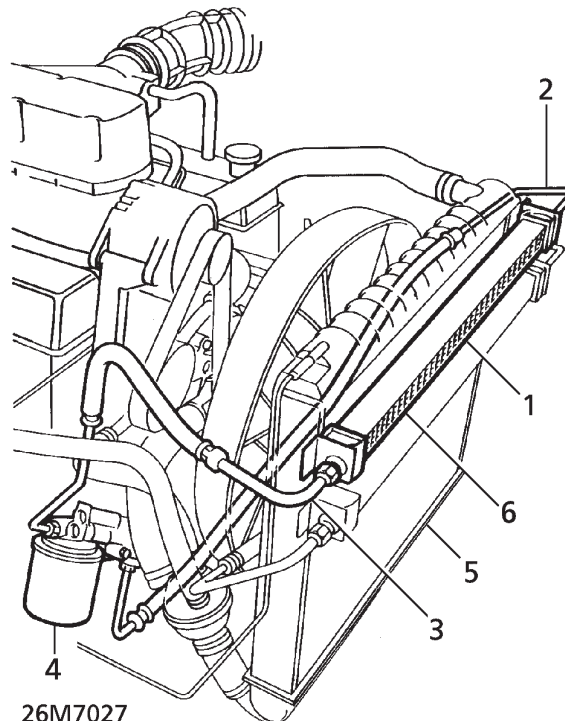

26M7027

- 1. Engine oil cooler
- 2. Feed pipe
- 3. Return pipe
- 4. Oil filter
- 5. Radiator
- 6. Gearbox oil cooler

### Gearbox oil cooler

The gearbox oil cooler is located below the engine oil cooler in front of the radiator and comprises a single row matrix. On vehicles fitted with manual gearboxes three internal cooling tubes are used, on vehicles with automatic transmission a larger matrix, incorporating twelve coolant tubes is fitted. Pre-formed feed and return pipes/hoses are used to link the gearbox and oil cooler.

Oil is pumped under pressure from the gearbox through the feed pipe into the oil cooler. Ambient air, forced through the front grille of the vehicle and assisted by the pull of the viscous fan, is dispersed over the oil cooler. The cooled oil then passes through the return pipe, which is routed under the engine to run parallel with the feed pipe back to the LH side of the gearbox.

### Gearbox oil cooler - up to 99MY shown

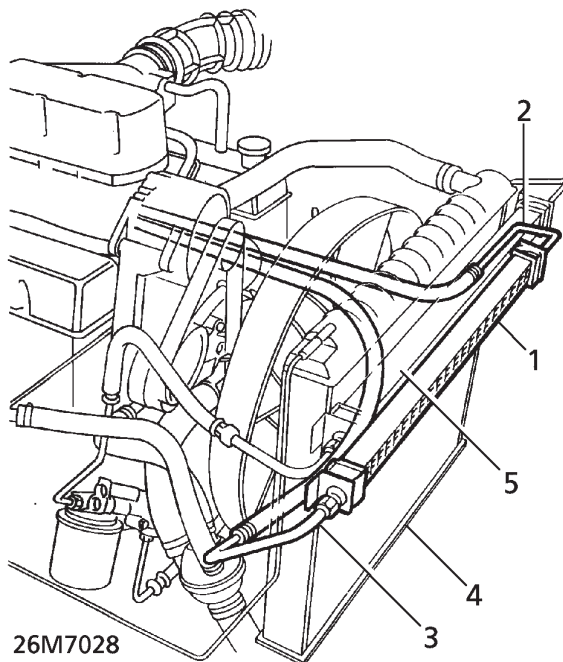

1. Gearbox oil cooler
2. Feed pipe
3. Return pipe
4. Radiator
5. Engine oil cooler



## COOLING SYSTEM FAULTS

This section covers mechanical faults that could occur in the complete cooling system :

1. Engine (coolant) cooling;
2. Engine oil cooling;
3. Gearbox oil cooling.

Before conducting any visual checks within the separate systems and undertaking detailed diagnosis procedures. **See Description and operation.**

### 1. ENGINE (COOLANT) COOLING SYSTEM

#### Symptom - Engine Overheating

POSSIBLE CAUSE	REMEDY
1. Engine coolant low.	1. Allow engine to cool. Top up expansion tank to correct level, with engine running at idle. Check cooling system for leaks and rectify, if necessary.
2. Loose drive belt.	2. Check/renew drive belt tensioner or renew drive belt. <b>See ELECTRICAL, Repair.</b>
3. Coolant in radiator frozen.	3. Slowly thaw and drain cooling system. <b>See Repair.</b>
4. Air flow through radiator restricted or blocked.	4. Apply air pressure to engine side of radiator to clear obstruction. If mud or dirt is evident, carefully use a hose.
5. External leaks from water pump, engine gaskets, thermostat housing or pipe/hoses.	5. Check for visual causes and rectify.
6. Viscous fan not operating correctly or inoperative.	6. Renew viscous fan unit. <b>See Repair.</b>
7. Thermostat seized in closed position.	7. Check radiator bottom hose for coolant flow through radiator. If cold a faulty thermostat is confirmed. Renew thermostat housing assembly. <b>See Repair.</b>

## Symptom - Engine Overheating, continued

POSSIBLE CAUSE	REMEDY
8. Air in cooling system.	8. Check coolant level. Run engine at fast idle (approximately 2,000 rpm) with expansion tank cap off. Top up coolant level with engine at idle and refit expansion tank cap.
9. Air conditioning condenser fans not operating correctly or inoperative.	9. <b>See AIR CONDITIONING, Fault diagnosis.</b>
10. Temperature gauge or sender unit giving inaccurate readings.	10. Substitute parts and compare new readings.
11. Coolant leakage across cylinder head gasket.	11. Carry out cylinder pressure test to determine if pressure is leaking into cooling system, causing over pressurising and loss of coolant. Renew cylinder head gasket.
12. Engine oil contamination of cooling system due to leaking.	12. Renew cylinder head gasket. <b>See ENGINE, Repair.</b>
13. Coolant contamination of lubrication system.	13. Renew inlet manifold or front cover gaskets. <b>See MANIFOLD AND EXHAUST SYSTEM, Repair.</b> or <b>See ENGINE, Repair.</b>

## Symptom - Engine Runs Cold

POSSIBLE CAUSE	REMEDY
1. Thermostat seized in open or partially open position.	1. Remove thermostat housing and check operation of thermostat. Renew, if necessary. <b>See Repair.</b>
2. Temperature gauge or sender unit giving inaccurate readings.	2. Substitute parts and compare new readings.
3. Viscous fan not operating correctly.	3. Renew viscous fan unit. <b>See Repair.</b>
4. Air conditioning condenser fans operating continuously.	4. Refer to <b>TestBook</b> .





## 2. ENGINE OIL COOLING SYSTEM

### Symptom - Engine Oil Overheating

POSSIBLE CAUSE	REMEDY
1. Air flow through oil cooler matrix restricted or blocked.	1. Apply air pressure to engine side of radiator to clear obstruction. If mud or dirt is evident, carefully use a hose.
2. Blocked or damaged oil cooler or pipe/hoses restricting engine oil flow.	2. Check for visual damage and renew components where necessary.
3. Oil cooler relief valve seized in closed position.	3. Remove and check relief valve. Renew, if necessary.

## 3. GEARBOX OIL COOLING SYSTEM

### SYMPTOM - Gearbox Oil Overheating

POSSIBLE CAUSE	REMEDY
1. Air flow through oil cooler matrix restricted or blocked.	1. Apply air pressure to engine side of radiator to clear obstruction. If mud or dirt is evident, carefully use a hose.
2. Damaged oil cooler or pipe/hoses restricting gearbox oil flow.	2. Check for visual damage and renew components where necessary.
3. Vehicle being driven in wrong gear.	3. Advise owner/driver accordingly.



**NOTE:** Critical warning messages relating to the complete cooling system are displayed on the message centre in the lower section of the instrument pack, should a fault occur in any of the separate systems.





**COOLANT - DRAIN AND REFILL**

Service repair no - 26.10.01

**Drain**



**WARNING:** Do not remove expansion tank filler cap when engine is hot. The cooling system is pressurised. Personal scalding could result.

1. Raise the vehicle.



**WARNING:** Support on safety stands.

2. Remove expansion tank filler cap to assist draining.

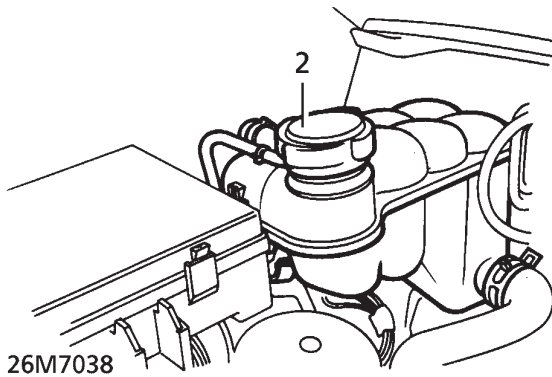

3. Position container beneath radiator.
4. Remove plug from base of radiator. Allow coolant to drain.

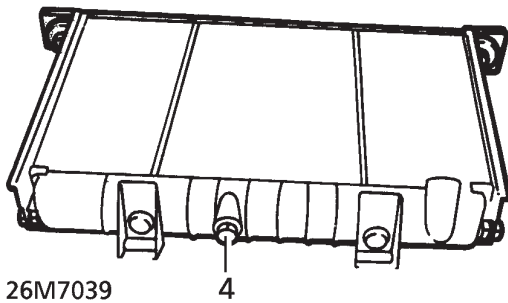

5. If system is only being partially drained, continue at **Refill**.
6. Reposition container. Remove LH cylinder block drain plug. Allow coolant to drain.

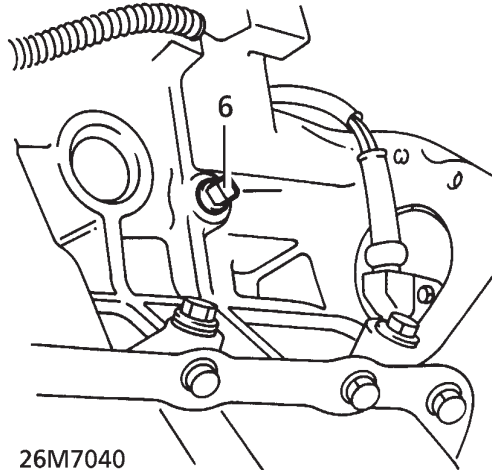

**NOTE:** Do not remove RH cylinder block drain plug.

7. Clean drain plug threads. Apply a coating of 'Loctite 577'. Refit plug to block. Tighten securely.

## Refill

8. Ensure sufficient coolant solution is available.  
*See LUBRICANTS, FLUIDS AND CAPACITIES, Information.*
9. Inspect radiator drain plug 'O' ring, renew if required.
10. Fit drain plug to radiator. Tighten to **Max 6 Nm (4 lbf.ft)**
11. Remove safety stands. Lower vehicle.
12. Disconnect radiator bleed hose at the radiator.
13. Blow through hose to clear any residual coolant. Reconnect hose.



**CAUTION: If radiator bleed hose is not cleared of coolant, air may become trapped at top of radiator during refill, leading to subsequent engine overheating.**

14. Fill expansion tank until coolant is level with base of neck.
15. Start engine, continue filling at expansion tank until coolant level stabilises at the 'COLD LEVEL' marking.
16. Run the engine until the thermostat opens (top hose becomes warm).
17. Stop engine, allow to cool.
18. Check coolant level, top-up as necessary.
19. Refit expansion tank filler cap.

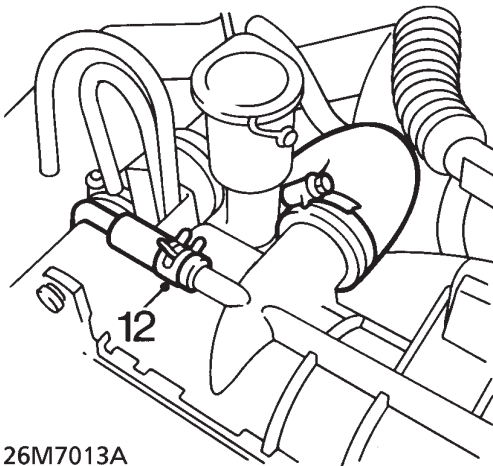

26M7013A

## RADIATOR

Service repair no - 26.40.04

## Remove

1. Disconnect battery negative lead.
2. Raise the vehicle.



**WARNING: Support on safety stands.**

3. Drain cooling system. *See this section.*
4. Release clips securing upper cooling fan cowl. Remove cowl.

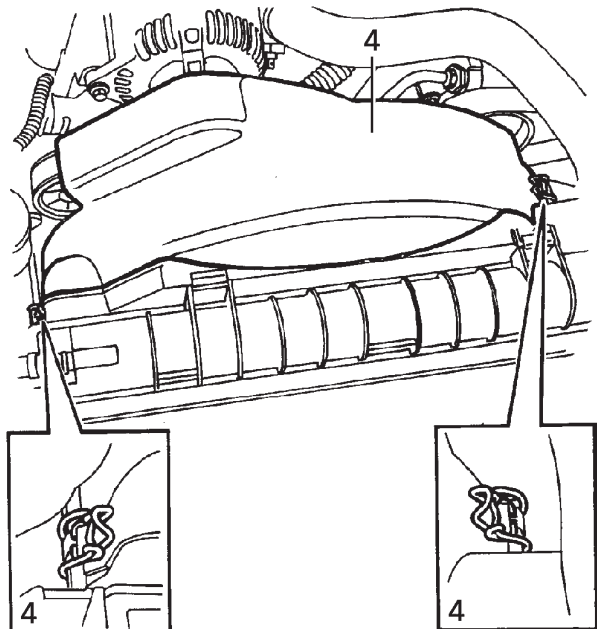

26M7008

5. Release top hose from radiator.
6. Release expansion tank hose from radiator.

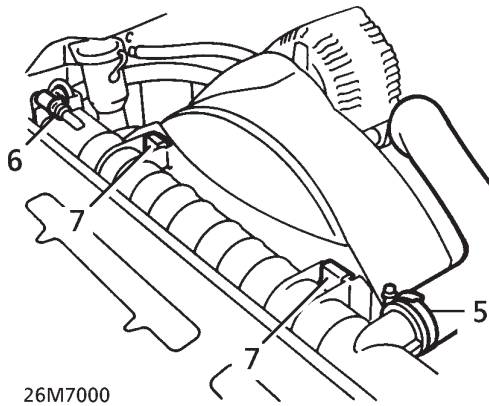

7. Remove clips securing radiator to cooling fan cowl.

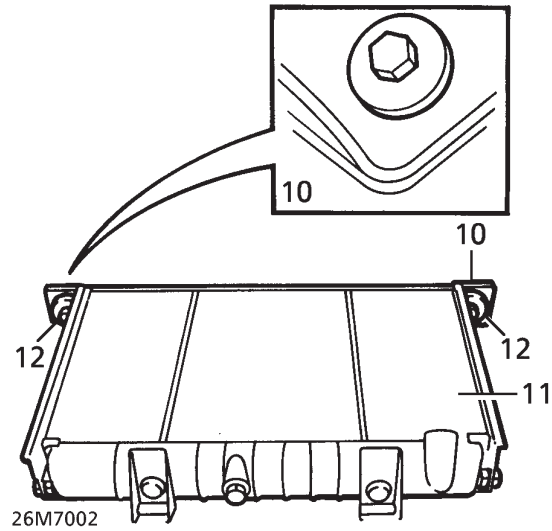

- 11. Release radiator from upper and lower mountings.
- 12. Remove radiator. Collect lower mounting rubbers.

**Refit**

- 13. Reverse removal procedure.
- 14. Refill cooling system. **See this section.**

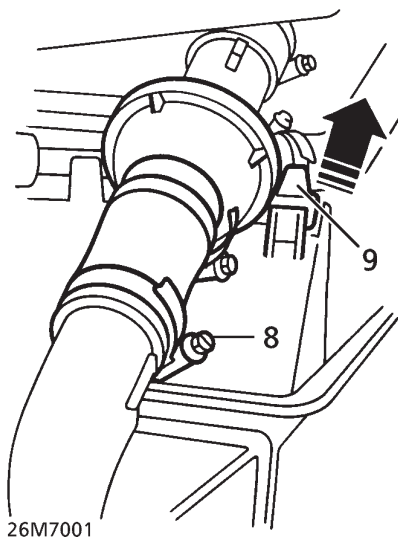

- 8. Slacken bottom hose clips at radiator and thermostat housing.
- 9. Release thermostat housing from fan cowl. Remove bottom hose.
- 10. Remove 2 bolts securing radiator to mounting bracket.

### VISCOUS COUPLING AND FAN ASSEMBLY - UP TO 99MY

Service repair no - 26.25.19

#### Special tools:

LRT-12-093

LRT-12-094 - Viscous coupling removal

#### Remove

1. Disconnect battery negative lead.

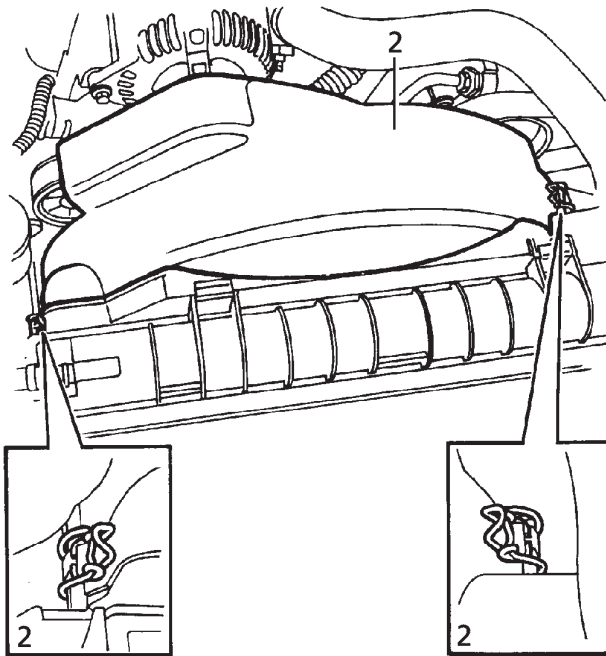

26M7005

2. Release 2 clips securing cooling fan upper cowl. Remove cowl.

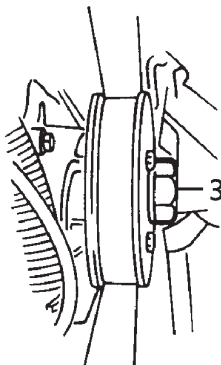

26M7006

3. Using LRT-12-093 and LRT-12-094 unscrew viscous coupling from water pump.



**NOTE:** Viscous coupling is secured with a RH thread.

4. Remove fan and coupling assembly.

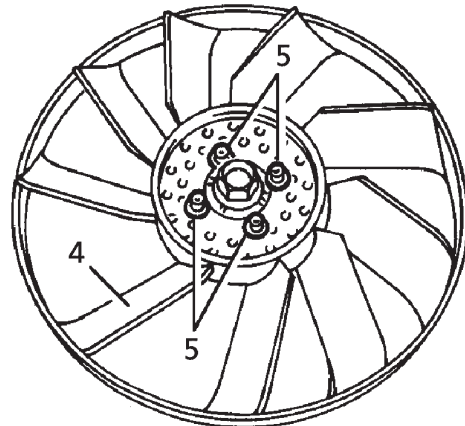

26M7007

**Do not carry out further dismantling if component is removed for access only.**

5. Remove 4 bolts securing coupling to fan. Remove coupling.

#### Refit

6. Ensure mating faces are clean.
7. Fit fan to coupling. Secure with bolts. Tighten to **24 Nm (18 lbf.ft)**
8. Using LRT-12-093 and LRT-12-094, fit fan assembly to pump. Tighten to **56 Nm (41 lbf.ft.)**
9. Fit cooling fan upper cowl. Secure with clips.
10. Reconnect battery negative lead.



**VISCOUS COUPLING AND FAN ASSEMBLY - FROM 99MY**

Service repair no - 26.25.19

**Remove**

1. Release fixings and remove battery cover.
2. Disconnect battery earth lead.

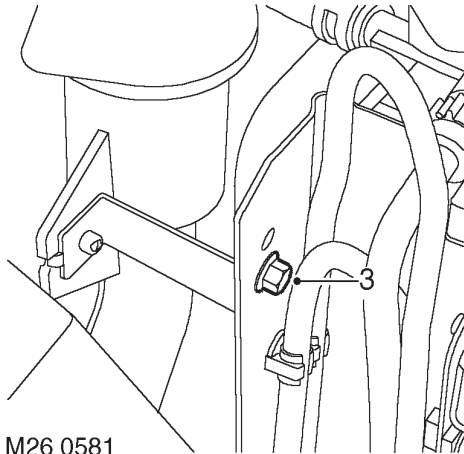

M26 0581

3. Remove bolt securing washer reservoir filler tube support bracket to radiator bracket.

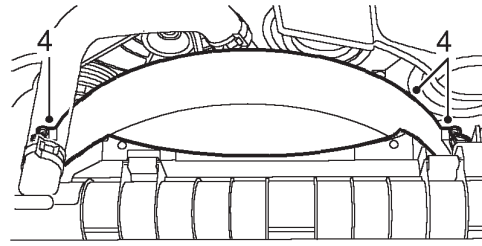

M26 0582

4. Release 2 clips securing fan cowl and remove fan cowl.

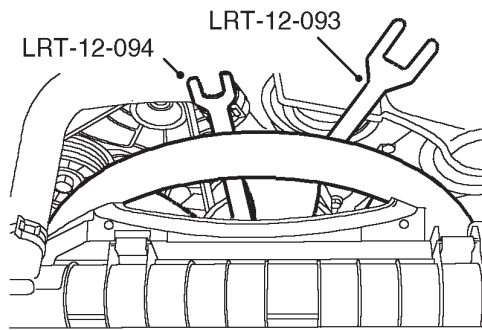

M26 0583

5. Remove cooling fan using LRT-12-093 and LRT-12-094.

**Refit**

6. Position cooling fan and tighten using LRT-12-093 and LRT-12-094.
7. Fit fan cowl and secure with clips.
8. Align washer reservoir filler tube bracket and secure with bolt.
9. Connect battery earth lead.
10. Fit battery cover and secure with fixings.

**WATER PUMP - UP TO 99MY**

Service repair no - 26.50.01

**Remove**

1. Drain cooling system. *See this section.*
2. Remove cooling fan. *See this section.*
3. Slacken water pump pulley bolts.

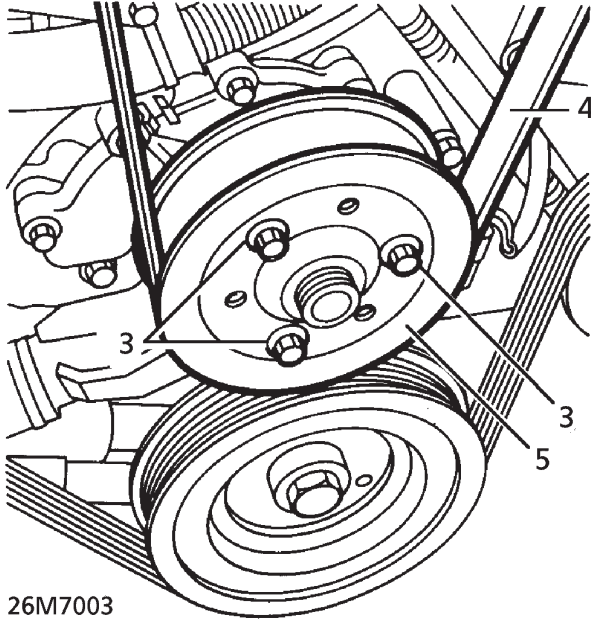

4. Release tension from water pump drive belt. Remove belt.
5. Remove water pump pulley.

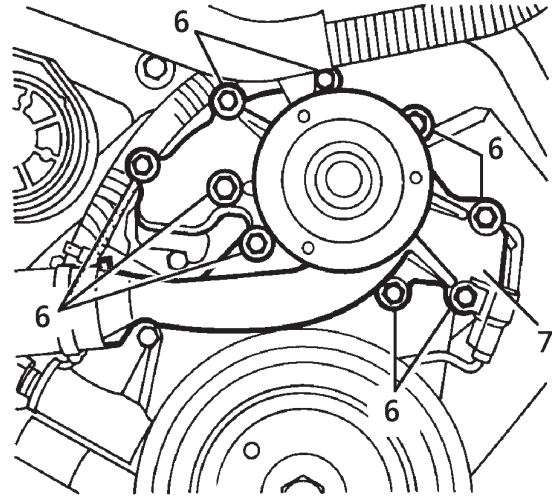

6. Remove 9 bolts securing water pump.
7. Remove water pump and gasket.

**Refit**

8. Ensure mating faces are clean.
9. Fit water pump with new gasket.
10. Position water pump. Secure with bolts. Tighten to **22 Nm (16 lbf.ft)**
11. Fit water pump pulley. Secure with bolts. Tighten to **22 Nm (16 lbf.ft)**
12. Fit water pump drive belt.
13. Fit cooling fan. *See this section.*
14. Fill cooling system. *See this section.*





---

**WATER PUMP - FROM 99MY**

---

Service repair no - 26.50.01

**Remove**

1. Drain cooling system. *See this section.*

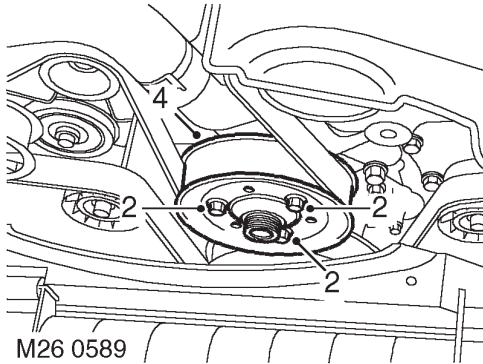

2. Loosen 3 bolts securing water pump pulley to water pump.
3. Remove auxiliary drive belt. *See ELECTRICAL, Repair.*
4. Remove 3 bolts securing pulley to water pump and remove pulley.

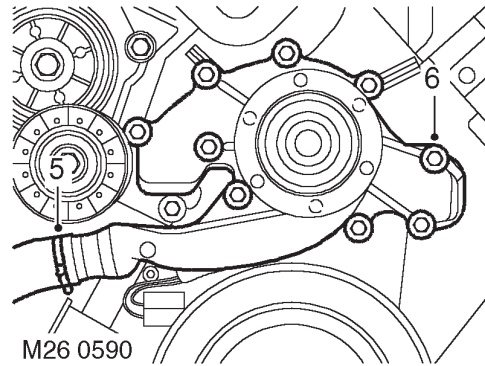

5. Release clip and disconnect coolant hose from water pump.
6. Remove 9 bolts securing water pump, remove water pump and discard gasket.

**Refit**

7. Clean water pump and mating face.
8. Fit new gasket and water pump, tighten bolts to **24 Nm (18 lbf.ft)**.
9. Connect coolant hose to water pump and secure with clip.
10. Ensure mating faces of water pump pulley and flange are clean, fit pulley and tighten bolts to **22 Nm (17 lbf.ft)**.
11. Fit auxiliary drive belt. *See ELECTRICAL, Repair.*
12. Refill cooling system. *See this section.*

**THERMOSTAT - UP TO 99MY**

Service repair no - 26.45.01

**Remove**

1. Disconnect battery earth lead.
2. Raise vehicle on 4 post ramp.
3. Remove engine acoustic cover (if applicable).  
*See CHASSIS AND BODY, Repair.*
4. Drain cooling system. *See this section.*

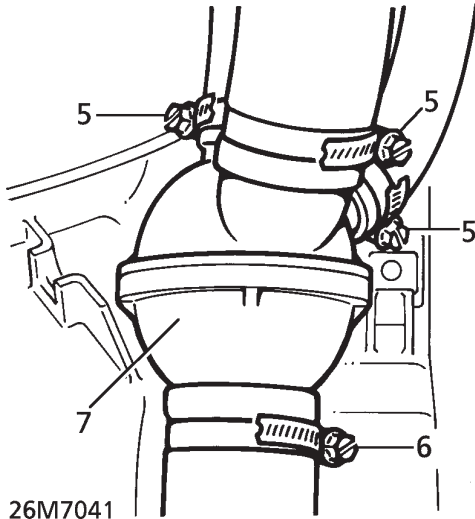

5. Loosen 3 upper hose clips and disconnect 3 hoses from top of thermostat housing.
6. Loosen lower hose clip and disconnect hose from bottom of thermostat housing.
7. Release 2 clips securing thermostat to housing radiator cowl and remove thermostat housing.

**Refit**

8. Position thermostat housing and connect to radiator hose.
9. Connect hoses to top of thermostat housing.
10. Tighten clips securing hoses to thermostat housing.
11. Engage thermostat housing to radiator cowl clips.
12. Fill coolant system. *See this section.*
13. Fit engine acoustic cover (if applicable). *See CHASSIS AND BODY, Repair.*

**THERMOSTAT - FROM 99MY**

Service repair no - 26.45.09

**Remove**

1. Drain cooling system. *See this section.*
2. Remove cooling fan. *See this section.*

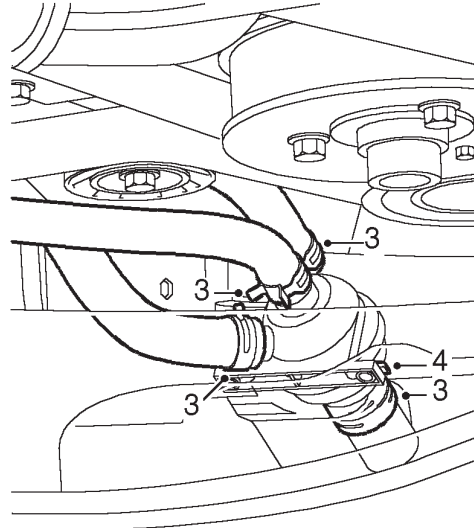

M26 0588

3. Release 3 clips and disconnect coolant hoses from thermostat.
4. Release clip securing thermostat to fan cowl and remove thermostat.

**Refit**

5. Position thermostat and secure to cowl.
6. Fit hoses to thermostat and secure with clips.
7. Fit cooling fan. *See this section.*
8. Fill cooling system. *See this section.*



---

**EXPANSION TANK**

---

Service repair no - 26.15.01



**NOTE:** This operation covers all models

**Remove**

1. Position container to collect coolant spillage.
2. Disconnect heater hose and radiator bleed hose from expansion tank.

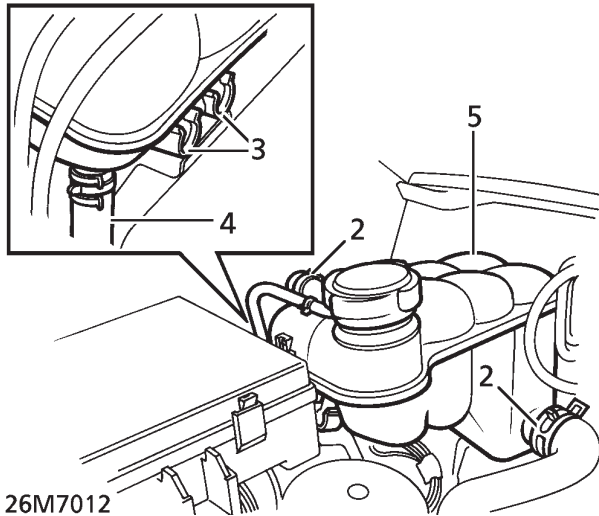

3. Release expansion tank from clips.
4. **Petrol only:** Disconnect throttle housing coolant bleed hose from expansion tank.
5. Remove expansion tank.

**Refit**

6. Reverse removal procedure.
7. Check and top up cooling system.