

JLRTB02058NAS1
TECHNICAL BULLETIN
19 AUG 2021



© Jaguar Land Rover North America, LLC

NOTE: The information in Technical Bulletins is intended for use by trained, professional Technicians with the knowledge, tools, and equipment required to do the job properly and safely. It informs these Technicians of conditions that may occur on some vehicles, or provides information that could assist in proper vehicle service. The procedures should not be performed by 'do-it-yourselfers'. If you are not a Retailer, do not assume that a condition described affects your vehicle. Contact an authorized Land Rover service facility to determine whether this bulletin applies to a specific vehicle.

SECTION:

501-08

SUBJECT/CONCERN:

Tapping Noise From A-Pillar Area

MARKETS:

NORTH AMERICA

CONDITION SUMMARY:

SITUATION:

When traveling at speeds over 60 km/h (37 mph) a constant low-level tapping noise can be heard coming from the A-pillar area, on one or both sides of the vehicle. In some cases, further investigation may have found that the windshield molding may have become loose.

CAUSE:

Insufficient windshield molding clip tension.

ACTION:

Follow the instructions below.

PARTS:**NOTES:**

- Do not order a new 'repair kit' for each repair. Each 'repair kit' contains enough 3M™ adhesive tape - ST 1200, 3M™ surface cleaner wipes and 3M™ Adhesion Promoter 06396 to repair approximately 10 repairs. If additional 3M™ DP8810NS adhesive is required, order LR159365 in the part list below, as required.
- 1 sachet of 3M™ Adhesion Promoter 06396 can be used for 2 windshield moldings, when applied at the same time.
- 1 sachet of 3M™ surface cleaner will clean the surface of 2 windshield moldings.
- 2 10 mm x 620 mm strips of 3M™ adhesive tape - ST 1200 are required per vehicle.
- *A total allowance equivalent to \$1.40 **per repair** has been allocated to locally source the parts listed below for '**vehicles without raise air intakes**'.
- **A total allowance equivalent to \$1.70 **per repair** has been allocated to locally source the parts listed below for '**vehicles with raise air intakes**'.
- ***A total allowance equivalent to \$8.40 **per repair** has been allocated to locally source the parts listed below for '**vehicles without raise air intake - Within Vehicle Identification Number (VIN) range 001508 to 017609**'.
- ****A total allowance equivalent to \$8.70 **per repair** has been allocated to locally source the parts listed below for '**vehicles with raise air intake - Within VIN range 001508 to 017609**'.

PART NUMBER	DESCRIPTION	QUANTITY
Vehicles without raised air intake		
*ZZZ001	Felt tape - 2mm thick	\$1.40

PART NUMBER	DESCRIPTION	QUANTITY
LR159363	Repair kit	1
Vehicles with raised air intake		
LR131675	Door hinge bolts	2
**ZZZ001	Felt tape - 2mm thick	\$1.40
**ZZZ001	3M™ double sided adhesive tape - PT 1100 (or equivalent)	\$0.30
LR159363	Repair kit	1
Vehicles without raised air intake - Within VIN range 001508 to 017609		
***ZZZ001	Felt tape - 2mm thick	\$1.40
***ZZZ001	3M™ EPX applicator - DS272990500	\$7.00
LR159364	Repair kit - Including adhesive and nozzle	1
Vehicles with raised air intake - Within VIN range 001508 to 017609		
LR131675	Door hinge bolts	2
****ZZZ001	Felt tape - 2mm thick	\$1.40
****ZZZ001	3M™ EPX applicator - DS272990500	\$7.00
****ZZZ001	3M™ double sided adhesive tape - PT 1100 (or equivalent)	\$0.30
LR159364	Repair kit - Including adhesive and nozzle	1
Additional Adhesive		
LR159365	3M™ DP8810NS (45ml) cartridge and nozzle	1

WARRANTY:

NOTE:

* When submitting your Warranty claim within the Warranty portal, use the Condition Code list shown to select the Condition Code which best describes the vehicle defect.

NOTES:

- Repair procedures are under constant review, and therefore times are subject to change; those quoted here must be taken as guidance only. Use TOPIx to obtain the latest repair time.
- The JLR claims submission system requires the use of causal part numbers. Labor only claims must show the causal part number with a quantity of zero.

DESCRIPTION	SRO	TIME (HOURS)	CONDITION CODE	CAUSAL PART
JLRTB02058 - Windshield Molding - Modification - Both sides - Without raised air intake	99.01.31	0.3	*	LR131995
JLRTB02058 - Windshield Molding - Modification - Both sides - With raised air intake	99.01.36	0.4	*	LR131995
JLRTB02058 - Windshield Molding - Modification - Both sides - Vehicles without raised air intake - Within VIN range 001508 to 017609	99.01.37	0.5	*	LR131995
JLRTB02058 - Windshield Molding - Modification - Both sides - Vehicles with raised air intake - Within VIN range 001508 to 017609	99.01.38	0.6	*	LR131995

NOTE:

Normal Warranty procedures apply.

SERVICE INSTRUCTION:

CAUTION:

Always protect the paintwork and windows when removing exterior components.

NOTES:

- Some variation in the illustrations may occur, but the essential information is always correct.
- Some components are shown removed for clarity.

All vehicles

1.

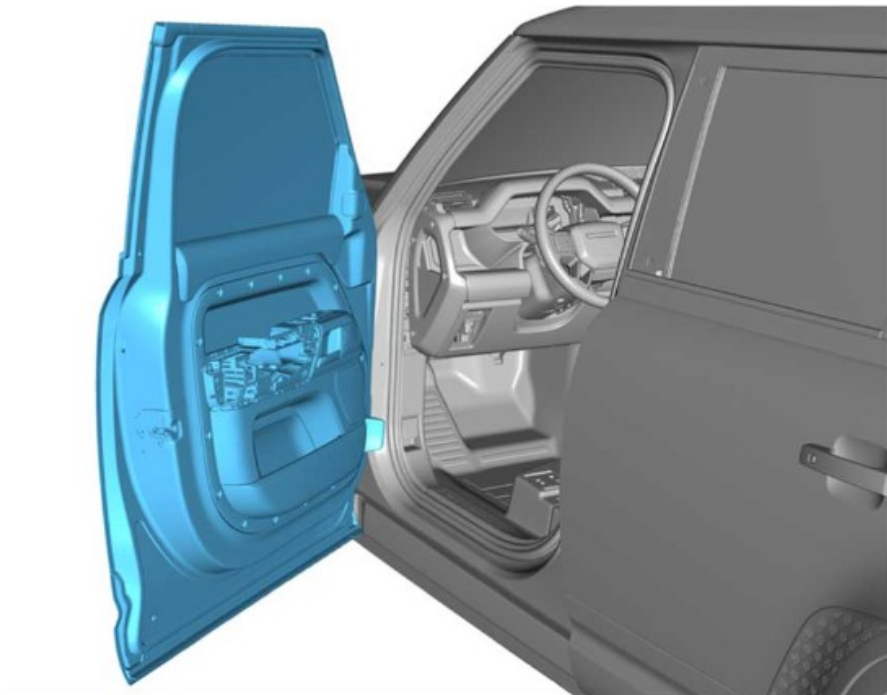

E270909

Open the front left door.

Vehicles installed with raised air intakes only**NOTE:**

Raised air intakes are only installed on the left side of the vehicle. Do not complete steps 2 to 9 for the right side of the vehicle.

-
2. Disconnect the startup battery ground cable (see TOPIx Workshop Manual section 414-00: Battery and Charging System - General Information - General Procedures - Startup Battery Disconnect and Connect).
-

3.

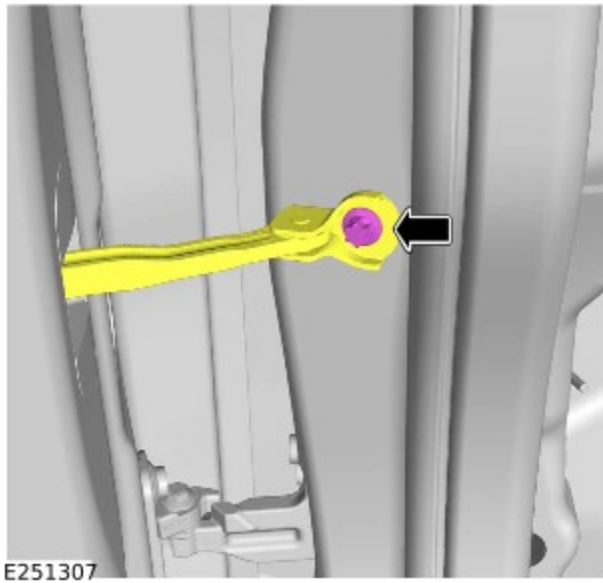

Disconnect the front door check arm.

- Remove the bolt.

4.

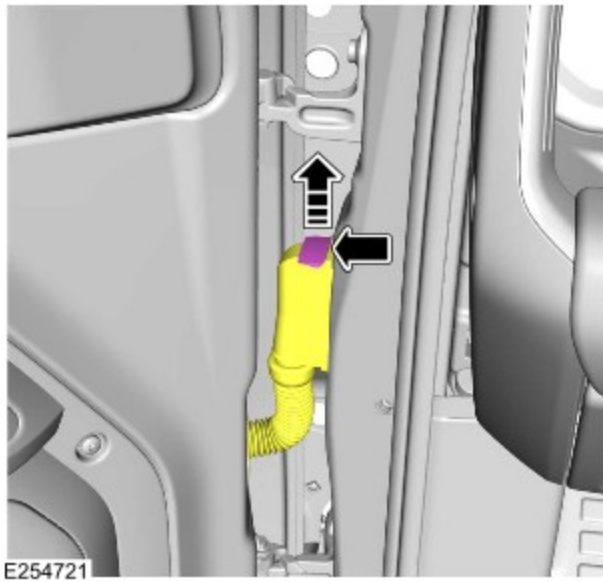

Disconnect the front door wiring harness from the body wiring harness.

5.

CAUTIONS:

- Lay the front door on felt covered supports.
- The component may be heavy. Take extra care when handling.

NOTE:

This step requires the assistance of another technician.

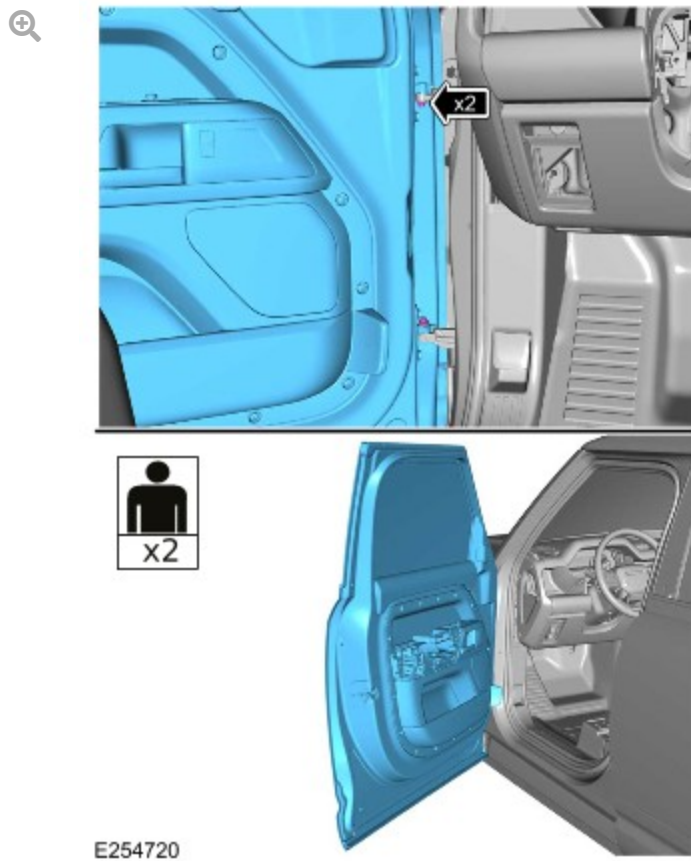

Remove the front left door.

- Remove and discard the 2 bolts.

6.

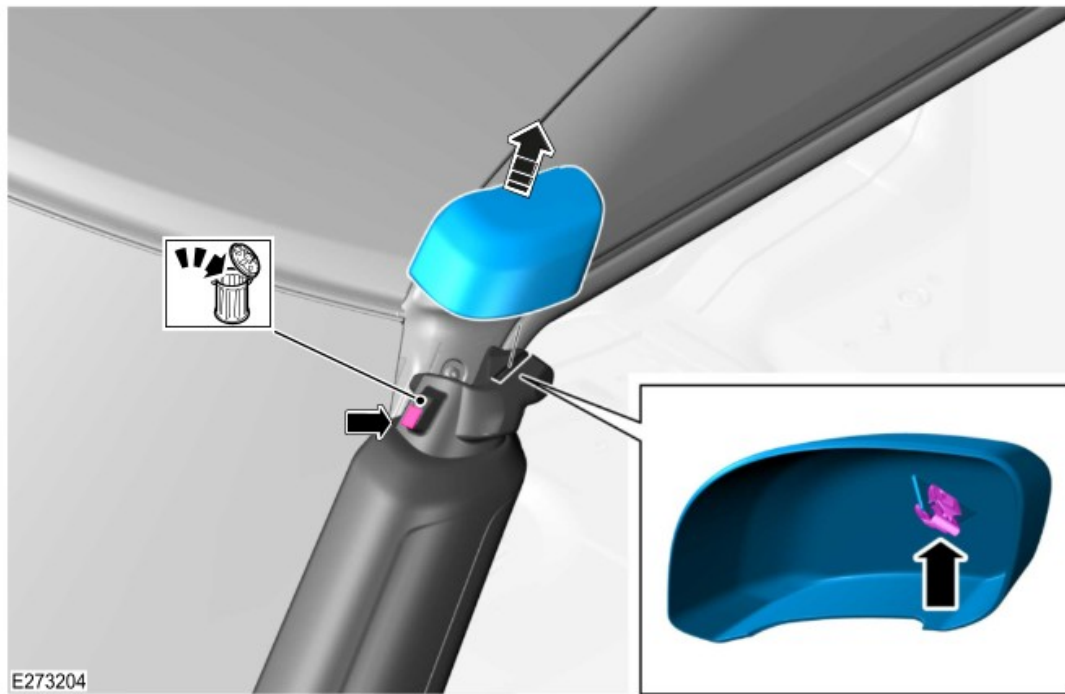

Remove the cover.

- Release the clip.
- Remove and discard the double sided tape.

7.

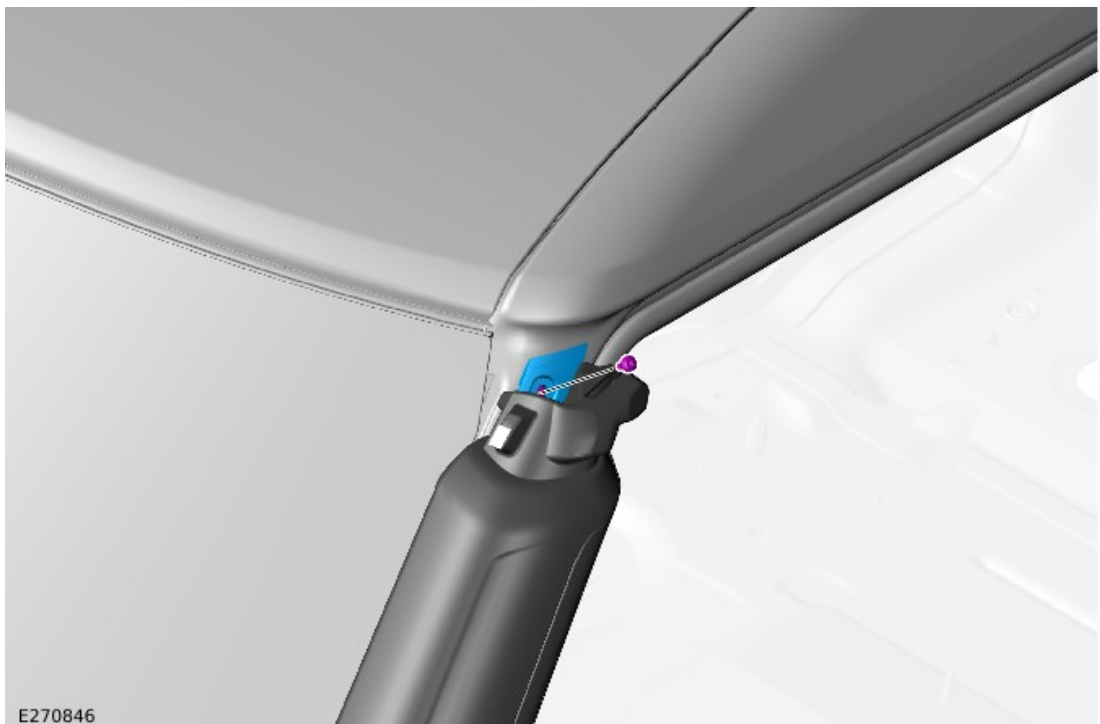

Remove the bolt.

8.

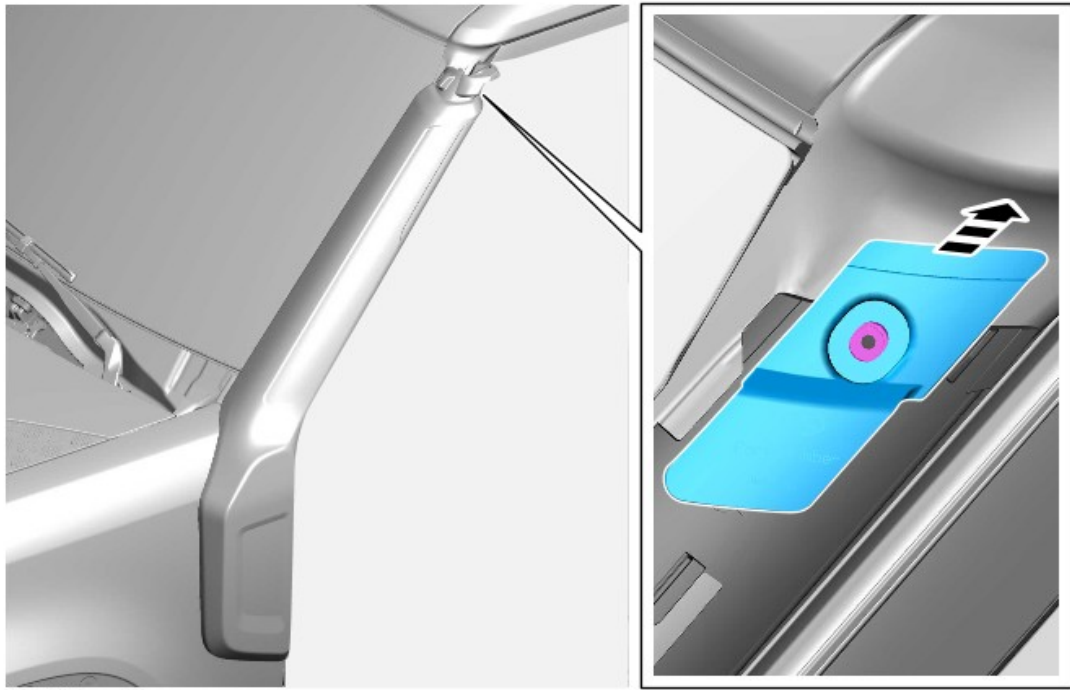

E270850

Remove the bracket.

9.

CAUTION:

Protect the gap between the body and the fender to prevent fixings from dropping into the void.

NOTE:

This step requires the assistance of another technician.

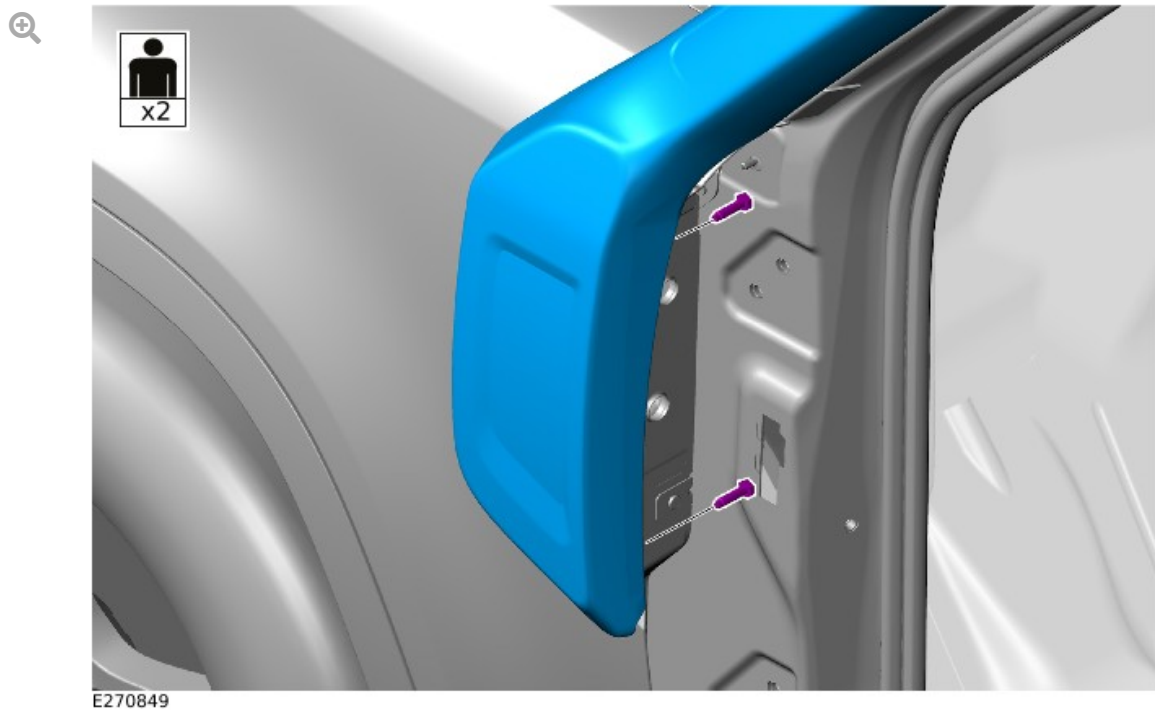

Remove the raised air intake.

- Remove the 2 bolts.

All vehicles

10.



0:00

This video shows a demonstration of how to remove the windshield molding bolt cover.

11.

CAUTION:

Extra care must be taken not to damage the windshield molding bolt cover.

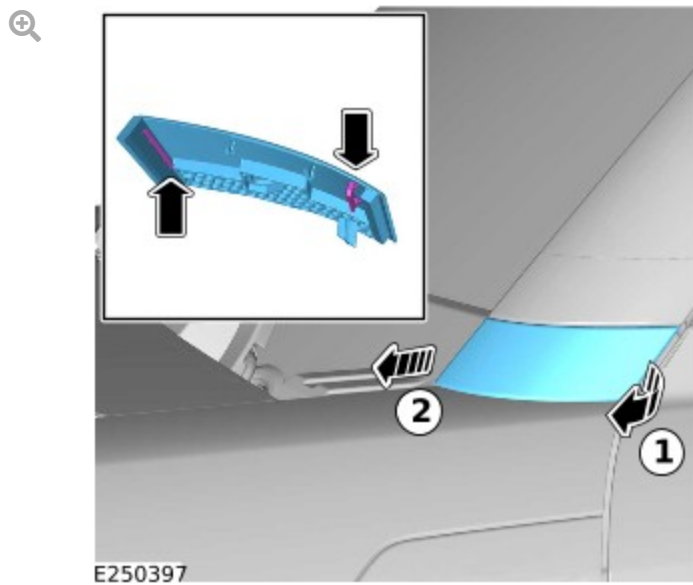

Release the 2 clips to remove the left windshield molding bolt cover.

1. Release the clip closest to the door first, in the direct shown in the illustration.
2. Release the second clip by pulling the bolt cover away from the vehicle in a forward direction.

12.

CAUTIONS:

- Extra care must be taken not to damage the windshield molding.
- Do not use tools during this operation, removal of the component must be completed by hand.

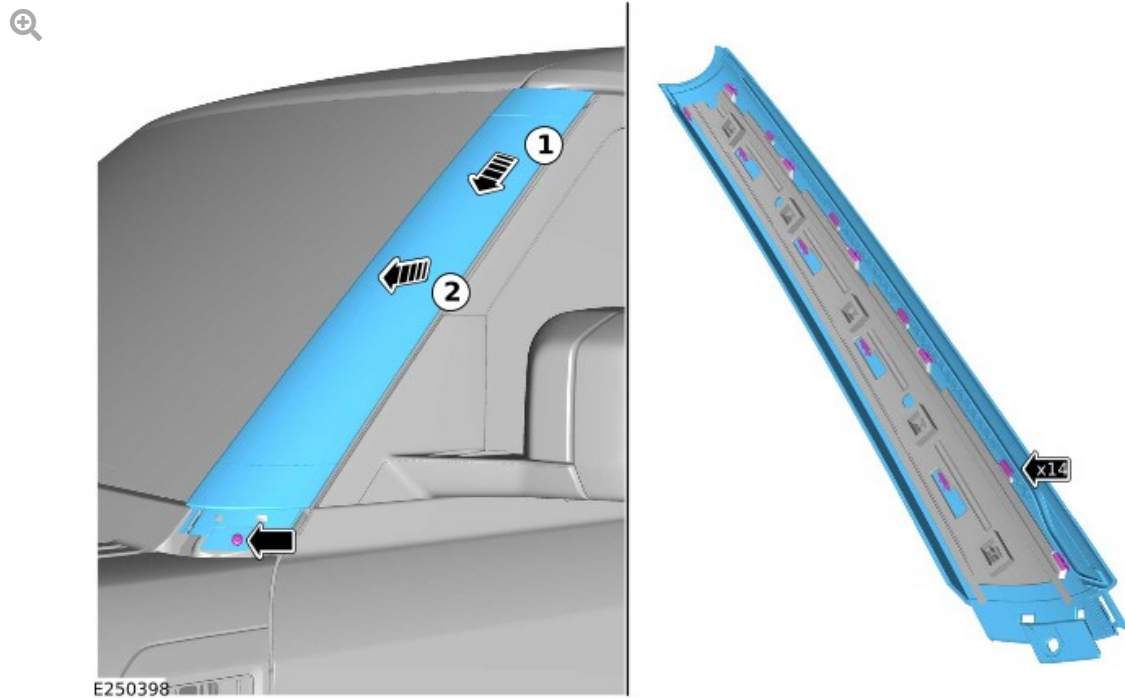

Remove the retaining bolt and then remove the left windshield molding.

1. Pull the windshield molding down in the direction shown in the illustration.
2. Release the windshield molding from the vehicle by pulling in a forward direction.

13.

NOTE:

The windshield molding carrier is secured to the body using 2 strips of double sided tape, 5 clips and polyurethane adhesive.

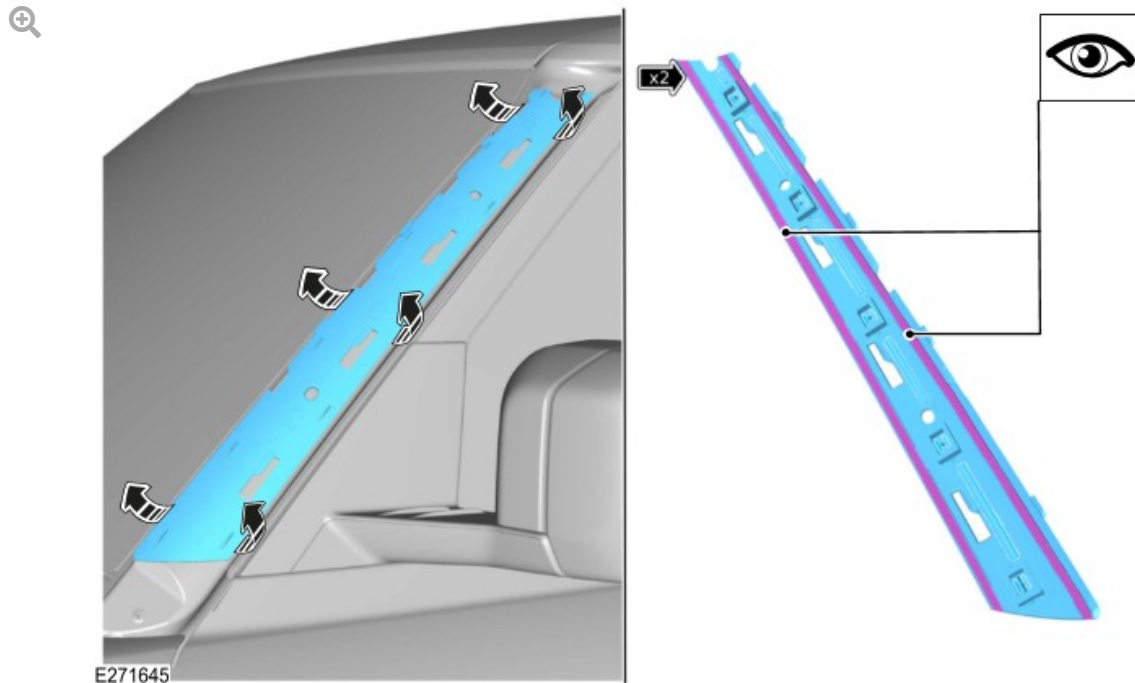

Check that the 2 strips of double sided tape are fully adhered to the body.

- By hand, pull along both edges of the windshield molding carrier while visually inspecting the tape for adhesion.
 - If both strips of double sided tape **are** fully adhered to the body, **continue to step 14.**
 - If any of the strips of double sided tape **are not** fully adhered to the body, **renew the windshield molding carrier as part of a separate warranty claim (see TOPIx Workshop Manual section 501-11: Glass, Frames and Mechanisms - Removal and Installation - Windshield Molding Carrier).**

14.

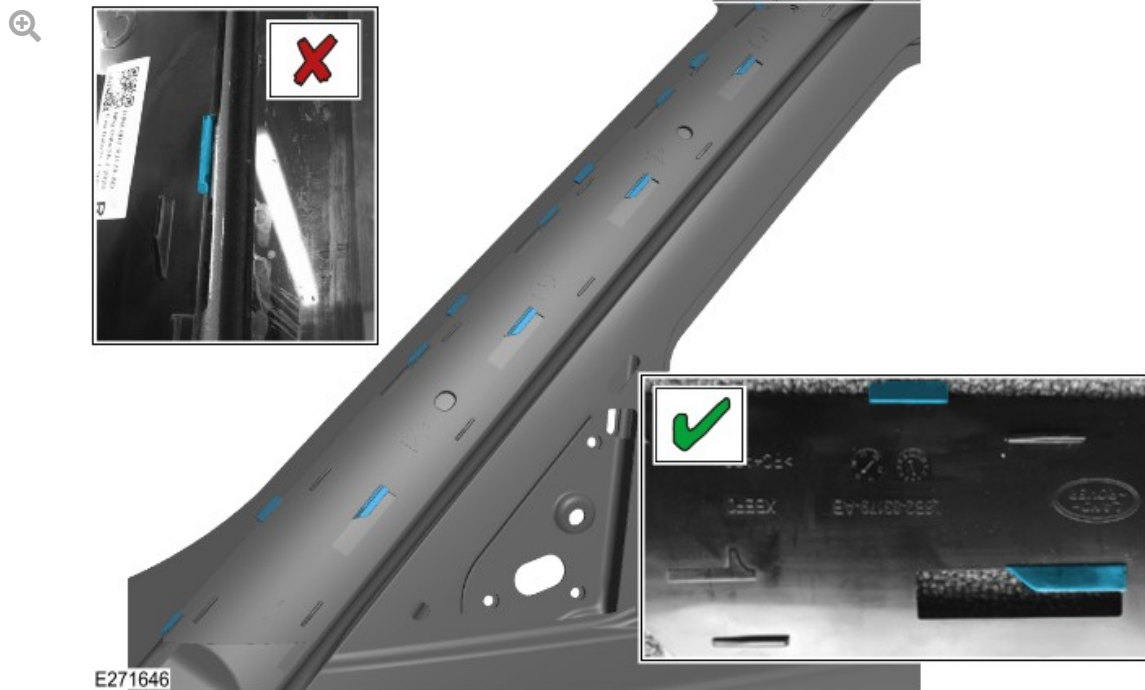

Visually inspect the windshield molding carrier for damage to the clipping features shown in the illustration.

- If the clipping features **are not** damaged, as shown in the image with a **GREEN '√'**, **continue to step 15.**
- If any of the clipping features **are** damaged, as shown in the image with a **RED 'X'**, **renew the windshield molding carrier as part of a separate warranty claim (see TOPIx Workshop Manual section 501-11: Glass, Frames and Mechanisms - Removal and Installation - Windshield Molding Carrier).**

Vehicles inside VIN range 001508 to 017609 only

NOTE:

1 adhesive cartridge contains enough adhesive to repair both windshield moldings on 1 vehicle.

15.

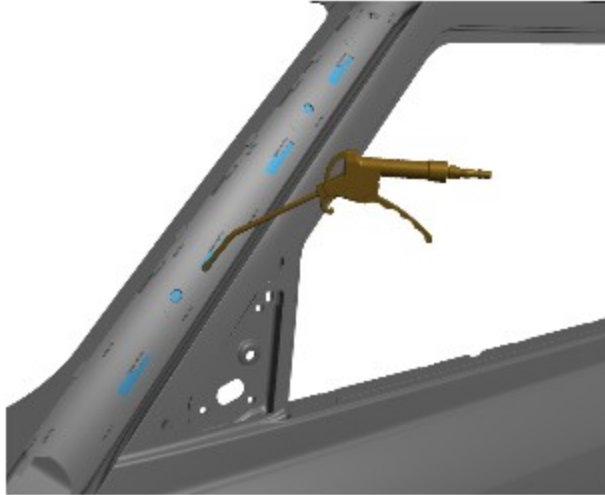

E271648

Using a suitable tool, blow compressed air into the holes shown highlighted in the illustration. This will remove any loose debris and contaminants.

16. Prepare the adhesive following the manufacturer's instructions.

17.





0:00



This video shows a demonstration of how to apply the adhesive in the locations shown in steps 18 and 19.

18.

CAUTIONS:

- Do not apply adhesive to the upper section of the slotted holes, where the windshield molding locates, as it will obstruct the installation of the windshield molding.
- Do not apply too much sealant as the excess will obstruct the installation of the windshield molding.

NOTE:

Remove any excess adhesive before the adhesive cures.



E273200

Using the recommended adhesive and applicator, apply the adhesive in the bottom of the slotted holes.

19.

CAUTION:

Do not apply too much sealant as the excess will obstruct the installation of the windshield molding.

NOTE:

Remove any excess adhesive before the adhesive cures.



E273201

Using the recommended adhesive and applicator, apply the adhesive into the top and bottom of the round holes.

-
20. Allow the adhesive to cure, as per the manufacturer's instructions, before continuing to the next step.

All vehicles

21.



Locate the windshield molding carrier part number.

- If the part number is **L8B2-03178-AB**, **L8B2-03179-AB**, **L8B2-03178-AC** or **L8B2-03179-AC**, continue to **step 22**.
- If the part number is **L8B2-03178-AD** or **L8B2-03179-AD**, continue to **step 23**.

22.

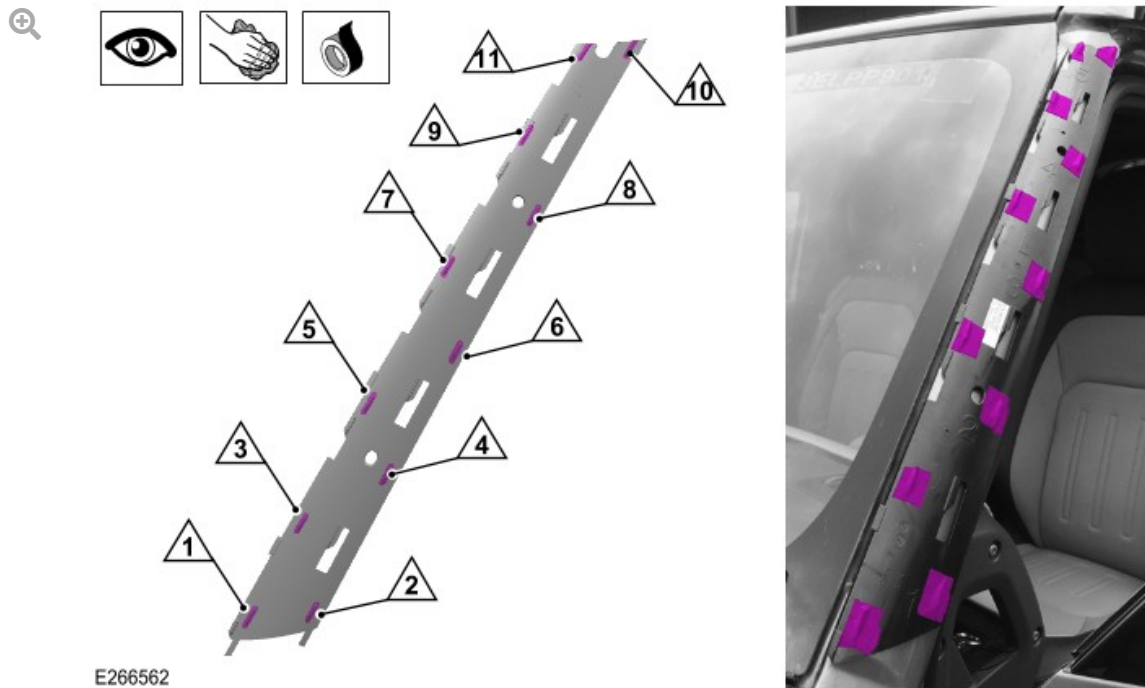

Locate the 11 windshield molding retaining ribs, as shown highlighted in the illustration.

- Clean the area around each windshield molding retaining rib.
- Apply felt tape to cover each of the 11 windshield molding retaining ribs, as shown in the illustration.

23.

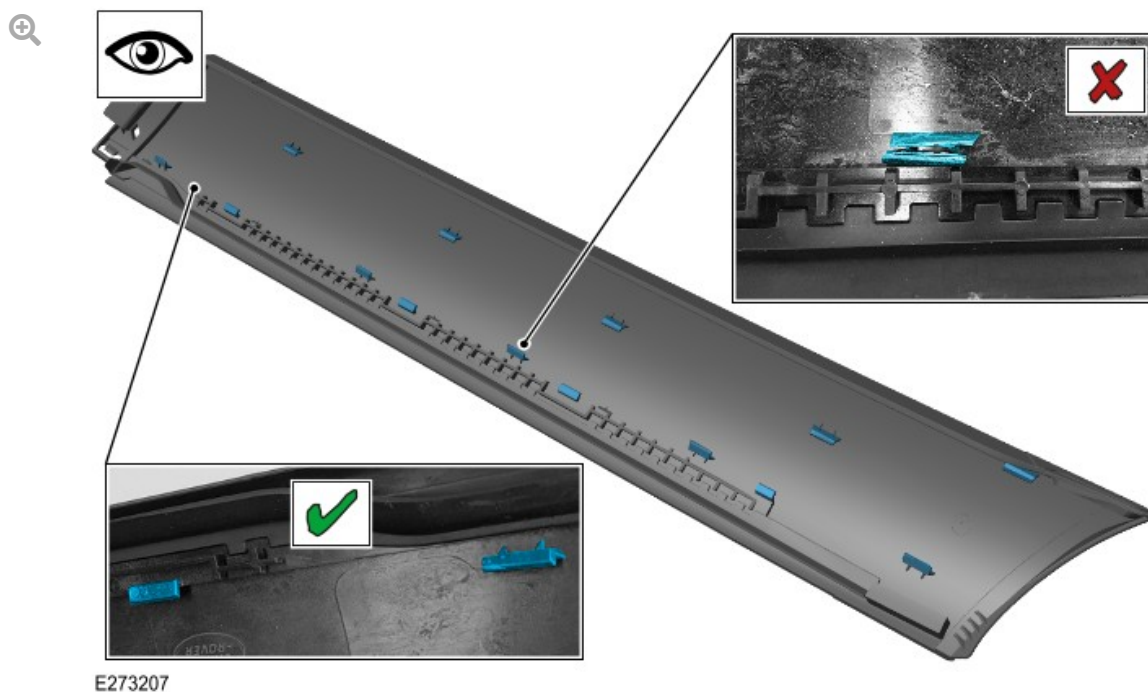

Inspect the windshield molding for damaged clipping features.

- If the clipping features **are not** damaged, as shown in the image with a **GREEN '✓'**, **continue to step 24.**
- If any of the clipping features **are** damaged, as shown in the image with a **RED 'X'**, **a new windshield molding must be ordered and claimed as part of a separate warranty claim before continuing to step 24.**

24.

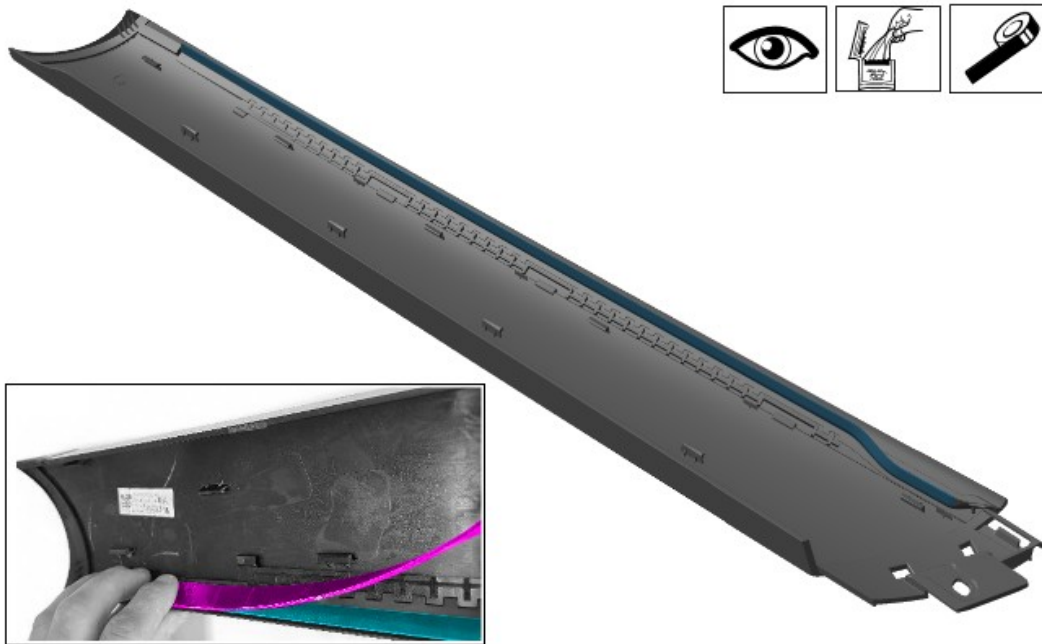

E271647

Inspect the rubber seal on the windshield molding for damage. If the seal is damaged a new windshield molding is required before continuing with this step, this must be claimed as a separate warranty claim.

- **NOTE:**
Allow a minimum of 60 seconds for the 3M™ surface cleaner to dry before continuing.

Using 3M™ surface cleaner, clean the inside edge of the rubber seal, as shown highlighted in the illustration.

- **NOTE:**
Allow a minimum of 90 seconds for the 3M™ adhesion promoter to dry before continuing.

Following the manufacturer's specifications, apply the 3M™ adhesion promoter to the inside edge rubber seal, as shown highlighted in the illustration.

- Cut a length of 3M adhesive tape - ST 1200 to the following dimensions:
 - **10 mm x 620 mm**

- NOTE:**
 Make sure the 3M adhesive tape is aligned with the edge of the rubber seal.

Gradually remove the adhesive backing and install the 3M adhesive tape - ST 1200 (or equivalent) in small sections at a time. Apply firm pressure along the entire length of the rubber seal to make sure the adhesive is bonded.

25.

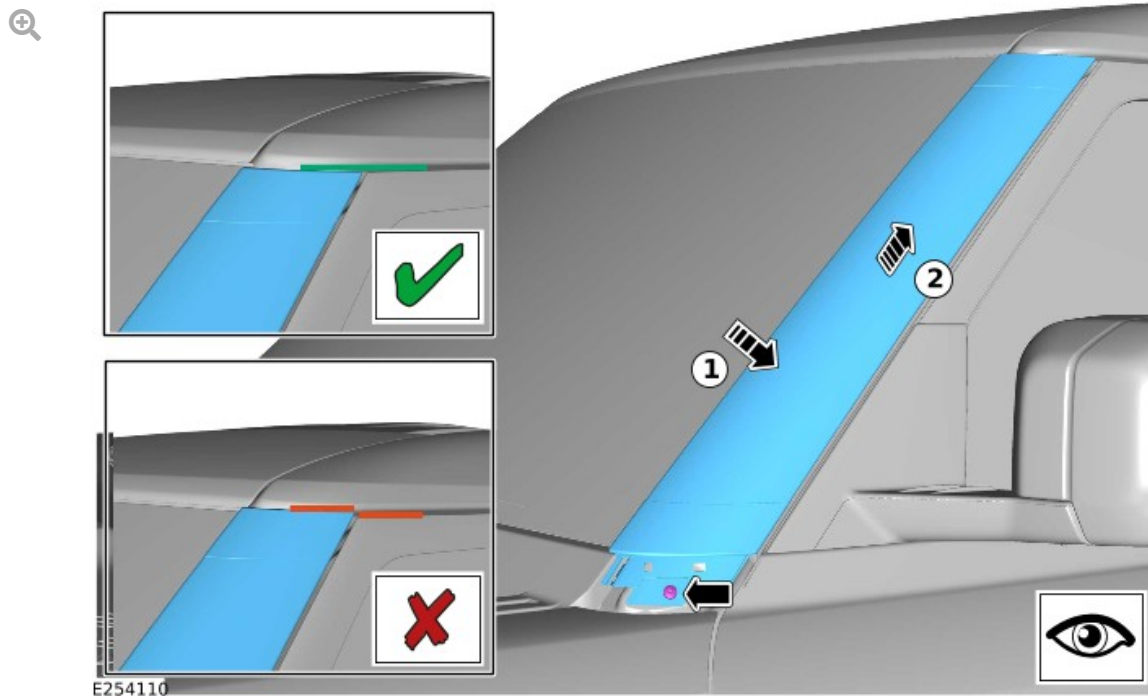

Install the windshield molding in the directions shown in the illustration.

- NOTE:**
 Make sure all of the clips are correctly located and fully engaged.

Do not fully tighten the retaining bolt at this stage.

26.



E273208

Make sure all of the windshield molding clips are correctly located by rotating the windshield molding in the directions shown in the illustration.

- If excessive movement and/or an excessive gap between the windshield molding and the windshield **is** evident, **remove the windshield molding and repeat step 25.**
- If excessive movement and/or an excessive gap between the windshield molding and the windshield **is not** evident, **continue to step 27.**

27.



Apply downward pressure onto the windshield molding and fully tighten the retaining bolt.

- Torque: **6 Nm**

28.

NOTE:

If a new windshield molding bolt cover is required, it must be painted before installing.



E266564

Inspect the retaining clip on the windshield molding bolt cover.

- If the retaining clip is broken, as shown highlighted in the illustration, **install a new windshield molding bolt cover during the next step and claim it as part of a separate warranty claim.**
- If the retaining clip is **not** broken, **install the original windshield molding bolt cover during the next step.**

29.



0:00

This video shows a demonstration of how to install the windshield molding bolt cover.

30.

NOTES:

- When installing the windshield molding bolt cover make sure an audible click is heard.
- When installing the windshield molding bolt cover make sure it is flush with the windshield molding.

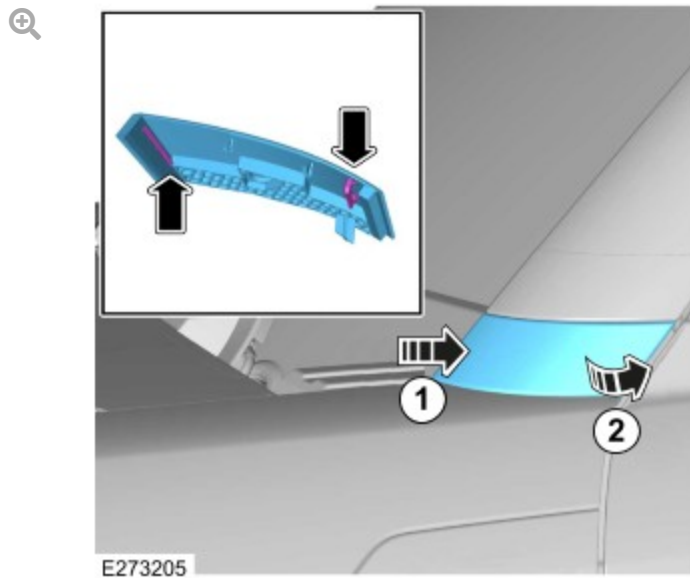

Install the windshield molding bolt cover.

1. Secure the clip closest to the windshield first, in the direct shown in the illustration.
2. Secure the second clip in the direction shown in the illustration..

Vehicles installed with raised air intakes only

31.

CAUTION:

Protect the gap between the body and the fender to prevent fixings from dropping into the void.

NOTE:

This step requires the assistance of another technician.

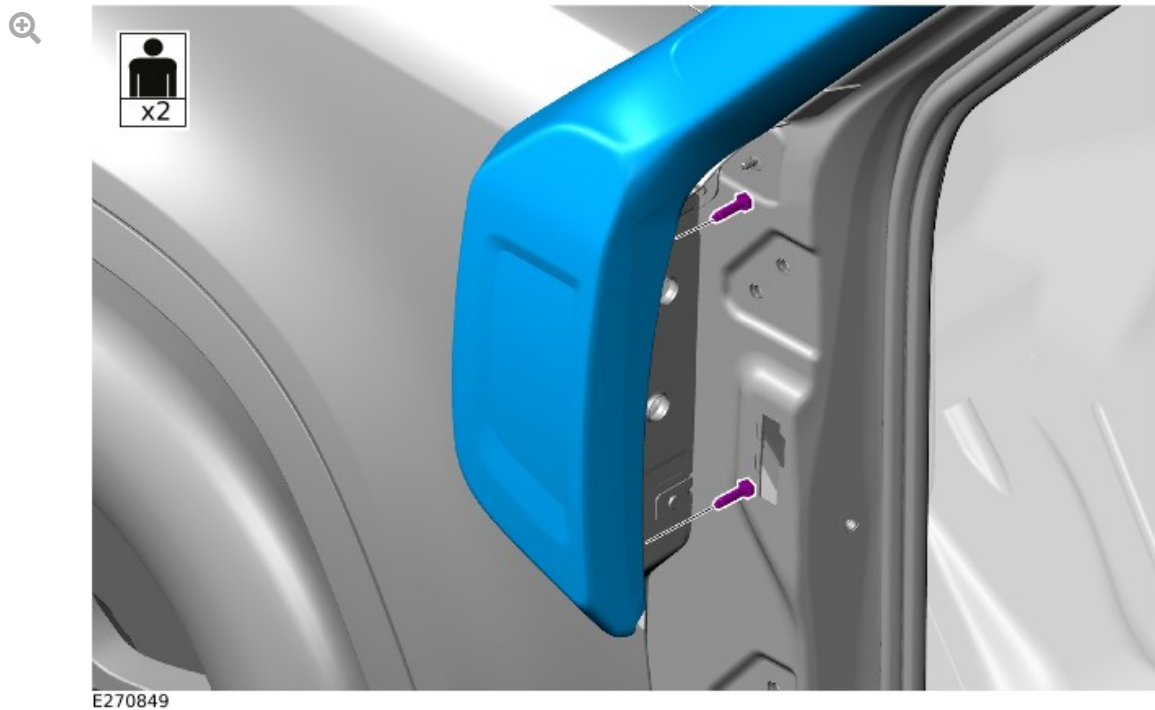

Install the raised air intake.

- Install the 2 bolts but do not fully tighten.

32.

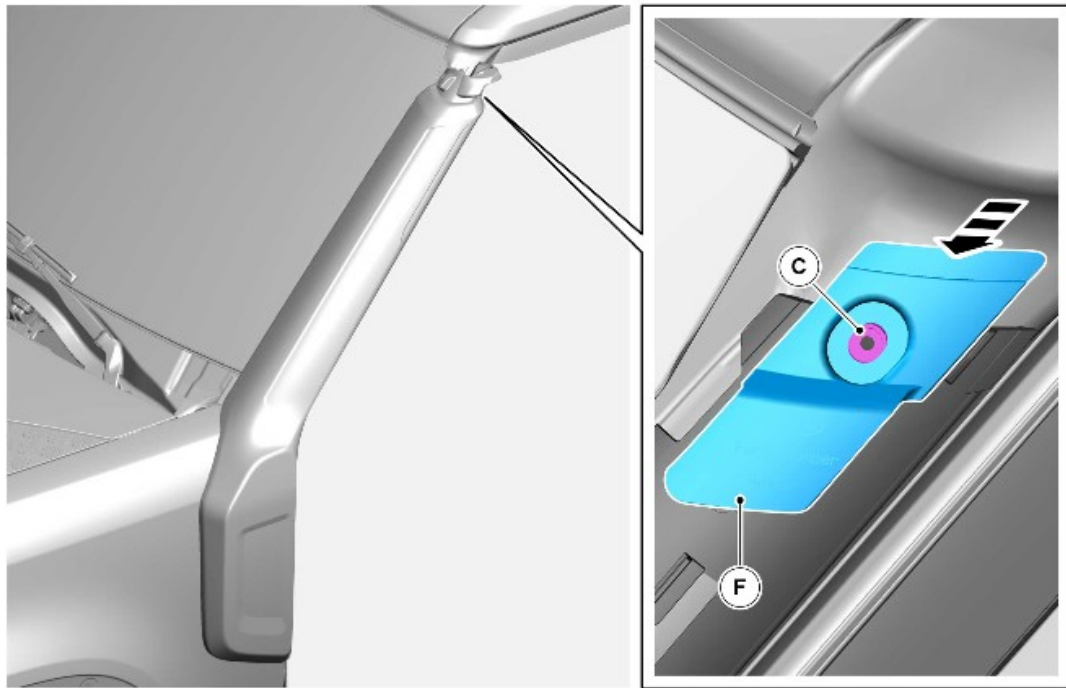

Install the bracket (F) into the slot in the raised air intake.

- Make sure the hole in the bracket (F) aligns with the fixing (C).

33.

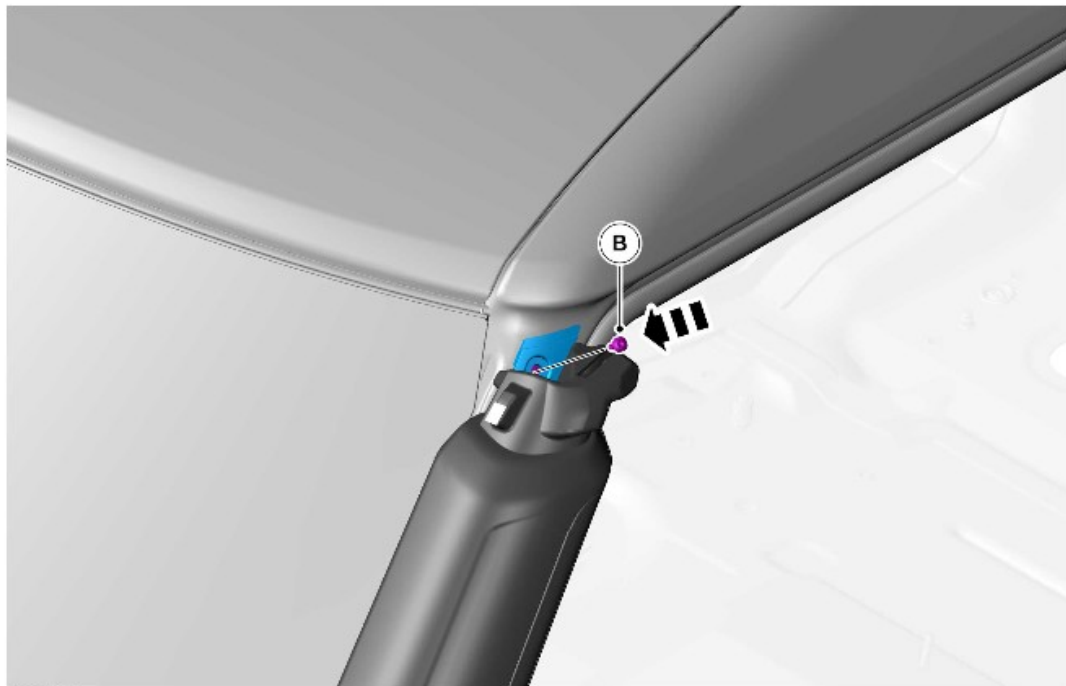

Install the bolt (B) through the bracket and into the fixing.

- Torque: **4 Nm**

34. Fully tighten the 2 bolts from **step 31**.

- Torque: **3 Nm**

35.

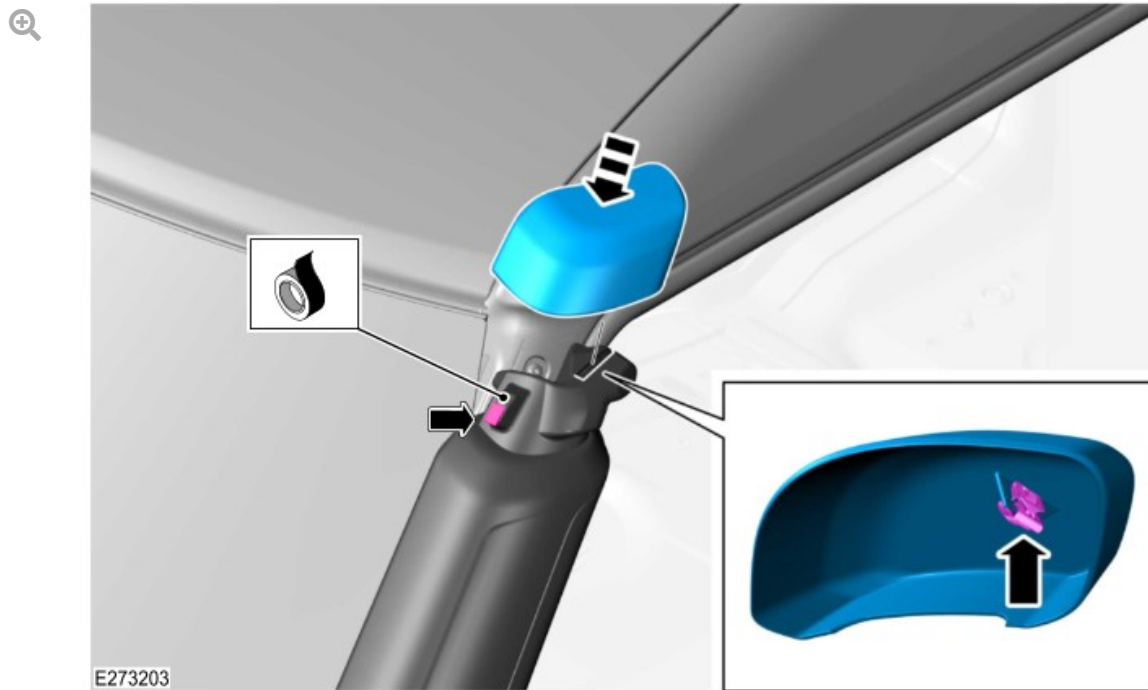

Install the cover.

- Install a new piece of 3M PT 1100 (or equivalent) double sided tape (9 mm x 15 mm).
- Secure the clip.

36.

CAUTION:

The component may be heavy. Take extra care when handling.

NOTE:

This step requires the assistance of another technician.

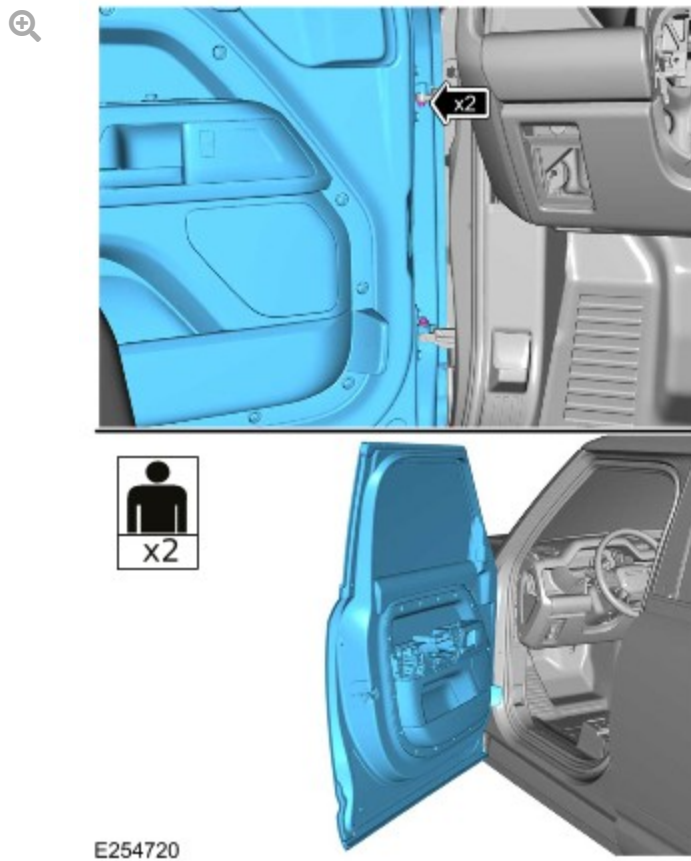

Install the front left door.

- Install and tighten the 2 new bolts.
 - Torque: **30 Nm**

37.

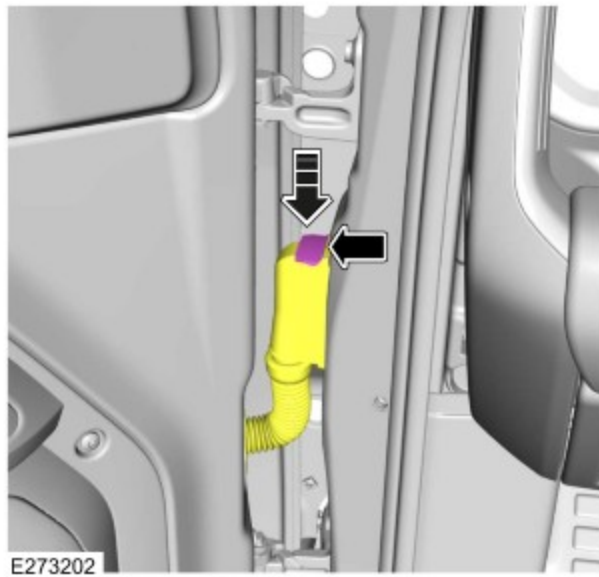

Connect the front door wiring harness from the body wiring harness.

38.

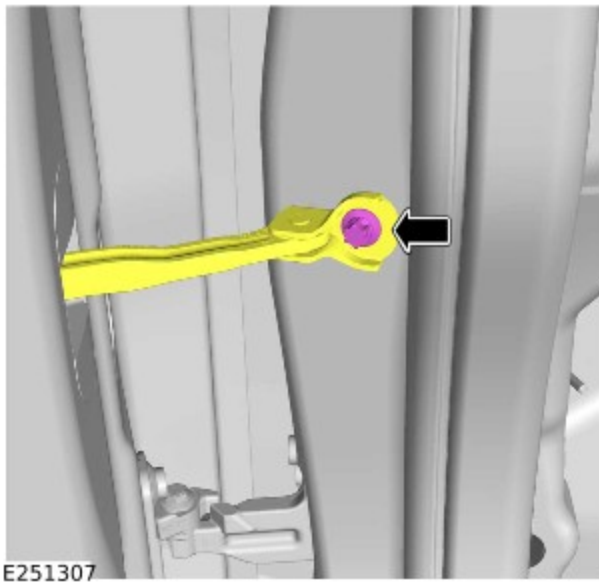

Connect the front door check arm.

- Install and tighten the bolt.
- Torque: **25 Nm**

All vehicles

39.

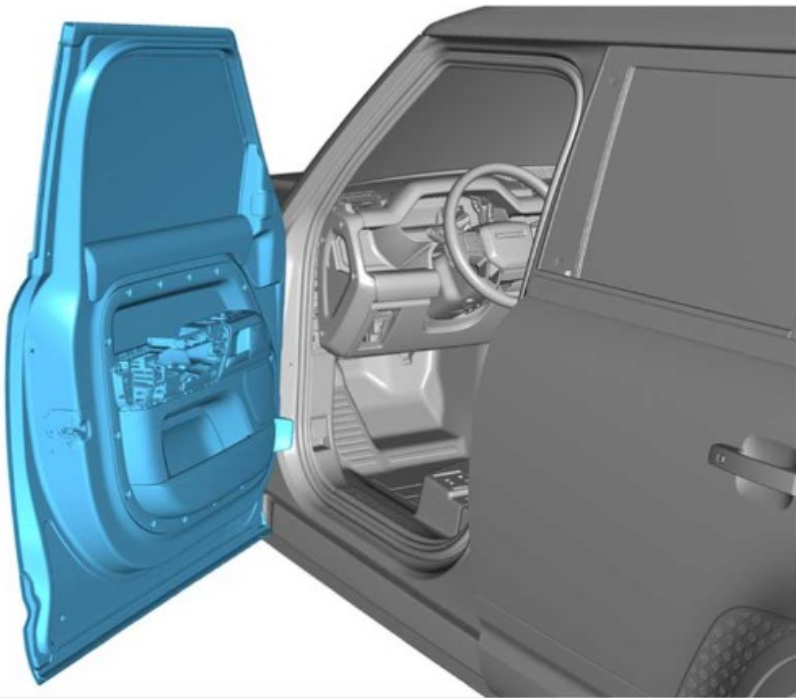

E270909

Close the front left door.

-
40. Repeat steps 1 to 39 for the other side.
-
41. Connect the startup battery ground cable (see TOPIx Workshop Manual section 414-00: Battery and Charging System - General Information - General Procedures - Startup Battery Disconnect and Connect).

dWJvbmZhbRiOziwMjEEMDkxMjBUMDQGMjc6MTcuOTESWjs0Ny4yOC43NC4yMDg7U0FH9Rtk3RVU0TDIwMTI0Mjc=