

PUBLISHED: 30-JUL-2019  
2020.0 DEFENDER (LE), 204-04

WHEELS AND TIRES

# TIRE PRESSURE MONITORING SYSTEM (G2341725)

## COMPONENT LOCATION

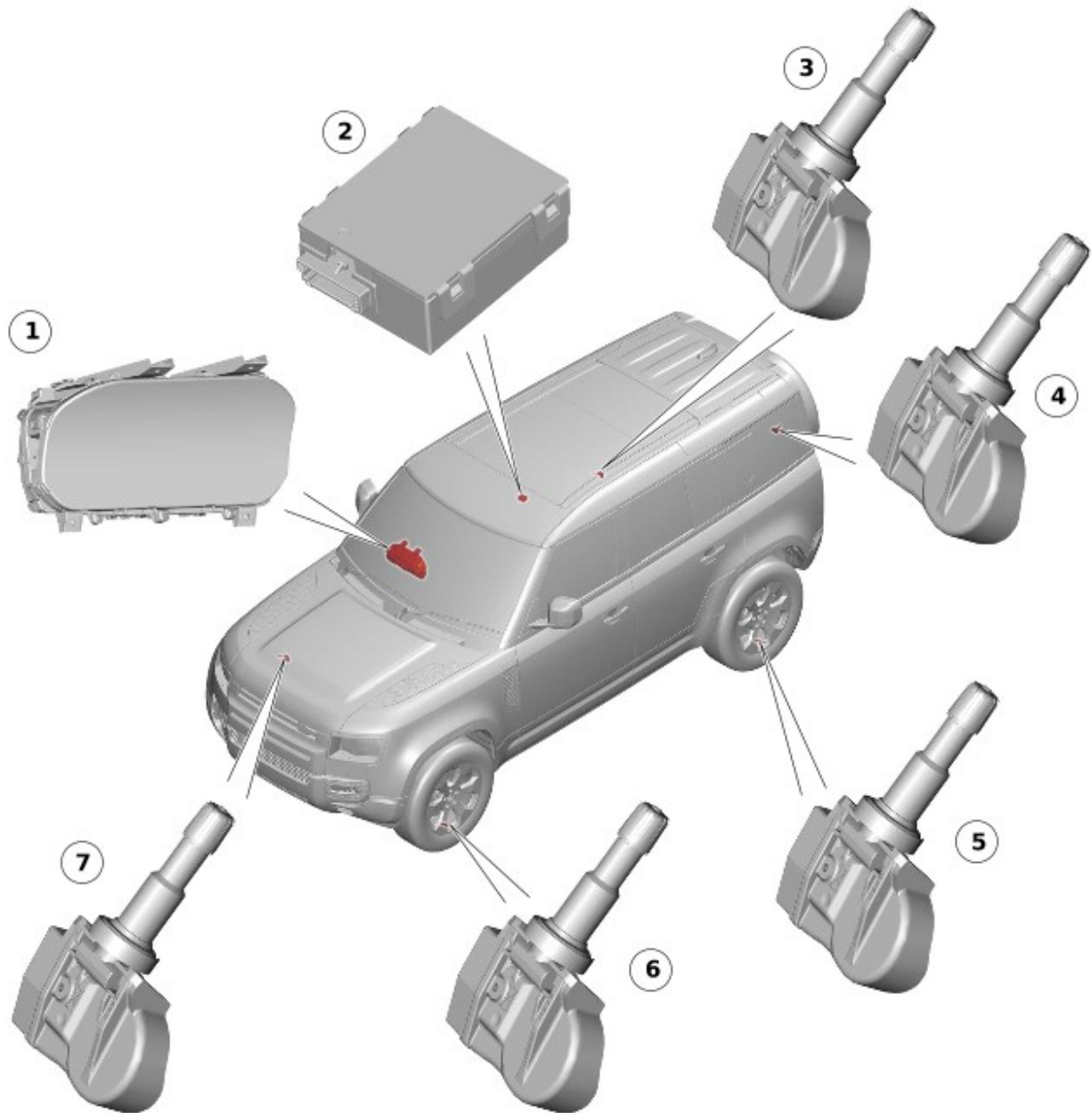

E250043

ITEM	DESCRIPTION
1	Instrument Cluster (IC)
2	Tire Pressure Monitoring System Control Module (TPMSCM)
3	Tire pressure sensor - Rear right wheel

ITEM	DESCRIPTION
4	Tire pressure sensor - Spare wheel
5	Tire pressure sensor - Rear left wheel
6	Tire pressure sensor - Front left wheel
7	Tire pressure sensor - Front right wheel

## OVERVIEW

### TIRE PRESSURE MONITORING SYSTEM

#### NOTES:

- During a tire 'blow out' a very rapid reduction in pressure is experienced. The Tire Pressure Monitoring System (TPMS) is not intended to warn the driver of a 'blow out'. It is not possible to give the driver sufficient warning that such an event is occurring, due to its short duration. The TPMS assists the driver to keep the tires at correct pressure. The TPMS tends to reduce the likelihood of a tire 'blow out' occurring.
- The Tire Pressure Monitoring System (TPMS) is inhibited when the vehicle is in Transit mode. For more details on Transit mode refer to the Pre-Delivery Inspection (PDI) manual.

The Tire Pressure Monitoring System (TPMS) measures the pressure in each of the tires on the vehicle. The TPMS issues warnings to the driver if any of the pressures deviate from those defined by local legislation.

A single TPMS hardware configuration is used. The TPMS status information is relayed to the driver with a message displayed in the Instrument Cluster (IC) message center and an amber warning indicator.

The purpose of the TPMS is to assist the driver in maintaining the vehicle's tire pressures at the optimum level in order to:

- Improve fuel consumption.
- Maintain ride and handling characteristics.
- Reduce the risk of rapid tire deflation, which may be caused by under inflated tires.
- Comply with legislation in relevant markets.

### TRANSPORT RECALL ENHANCEMENT, ACCOUNTABILITY AND DOCUMENTATION ACT – NORTH AMERICAN SPECIFICATION VEHICLES ONLY

#### NOTES:

- If tires and wheels of a non-standard size are installed to the vehicle, the Car Configuration File (CCF) must be updated. The CCF must be updated using the Jaguar Land Rover (JLR) approved diagnostic equipment.

- If the label is damaged or removed for body repair, it must be replaced with a new label specific to that vehicle. A new label is requested from Jaguar Land Rover parts and will be printed specifically for the supplied Vehicle Identification Number (VIN) of the vehicle.

Vehicles supplied to the North American Specification (NAS) markets must comply with the legislation of the Transport Recall Enhancement, Accountability and Documentation (TREAD) act. Part of the requirement of the TREAD act is for the vehicle to display a label, positioned on the driver's side B-pillar. The label defines the recommended tire inflation pressure, load limits and maximum load of passengers and luggage weight the vehicle can safely carry. This label is specific to each individual vehicle and it is installed on the production line.

The label must not be removed from the vehicle. The label information only defines the specification of the vehicle as it came off the production line. It does not include retailer or owner mounted accessory wheels and tires of differing size from the original equipment.

## DESCRIPTION

### TIRE LOCATION

There are different pressure targets and thresholds for the front and rear tires, the Tire Pressure Monitoring System (TPMS) identifies the location of the tires. The TPMS system assigns received tire pressure sensor identification to a specific position on the vehicle, for example, front left.

The TPMS locates the position of the tire automatically. This function requires no manual intervention by the driver. The TPMS automatically learns the position of tires on the vehicle if the tire pressure sensors or their positions are changed on the vehicle.

The tire learn and location process is ready to start, when:

- The vehicle is stationary.
- The vehicle is travelling at less than 20 km/h (12.5 mph) for 15 minutes (parking mode).

The tire learn and location process requires the vehicle to be driven at speeds greater than 20 km/h (12.5 mph) for 15 minutes. If the vehicle speed reduces below 20 km/h (12.5 mph), the learn process timer is suspended. The timer is suspended until the vehicle speed increases to more than 20 km/h (12.5 mph). Then the timer is resumed. If the vehicle speed remains below 20 km/h (12.5 mph) for more than 15 minutes, the timer is set to zero. Then the process starts again.

The TPMS can automatically detect, under all operating conditions, the following:

- If 1 or more tire pressure sensors have been replaced.
- If 1 or more tire pressure sensor identifications are missing.
- Identifications from tire pressure sensors, which do not belong to the vehicle.
- If 1 of the tires in use on the vehicle has changed position.

- If 1 or more incompatible tire pressure sensors have been installed.
- If a full-size spare wheel is swapped with a running wheel.

If the tire pressure sensors installed to the running wheels are changed, the TPMS can learn the new tire pressure sensor identifications automatically. The learn function requires no manual intervention by the driver.

#### TIRE PRESSURE MONITORING SYSTEM CONTROL MODULE

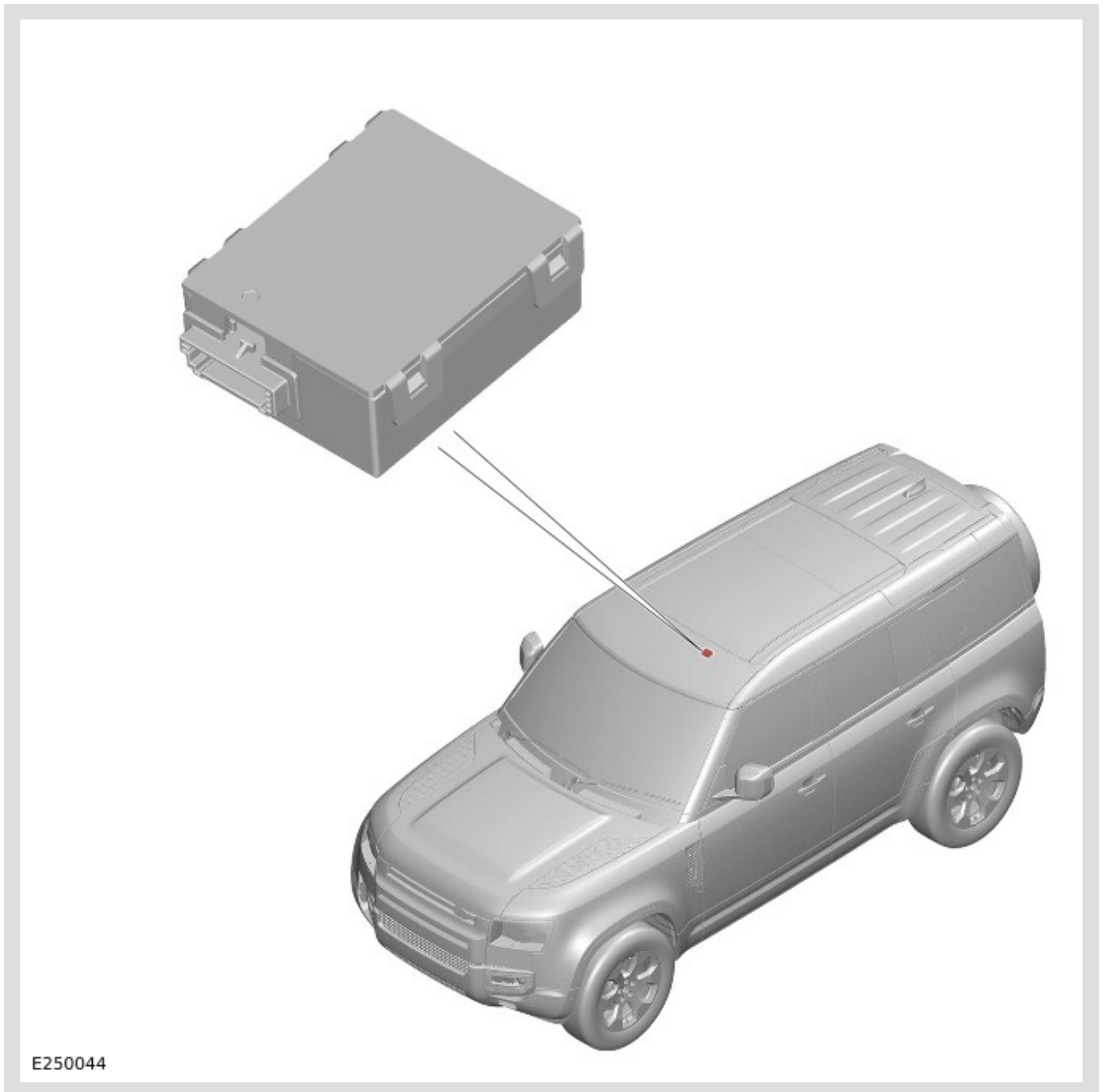

The Tire Pressure Monitoring System Control Module (TPMSCM) is mounted on the left side of the headliner, adjacent to the overhead console. The TPMSCM connects to the vehicle harness via a 6-pin plug.

The TPMSCM receives transmissions from each of the tire pressure sensors via an internal antenna in each of the sensors. A Radio Frequency (RF) receiver is integrated into the TPMSCM. This information is then decoded and analyzed. Any required warnings along with current tire pressure information is communicated on the High Speed (HS) Controller Area Network (CAN) Underbody (UN) systems bus.

## TIRE PRESSURE SENSOR

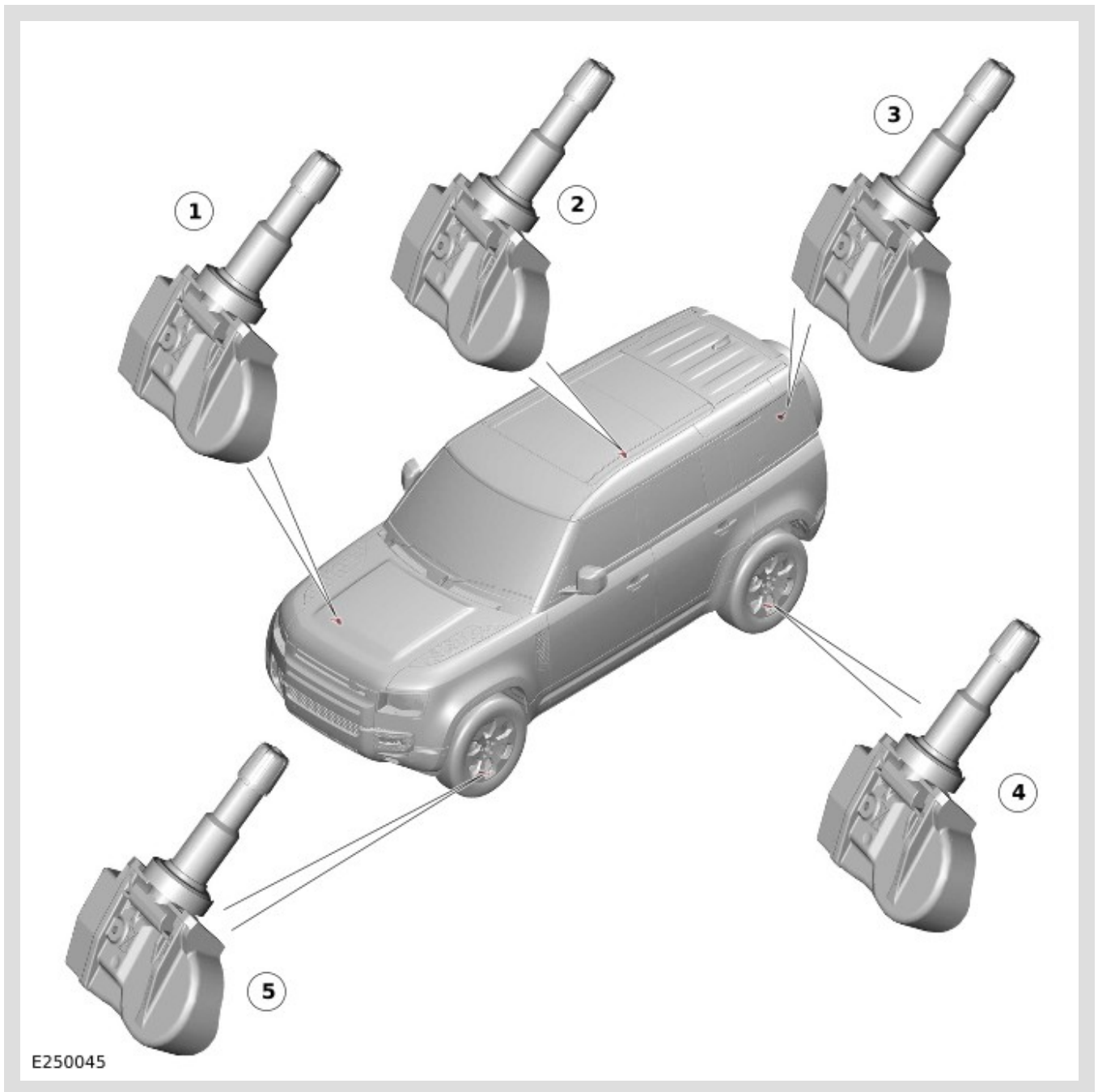

ITEM	DESCRIPTION
1	Tire pressure sensor - Front right wheel
2	Tire pressure sensor - Rear right wheel
3	Tire pressure sensor - Spare wheel
4	Tire pressure sensor - Rear left wheel
5	Tire pressure sensor - Front left wheel

The Tire Pressure Monitoring System (TPMS) uses 'active' tire pressure sensors which are mounted on each wheel, inside the tire cavity. The sensor is retained in position by the valve attachment to the wheel structure. The sensors transmit their Radio Frequency (RF) signals at 433 MHz.

The sensors periodically measure the pressure and temperature of the air inside the tire plus the centripetal acceleration acting on the sensor. These measurements are transmitted periodically to the RF receiver located in the Tire Pressure Monitoring System Control Module (TPMSCM) behind the front overhead console.

The tire pressure sensors are self contained units which have no electrical connections into or out of the sensor. The tire pressure sensors are powered by an embedded battery, inside the sensor housing.

The care points detailed in the 'Tires' section of the 'Operation' chapter must be followed to avoid damage to the sensor. If the sensor is replaced, the nut, seal and washer must also be replaced. The sensor must be tightened to the correct torque value as given in the service repair manual.

The RF transmission from the tire pressure sensor contains a unique identification code in its transmission data. The TPMSCM can identify the tire on the vehicle. If the sensor is replaced on a 'running' wheel, the identification for that sensor may be programmed into the TPMSCM. The TPMSCM must be programmed using the Jaguar Land Rover (JLR) approved diagnostic equipment. That wheel is not monitored until it is programmed, or until the wheel is learned by the vehicle, which can take up to 15 minutes. The identification code is on a label with the complete wheel and tire assembly when new and is printed on the housing of each sensor.

In order to conserve battery power, the TPMSCM uses different RF transmission rates when the wheel is stationary or moving. The wheel speed required to change between stationary and moving transmission rates is very low to allow for slow off road driving.

#### INSTRUMENT CLUSTER WARNING INDICATIONS



The Tire Pressure Monitoring System (TPMS) shows an amber warning indicator and a text message in the Instrument Cluster (IC) message center.

The warning indicator and message center are controlled by High Speed (HS) Controller Area Network (CAN) Human Machine Interface (HMI) systems bus messages. These messages are received from the Tire Pressure Monitoring System Control Module (TPMSCM). The TPMSCM sends messages to the Body Control Module/Gateway Module (BCM/GWM) on the HS CAN Underbody (UN) systems bus. The BCM/GWM transmits the messages to the IC on the HS CAN HMI systems bus.

The IC illuminates the warning indicator continuously when the tire pressure is low. The warning indicator flashes for 75 seconds and then illuminates continuously in a case of a failure.

For additional information, refer to:

[Instrument Panel Cluster](#) (413-01 Instrument Cluster, Description and Operation),

[Message Center](#) (413-08 Message Center, Description and Operation).

### HIGH SPEED CONTROLLER AREA NETWORK HUMAN MACHINE INTERFACE SYSTEMS BUS

The Tire Pressure Monitoring System Control Module (TPMSCM) sends and receives a number of digital messages. The messages are transmitted via the High Speed (HS) Controller Area Network (CAN) Human Machine Interface (HMI) systems bus. The received messages are used to operate the Tire Pressure Monitoring System (TPMS). The transmitted messages comprise of TPMS status, warning and pressure information and requests to the Instrument Cluster (IC). The IC has to turn on or off the warning indicator and/or display messages in the message center.

The TPMSCM transmits the messages shown in the following table:

MESSAGE	RECEIVED BY
TPMS diagnostic response	The Jaguar Land Rover (JLR) approved diagnostic equipment
TPMS amber warning indicator request at 25% (or 20% depending on market) tire deflation	Instrument Cluster (IC)
TPMS message display request	IC
Current tire pressures	IC
Recommended tire pressure data, to inflate tires to	IC

## OPERATION

### TIRE PRESSURE MONITORING SYSTEM

#### NOTE:

An Anti-lock Brake System (ABS) fault does not cause the Tire Pressure Monitoring System (TPMS) to stop operating. However, if an ABS fault persists then the auto location may fail and a TPMS warning may also display in the Instrument Cluster (IC).

Each time the vehicle is driven, the Tire Pressure Monitoring System (TPMS) learns the locations of the 4 tire pressure sensors. The TPMS learns the locations by combining the Radio Frequency (RF) transmissions with data from the Anti-lock Brake System (ABS) control module.

The system enters parking mode after the vehicle speed less than 20 km/h (12.5 mph) for 15 minutes. In parking mode, the tire pressure sensors transmit a coded signal to the TPMS module once every 6 hours. If the tire pressure decreases by more than 0.07 bar (1 psi), the sensor transmits more often to indicate tire pressure lost.

### **Auto Location**

The process of locating the sensors is known as 'Auto Location' and takes up to 10 minutes to complete. During this period, the tire pressure sensors transmit signals at regular intervals, once every 15 seconds. The vehicle speed must be above 20 km/h (12.5 mph).

After auto location is complete, the tire pressure sensors transmit once every 60 seconds (also when a tire pressure change is sensed). When the vehicle speed remains below 20 km/h (12.5 mph) (including stationary) for more than 15 minutes, the vehicle returns to parking mode. The auto location process is ready to start again.

At 25% deflation (or 20% for the EU market), the amber warning indicator in the Instrument Cluster (IC) illuminates. An appropriate message and/or a graphic also appears in the message center.

### **DIAGNOSTICS**

The Tire Pressure Monitoring System Control Module (TPMSCM) has a diagnostic connection via the High Speed (HS) Controller Area Network (CAN) Underbody (UN) systems bus. The HS CAN UN systems bus connection allows the Jaguar Land Rover (JLR) approved diagnostic equipment to retrieve the system status and faults.

Additionally, an onboard diagnostic routine within the TPMSCM constantly monitors the system. The driver is alerted to system faults by illuminating the amber warning indicator on the Instrument Cluster (IC). The IC also displays a message in the message center in case of a fault.

### **FAULT DETECTION**

If a tire pressure sensor fails, the amber warning indicator in the Instrument Cluster (IC) is illuminated. An additional message, 'XX Tire Not Monitored' is displayed in the message center.

'XX' denotes the tire position on the vehicle:

- FL - Front left
- FR - Front right
- RL - Rear left
- RR - Rear right.

If more than 1 sensor fails or the TPMS develops a fault, the amber warning indicator illuminates. The message center displays the following message: 'Tire Monitoring System Fault'. This fault could also be caused if Radio Frequency (RF) interference near the vehicle affects the system signal reception. For example: laptop chargers, Direct Current (DC) to Alternating Current (AC) converters, navigation systems. When the interference has ceased, the fault will be automatically cancelled and the TPMS will operate normally.

If a tire pressure sensor battery fails, the sensor stops transmitting. The TPMS transmits a message to display for example: 'FL Tire Not Monitored'. The retailer should interrogate the TPMS using the Jaguar Land Rover (JLR) approved diagnostic equipment to determine the cause of the message. The tire pressure sensor maybe in 'Ship' mode and a handheld Low Frequency Tool can be used to set into 'Park' mode. If the sensor has failed, the sensor must be replaced and the stored faults removed using the JLR approved diagnostic system.

## TIRES

### ⚠ CAUTION:

Care must be taken when remove and install tires to make sure, that the tire pressure sensor is not damaged.

### △ NOTES:

- Service the tire pressure sensor valve with a suitable service kit each time the tire is dismantled. Make sure that the seal is air tight. Follow all instructions about using this kit.
- If the metal valve stem of the tire pressure sensor is damaged, it can be replaced independently. The metal valve stem is a separate component and there is no need to replace the entire sensor assembly.

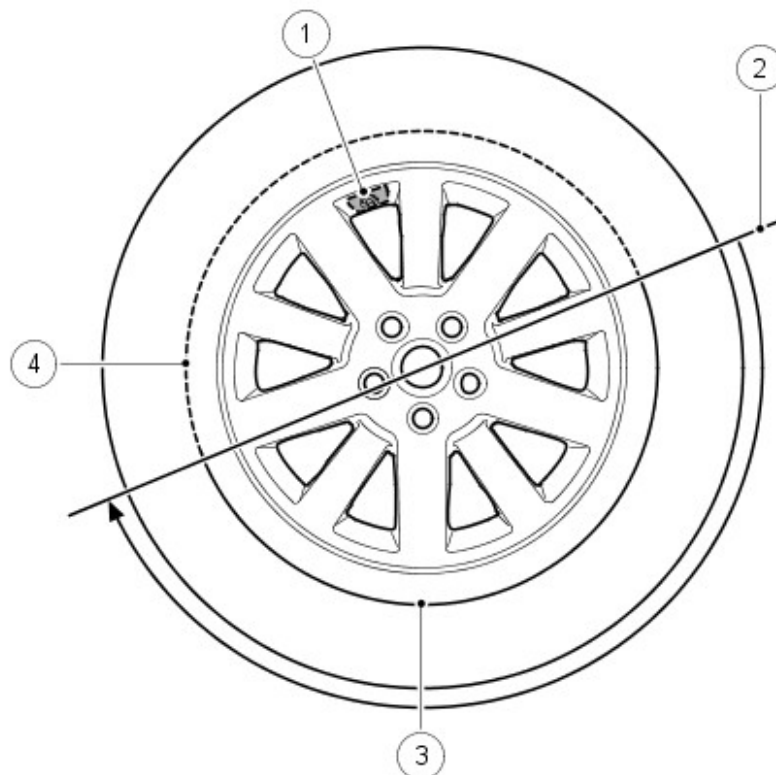

E45549

ITEM	DESCRIPTION
1	Tire valve and pressure sensor
2	Tire installation/removal tool initial start position

ITEM	DESCRIPTION
3	High tire and bead tension area
4	Low tire and bead tension area

During tire removal the bead breaker must not be used within 90° of the tire valve in each direction.

When using the tire removal machine, the mounting arm start position must be positioned as shown in the tire changing illustration. The wheel can then be rotated through 180° in a counter clockwise direction. This relieves the high tension from the tire bead and allows, that the remaining 180° of the tire can be manually pulled from the rim.

During tire installation, position the mounting arm as shown in the tire changing illustration. Rotate the tire and take care that the bead on the low tension side of the tire does not damage the tire pressure sensor.

CONTROL DIAGRAM

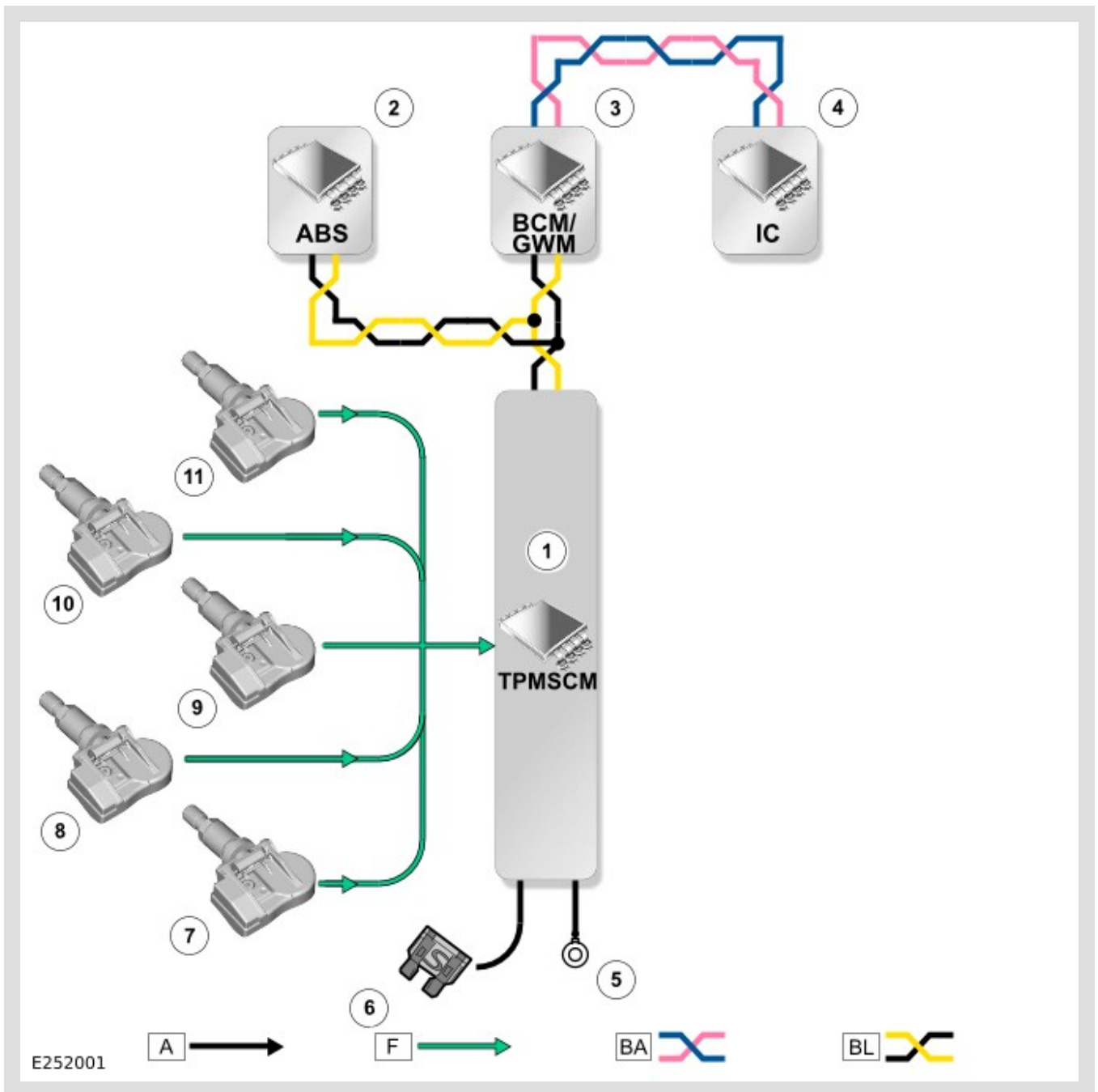

A = HARDWIRED: F = RADIO FREQUENCY (RF) TRANSMISSION: BA = HIGH SPEED (HS) CONTROLLER AREA NETWORK (CAN) HUMAN MACHINE INTERFACE (HMI) SYSTEMS BUS: BL = HS CAN UNDERBODY (UN) SYSTEMS BUS.

ITEM	DESCRIPTION
1	Tire Pressure Monitoring System Control Module (TPMSCM)
2	Anti-lock Brake System (ABS) control module
3	Body Control Module/Gateway Module (BCM/GWM)

ITEM	DESCRIPTION
4	Instrument Cluster (IC)
5	Ground
6	Power supply
7	Tire pressure sensor - Rear right wheel
8	Tire pressure sensor - Spare wheel
9	Tire pressure sensor - Rear left wheel
10	Tire pressure sensor - Front left wheel
11	Tire pressure sensor - Front right wheel