

REAR DOOR TRIM PANEL

Service repair no - 76.34.09

Remove

1. Remove the two screws securing the door pull and remove it from the door.
2. Remove the finisher from the inner door handle.
3. Using a trim panel removing tool release the seventeen trim panel fasteners and withdraw the panel from the door.

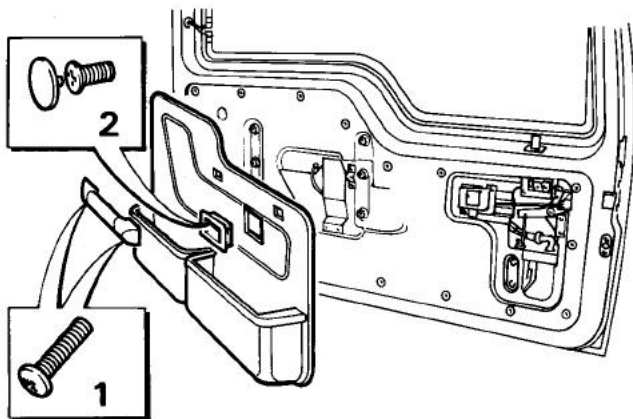

J5010M

4. If necessary remove the sixteen screws securing the storage bins to the trim panel and detach the bins.

Refit

5. Reverse removal procedure.

REAR DOOR LOCK AND INNER AND OUTER RELEASE HANDLES

Service repair no - 76.37.16/74/77/78

Remove

1. Disconnect battery negative lead.
2. Remove the door pull, the trim panel and the vapour protective sheet, to allow access to the door handles and lock mechanisms.
3. Disconnect the inner release handle connecting rod at the lock.
4. Remove the two screws securing the inner handle and withdraw the handle complete with connecting rod.



NOTE: Two identical 'Y' shaped levers (bellcranks) are fitted to the rear door lock mechanism and are referred to as inner and outer 'Y' levers; the inner one being the nearest to the inner door panel.

5. If fitted, remove the central locking actuator control rod link from the actuator and from the inner 'Y' lever.

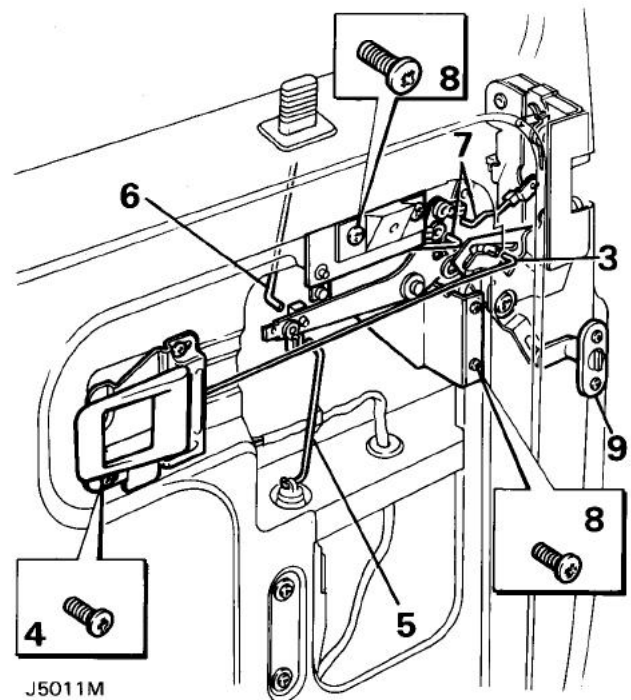

J5011M

6. Detach the remote button connecting rod at the inner 'Y' lever and withdraw from inside the door.
7. Detach the lock and barrel connecting rods from the upper leg of the inner 'Y' lever.



8. Remove the screws securing the lock control mechanism pivot bracket and the door pull mounting bracket, ease the bracket from the lock barrel stem and remove from the door.
9. Remove the two screws and withdraw the childproof lock actuator.

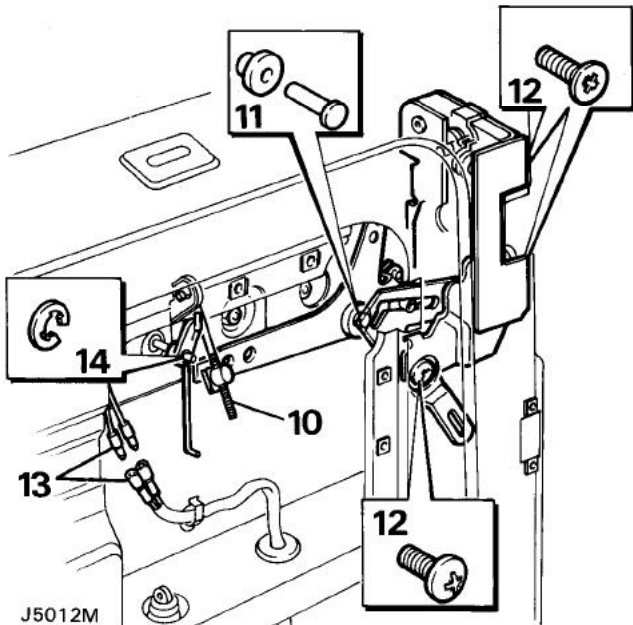

J5012M

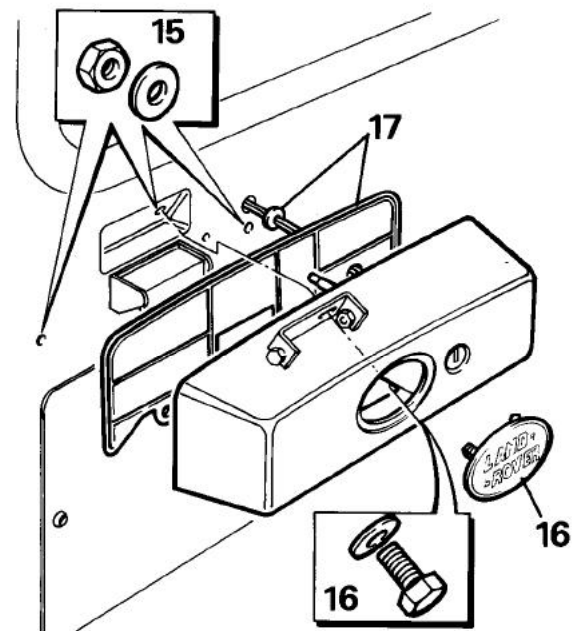

J5013M

18. Remove the connecting rod from the outer door handle lever.
19. Remove the two nuts and washers securing the outer handle from inside the door panels and detach the handle and seal.

10. Disconnect the adjustable lock rod from the outer 'Y' lever.
11. Remove the centre pin from the outer 'Y' lever pivot and release the pivot from the door.
12. Remove the three lock securing screws and manoeuvre the lock and 'Y' lever out of the door panels.
13. Disconnect the number plate light leads from the door harness.
14. Remove the 'E' clip securing the fulcrum to the barrel stem and withdraw the fulcrum and lock rod.
15. From inside the door panel remove the nuts and washers securing the lock barrel and number plate light housing.
16. Remove the logo from the housing and working through the logo aperture, remove the single bolt securing the housing.
17. Partially withdraw the housing and its rubber seal from the door, displace the rubber grommet from the door panel, withdraw the number plate light leads and complete the removal of the housing and seal from the door.

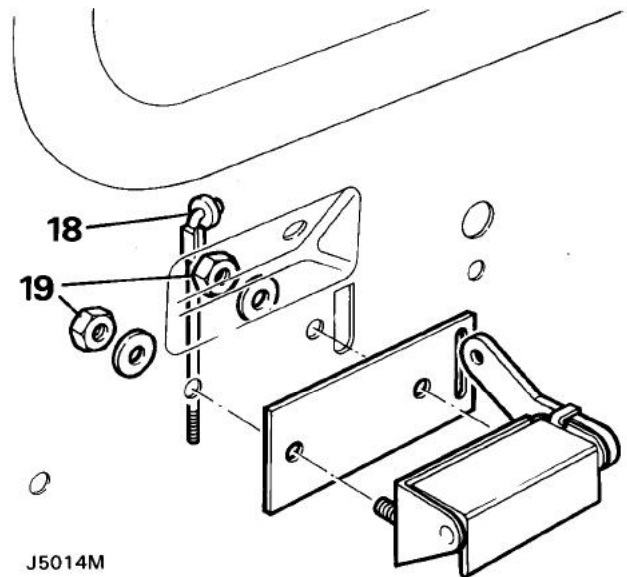

J5014M

Lock barrel and number plate light housing

Disassemble



NOTE: The lock barrel can only be removed from its housing when the lock barrel and number plate light housing is removed from the door.

20. Remove the bolt securing the lock barrel mounting bracket to the housing and withdraw the assembled barrel and bracket.
21. Remove the 'O' ring seal from inside the housing.

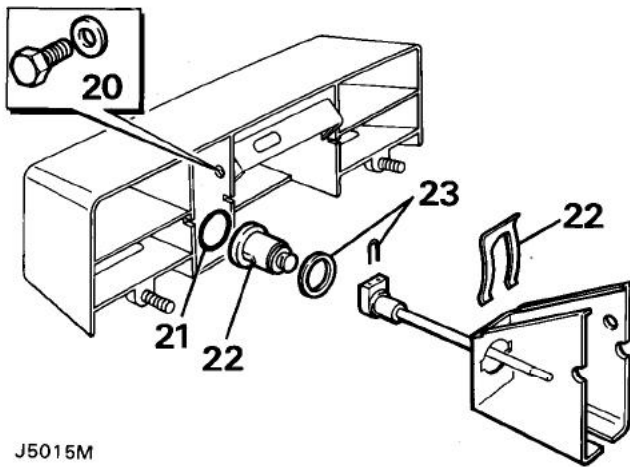

J5015M

22. Remove the spring clip securing the barrel to the bracket and withdraw the barrel and stem assembly from the bracket complete with seal.
23. Remove the 'U' clip securing the stem to the barrel and detach the seal from the inner face of the barrel.
24. If the lock barrel and number plate light housing is being renewed, remove the number plate lights, harness and the housing mounting bracket, from the existing housing and fit them to the new housing.

Reassemble

25. Fit the stem to the barrel and secure with the 'U' clip.
26. Position a new seal on the inner face of the barrel, insert the stem and barrel into the mounting bracket and secure with the spring clip.
27. Place a new 'O' ring seal on the inner face of the barrel aperture in the housing.
28. Insert the assembled bracket and barrel into its location in the housing, taking care not to disturb the seal, and secure with the bolt.

Refit

29. Fit the outer handle to the door and secure from the inside with the two nuts and washers.
30. Fit the lock barrel and number plate light housing by inserting the number plate light leads through the aperture in the door panel and locating the rubber grommet in the aperture. Insert the barrel stem through the door, locate the housing on the door panel, ensure that the seal seats correctly, and secure with the single bolt and washer through the logo aperture.
31. Connect the number plate light leads to the door harness.
32. Fit the logo to the aperture in the housing.
33. Fit the fulcrum and connecting rod to the barrel stem and secure with secure with the 'E' clip.
34. Fit the lock and assembled outer 'Y' lever, secure the lock with the three screws, locate the 'Y' lever pivot and secure with the pin.
35. Fit the connecting rod from the outer handle lever to the outer 'Y' lever.
36. Fit the childproof lock actuator and check that it is functioning.
37. Insert the remote button and rod to the location in the door.
38. Offer up the assembled inner 'Y' lever and bracket, attach the barrel connecting rod to the top clip of the upper leg and the rod from the lock to the lower clip of the upper leg.
39. Locate the barrel stem in the insert on the bracket.
40. Secure the bracket with the four screws; fitting the door pull mounting bracket under the heads of the top two screws.
41. Attach the remote button and the actuator connecting rods to the 'Y' lever.
42. Fit the inner release handle and attach the connecting rod to the lock.
43. Refit the vapour protective sheet, door trim panel and door pull.