



## REAR SIDE DOOR LOCK, INSIDE AND OUTSIDE RELEASE HANDLES

Service repair no - 76.37.13/32

### Remove

1. Ensure that the window is in the fully closed position.
2. Disconnect battery negative lead.
3. Remove the interior trim panel from the door.  
**See this section.**
4. Remove the plastic vapour barrier sheet.
5. Disconnect the inside release handle control rod by pulling it from its location in the door lock.
6. Disconnect the sill locking control rod from the lock by releasing the metal clip.
7. Disconnect the outside release handle control rod by pulling it out of the plastic ferrule.
8. Remove the two countersunk screws from the door edge and the single screw and shakeproof washer from the inner door panel. Retrieve any spacing washers which may be fitted between the inner door panel and lock.
9. Withdraw the lock through the upper rear opening in the inner door panel.

 **NOTE:** If necessary the following items can be removed.

10. Remove the two nuts, shakeproof washers and retaining bracket securing the outer release handle which are accessible through the upper rear cut-out on the inner door panel.
11. Carefully detach the handle from the outer door panel.
12. Remove the two screws and plain washers securing the inside release handle to the inner door panel and withdraw the handle complete with connecting rod.
13. Disconnect the sill button connecting rod from the bellcrank and withdraw the rod complete with sill button.

### Sill locking bellcrank

14. Using a small screwdriver, or length of 3.175 mm (1/8 in) diameter rod, press the plastic locking pins through the respective square inserts in the inner door panel.
15. Release the bellcranks from the inner door panel and unhook the respective connecting rods.
16. Withdraw the bellcranks from inside the door panels.

 **NOTE:** When refitting the bellcranks the locking pins are entered into the square insert from outside and pressed in flush.

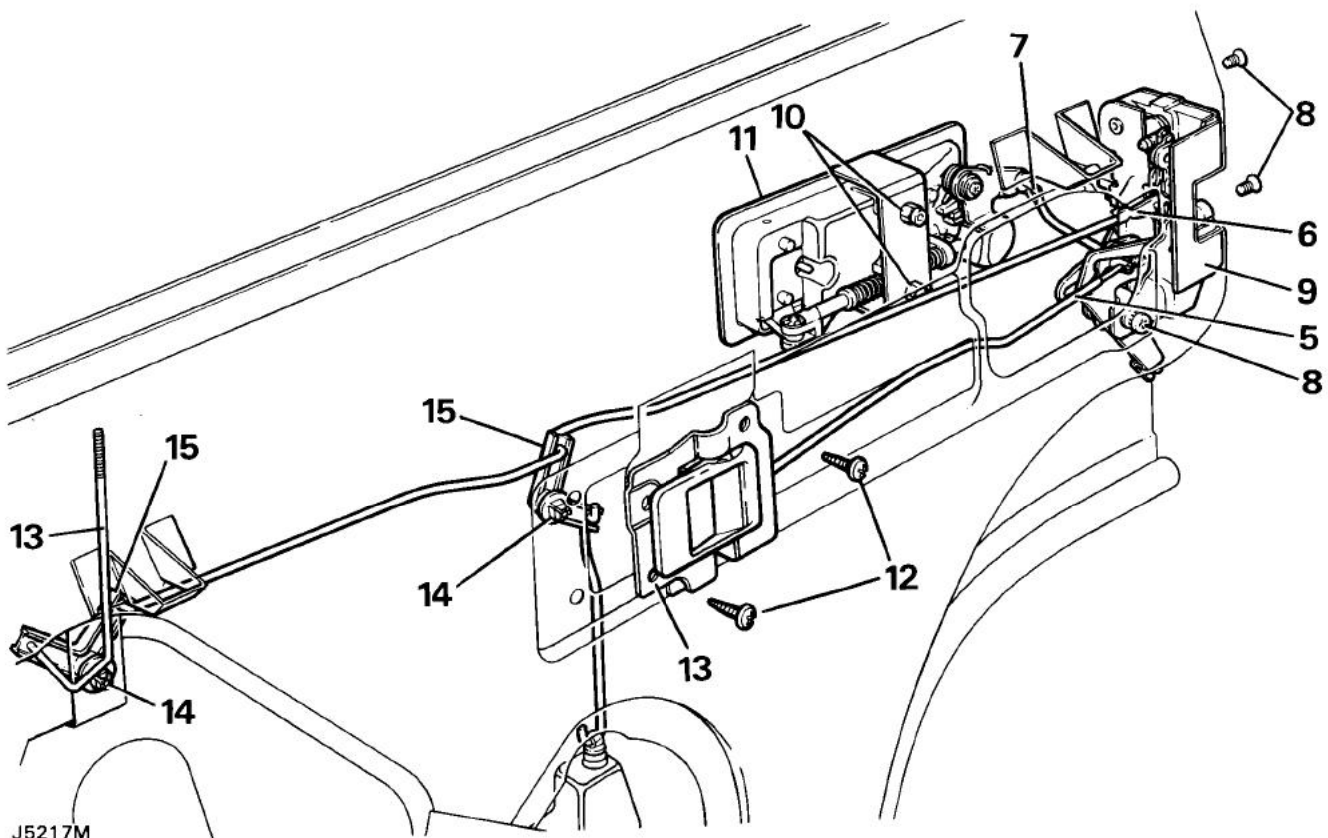

J5217M

**ADJUSTMENT-REAR SIDE DOOR LOCK AND HANDLE**

Service repair no - 76.37.47

**Outside door release handle to lock**

1. Disconnect the short off-set connecting rod at the rear of the outer release handle, rotate the rod clockwise or counter clockwise to shorten or extend the operating length of the rod as required.

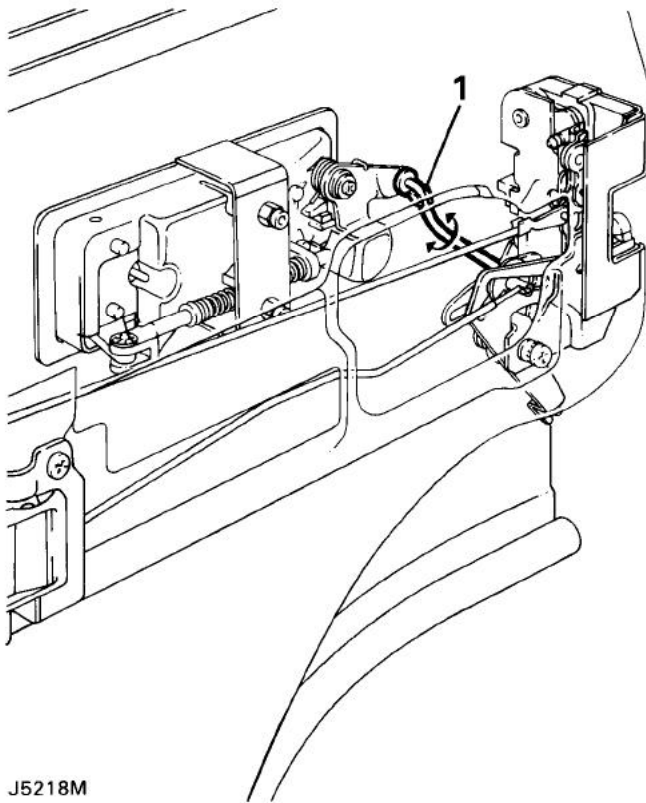

**NOTE:** Door release should occur before the total handle movement is achieved to provide a small overthrow movement.

**REAR SIDE DOOR GLASS AND REGULATOR**

Service repair no - 76.31.45

**Remove**

1. Ensure that the window is in the fully closed position and secure it with adhesive tape over the top of the door to prevent the glass from dropping down.
2. Disconnect battery negative lead.
3. Remove the door trim panel. *See this section.*
4. Remove the plastic vapour barrier.
5. Where applicable remove the door actuator and window lift motor. *See ELECTRICAL, Repair. See ELECTRICAL, Repair.*
6. Remove the four window regulator securing screws and shakeproof washers from the inner door panel.

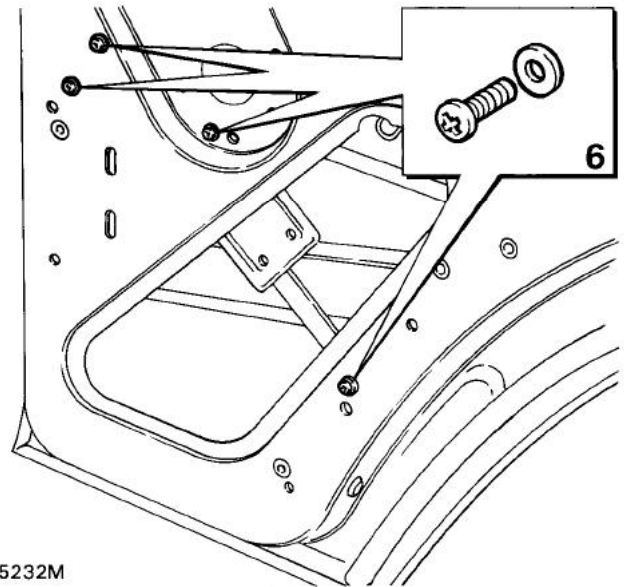

7. Carefully disengage the lifting arm stud from the glass lifting channel and remove the window regulator from the lower opening in the inner door panel.
8. Remove the waist rail seal from the top of the door panel.
9. Remove the single bolt, spring and plain washers from inside the door, securing the bottom of the short glass run channel.
10. Remove the two bolts, spring and plain washers from the hinge face of the door.