

**CIRCUIT OPERATION****Starting System (MFI–V8) (300 Tdi without EGR)**

For vehicles equipped with Theft Alarm without Engine Immobilisation:

Putting the Ignition Switch (X134) in position III applies battery voltage to the Starter Solenoid Relay's (K137) terminal 85. With the vehicle in Park or Neutral (Automatic only) and the Theft Alarm de-activated, the Starter Solenoid Relay (K137) energises. Battery voltage is then applied directly to the Starter Solenoid (K136) and the Starter (M134) via the Engine Immobilisation Control Unit (Spider) (Z271) shorting plug.

On manual transmission vehicles, the Theft Alarm Unit (Z163) provides a ground circuit to the Starter Solenoid Relay's (K137) 86 terminal.

On automatic transmission vehicles, the Theft Alarm Unit (Z163) provides a ground circuit to the Starter Solenoid Relay's (K137) 86 terminal via the Park/Neutral Position Switch (X167).

If the theft alarm is activated, the Theft Alarm Unit (Z163) will interrupt the Starter Solenoid Relay's (K137) ground path. The Starter Solenoid Relay (K137) will remain de-energised and prevent starting the engine.

For vehicles equipped with Theft Alarm and Engine Immobilisation:

Putting the Ignition Switch (X134) in position III applies battery voltage to the Starter Solenoid Relay's (K137) terminal 85. With the vehicle in Park or Neutral (Automatic only) and the Theft Alarm de-activated, the Starter Solenoid Relay (K137) energises. Battery voltage is then applied to the Engine Immobilisation Control Unit (Spider) (Z271).

If the Theft Alarm is activated, the Engine Immobilisation Control Unit (Spider) (Z271) will interrupt the battery supply to the Starter Solenoid (K136) and the Starter (M134).

On manual transmission vehicles, the Theft Alarm Unit (Z163) provides a ground circuit to the Starter Solenoid Relay's (K137) 86 terminal.

On automatic transmission vehicles, the Theft Alarm Unit (Z163) provides a ground circuit to the Starter Solenoid Relay's (K137) 86 terminal via the Park/Neutral Position Switch (X167).

If the theft alarm is activated, the Theft Alarm Unit (Z163) will interrupt the Starter Solenoid Relay's (K137) ground path. The Starter Solenoid Relay (K137) will remain de-energised and prevent starting the engine.

For vehicles not equipped with Theft Alarm and Engine Immobilisation:

Putting the Ignition Switch (X134) in position III applies battery voltage to the Starter Solenoid Relay's (K137) terminal 85. With the vehicle in Park or Neutral (Automatic only), the Starter Solenoid Relay (K137) energises. Battery voltage is then applied directly to the Starter Solenoid (K136) and the Starter (M134) via the Engine Immobilisation Control Unit (Spider) (Z271) shorting plug.

For vehicles not equipped with Theft Alarm, a black wire is used to short pins 10 and 11 of C274.

On Japan and manual transmission vehicles, a ground path is provided directly to the Starter Solenoid Relay's (K137) 86 terminal.

On automatic transmission vehicles, a ground path is provided to the Starter Solenoid Relay's (K137) 86 terminal via the Park/Neutral Position Switch (X167).

**Starting System (MFI–T16) (SFI–V8)  
(300 Tdi with EGR) (300 Tdi with EDC)**

Putting the Ignition Switch (X134) in position III applies battery voltage to the Starter Solenoid Relay's (K137) terminal 85. With the vehicle in Park or Neutral (Automatic only) and/or the Theft Alarm de-activated, the Starter Solenoid Relay (K137) energises. Battery voltage is then applied directly to the Starter Solenoid (K136) and the Starter (M134).

On manual transmission vehicles equipped with a theft alarm, the Theft Alarm Unit (Z163) provides a ground circuit to the Starter Solenoid Relay's (K137) 86 terminal.

On automatic transmission vehicles equipped with a theft alarm, the Theft Alarm Unit (Z163) provides a ground circuit to the Starter Solenoid Relay's (K137) 86 terminal via the Park/Neutral Position Switch (X167).

If the theft alarm is activated, the Theft Alarm Unit (Z163) will interrupt the Starter Solenoid Relay's (K137) ground path. The Starter Solenoid Relay (K137) will remain de-energised and prevent starting the engine.

For vehicles not equipped with Theft Alarm, a black wire is used to short pins 10 and 11 of C274.

**Charging System**

When the Ignition Switch (X134) is in position II, battery voltage is applied to the charging system fault light. When the Generator (Z106) is being turned by the engine, its stator windings are excited by voltage applied to the Generator (Z106) via the charging system fault light. The Generator (Z106) begins to produce electricity in order to charge the vehicle Battery (P104). If the Generator (Z106) fails to produce power, the Generator (Z106) grounds the fault light control wire, causing the charging system fault light to glow.

The tachometer displays engine speed in rpm. Voltage pulses are taken from the Generator (Z106) and are generated when the engine drive belt turns the Generator pulley. The tachometer responds to the frequency of the voltage pulses, which increases proportionally to that of the engine speed.

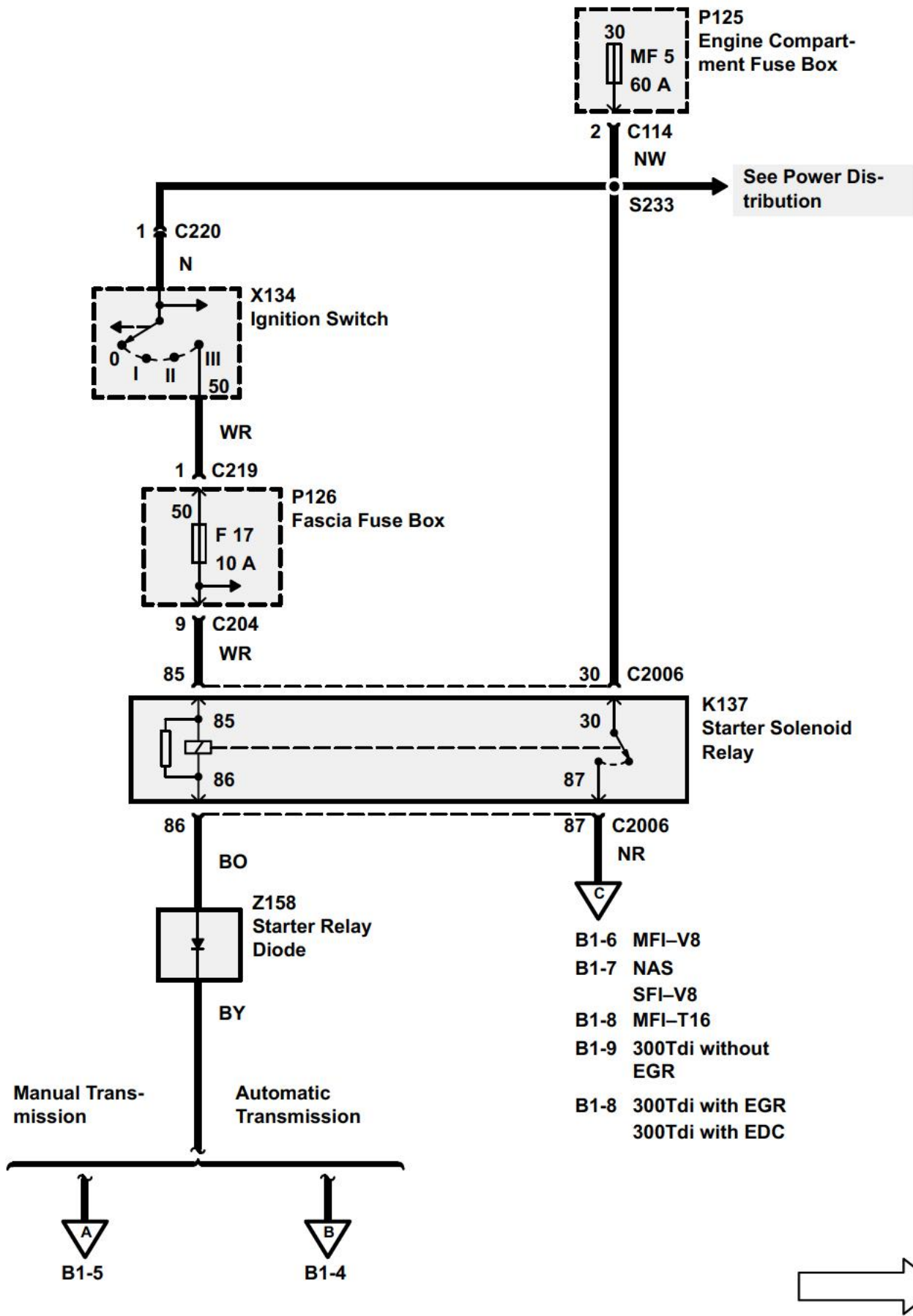

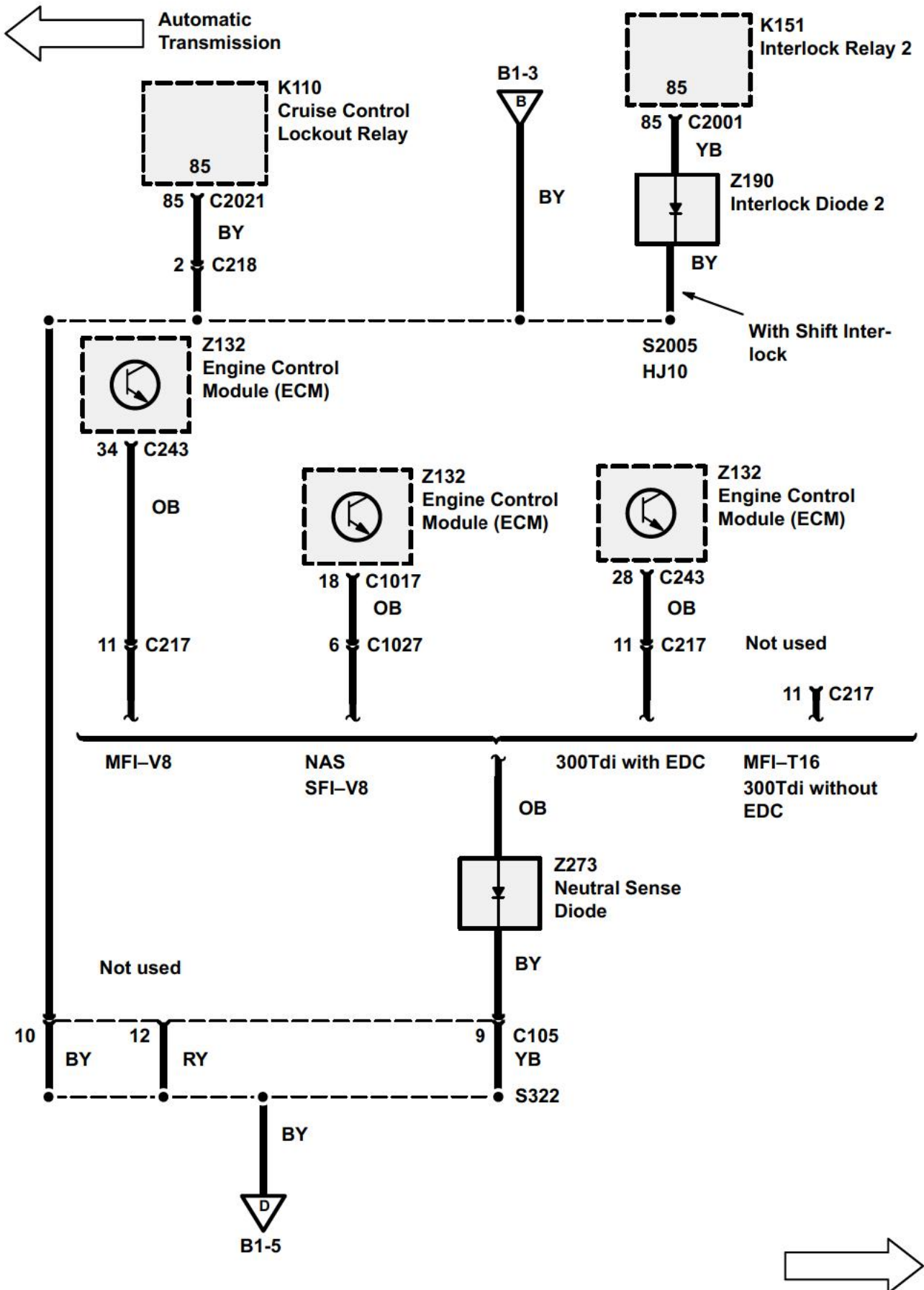

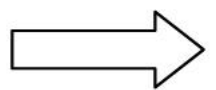
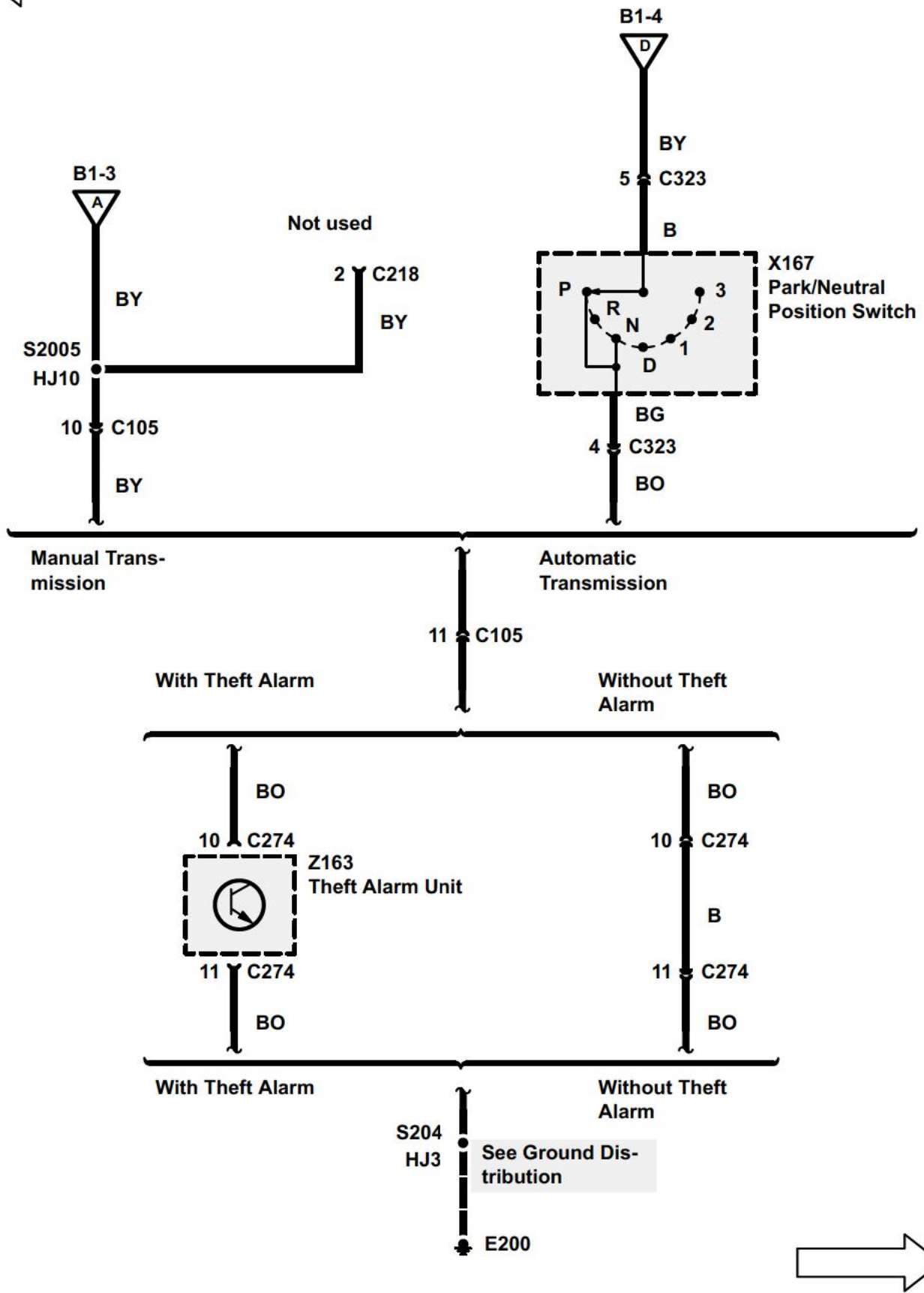
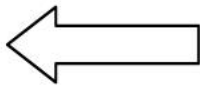

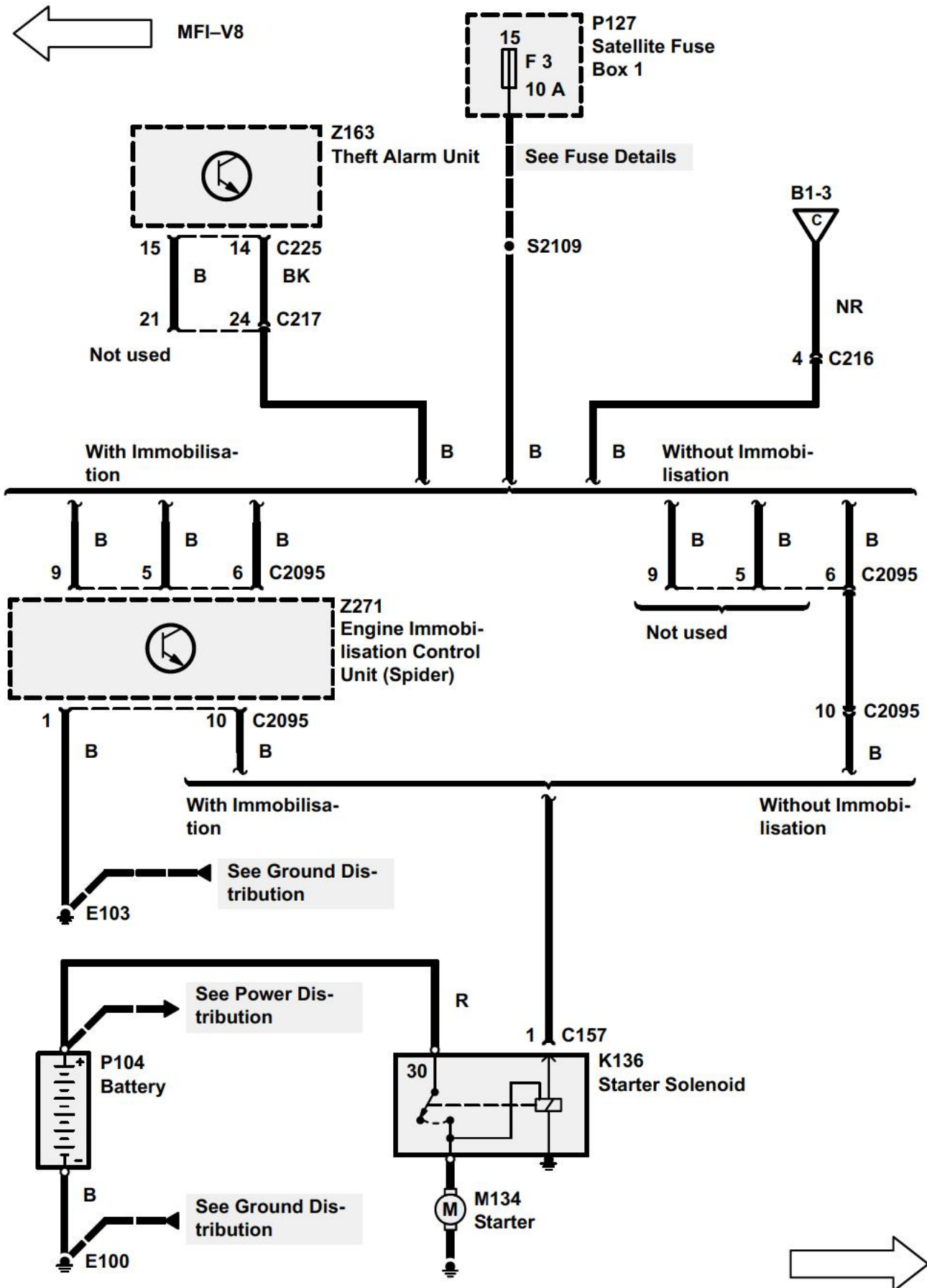

← NAS  
SFI-V8

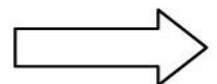
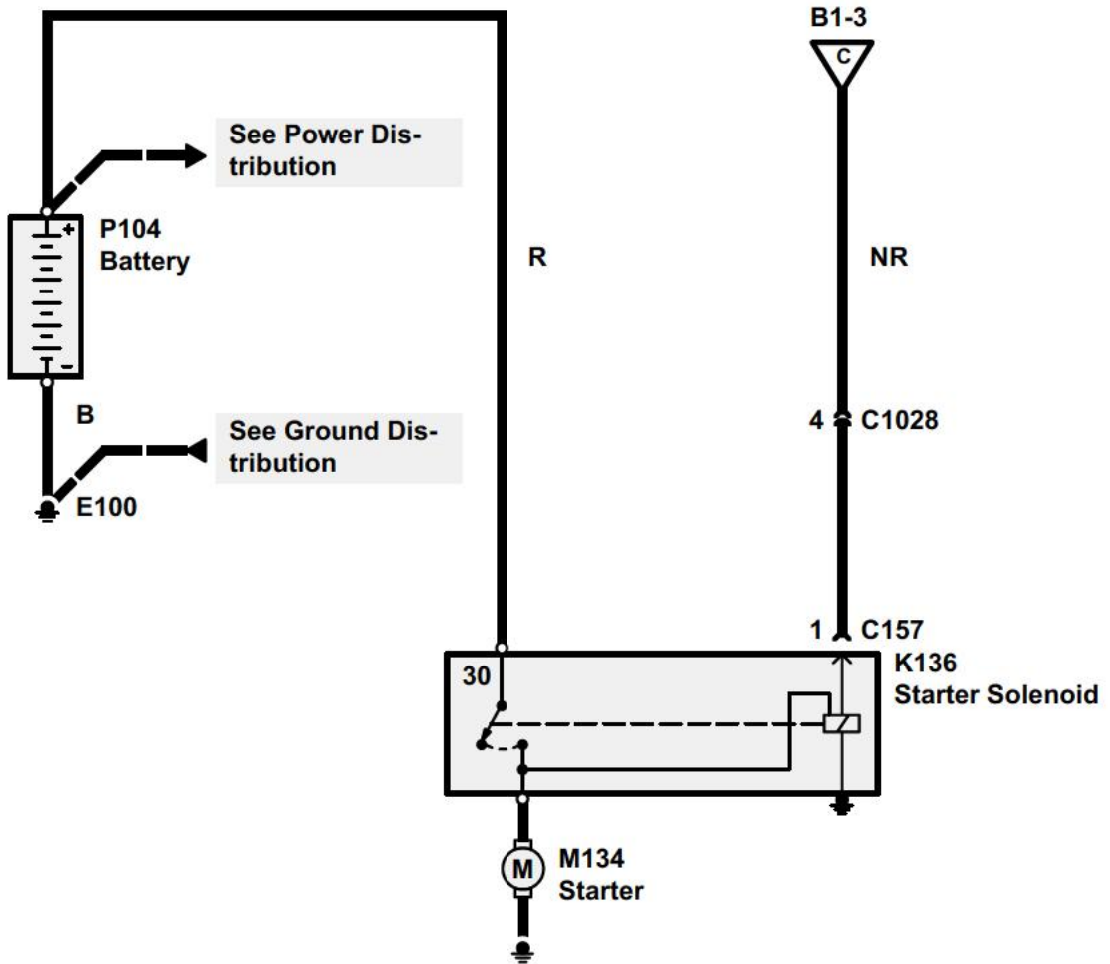



MFI-T16  
300Tdi with EGR  
300Tdi with EDC

