



## CAMSHAFT POSITION SENSOR (CMP SENSOR)

Service repair no - 19.22.07

### Remove

1. Disconnect battery negative lead.
2. Raise vehicle on a ramp.

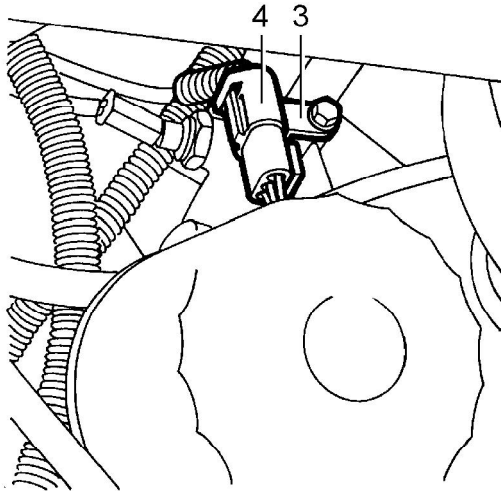

J6009

3. Release sensor multiplug from clip located on front cover.
4. Disconnect multiplug.

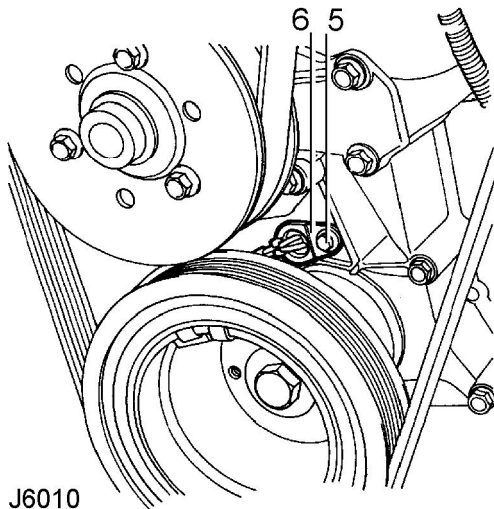

J6010

5. Remove bolt securing sensor.
6. Remove sensor from front cover.
7. Remove 'O' ring from sensor and discard.

### Refit

8. Clean sensor and mating face on front cover.
9. Lubricate NEW 'O' ring and fit to sensor.
10. Engage CMP sensor in front cover location. Secure with bolt. Tighten to **8 Nm**.
11. Connect sensor multiplug and secure to bracket.
12. Lower ramp.
13. Reconnect battery negative lead.