

RR2894E

FUEL INJECTION - Circuit Diagram - 1989 Model Year

- | | |
|---|--|
| <ol style="list-style-type: none"> 1. 40 way connector to Electronic Control Unit (ECU). 2. Lambda sensor (left side - bank A). 3. Lambda sensor fright side - bank B). 4. By-pass air valve (stepper motor) (fast idle). 5. Lambda sensor screened ground. 6. Fuse 18 - main fuse panel. 7. Inertia switch. 8. Fuel pump. 9. Ignition switch. 10. Speed transducer (road speed input). 11. Neutral switch (automatic gearbox) (load input). 12. Main cable connector. 13. Battery. 14. Diagnostic plug. 15. In-line resistor. 16. Coil/-ve (engine RPM input). 17. Coolant temperature thermistor (sensor) (input). | <ol style="list-style-type: none"> 18. Fuel temperature thermistor (sensor) (input). 19. Throttle potentiometer. 20. Air flow sensor. 21. Fuel pump relay. 22. Main relay. 23. Injectors-I to 8. 24. Pick-up point E.F.I. warning symbol (instrument binnacle). 25. Heated front screen sense. 26. Purge control valve. 27. 12V from fan relay. 28. Air conditioning switch sense. 29. Air conditioning output control. 30. Air conditioning load input. 31. Fan relay feed. 32. Heater/air con. cable connector. 33. Condenser fan timer control. |
|---|--|
- = = = Denotes screened ground.

NOTE: Reference to left and right side is made when viewing vehicle from rear.

FUEL INJECTION SYSTEM

For 1989 model year, the EFI system has a Lucas 14CU electronic control unit. This is a development of the 13CU used on 3.5 litre vehicles.

In most respects the 14CU works in the same way using the same engine components, it does however have additional capacity, enabling it to control fuel tank vapour purging and air conditioning.

Condenser fans

It should be noted that under high coolant temperatures, when the engine is switched off, the condenser fans will be activated and will run for approximately ten minutes.

Throttle potentiometer

A further improvement is the fitting of a 'self adaptive' throttle potentiometer. This means that adjustment of the throttle potentiometer is no longer possible. It also means that the potentiometer setting is not lost, for example, when throttle stop wear occurs.

Purge valve

The operation of the charcoal canister purge valve is checked during the fuel injection system test. See TESTS 9 and 10 Section 19, page 48.

Recommended equipment

The diagnostic equipment used for checking out the 14CU system is the same as that used for 13CU, with the addition of a new memory card for the Hand held test unit.

14CU Memory card

Lucas Part Number - 54746500

CONTINUITY TEST PROCEDURE

Test procedure using a multi-meter is carried out as for 13CU, with the addition of tests for the purge control valve, air conditioning, heated front screen and condenser fan inputs.

The use of a hand held vacuum pump, for example a 'Mityvac', is required to carry out Tests 9 and 10.

Note that the 40 way multi-plug to the ECU is wired as in the following table.







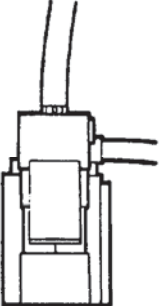
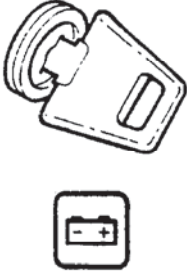
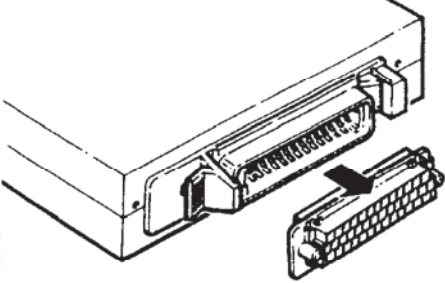

PIN NOS. CABLE COLOUR

1. Red/green
2. Brown/orange
3. Yellow
4. Black
5. Black/white
6. Yellow
7. Green/blue
8. Purple/yellow
9. White/light green
10. Black/Yellow
11. Yellow/white
12. Blue/red
13. Yellow/blue
14. Black
15. Brown
16. Blue/purple
17. Grey/yellow
18. White/pink
19. White/grey
20. Red
21. Yellow/black
22. Blue/red
23. Blue
24. Blue
25. Red/black
26. Green/white
27. Black/grey
28. Blue/grey
29. Orange
30. Not used
31. Not used
32. Grey/white
33. Black/grey
34. Black/orange
35. Blue/green
36. Black/green
37. White/yellow
38. Not used
39. White/black
40. Black

The last colour denotes the wire tracer colour.

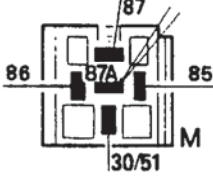
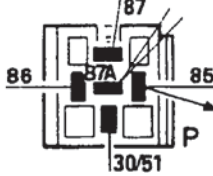
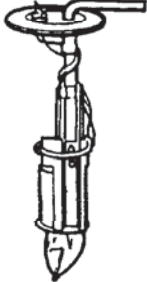
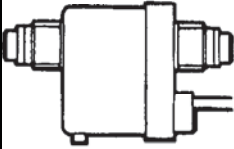
TESTS - Using a Multi-Meter - 14CU system - Key to Symbols

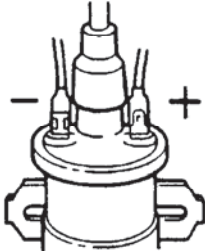
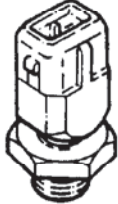
The following continuity tests are intended as a guide to identifying where a fault may be within a circuit; reference should be made to the fuel injection circuit diagram for full circuit information.

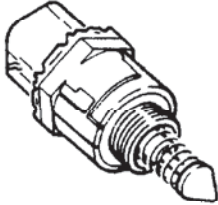
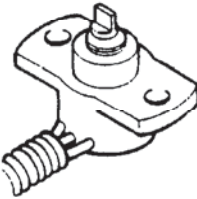
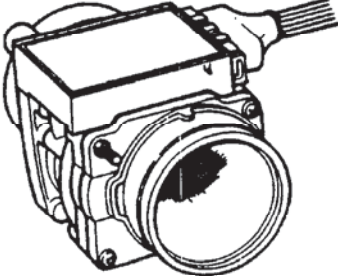
 <p>PURGE VALVE</p>	 <p>IGNITION SWITCH</p>	 <p>ELECTRONIC CONTROL UNIT AND MULTIPLUG</p>		 <p>TEMPORARY CONNECTION</p>
 <p>OHMMETER CONNECTIONS</p>	 <p>VOLTMETER CONNECTIONS</p>	 <p>MAIN RELAY</p>	 <p>PUMP RELAY</p>	 <p>FUEL PUMP</p>
 <p>ROAD SPEED INPUT (SPEED TRANSDUCER)</p>	 <p>GEAR INPUT SWITCH (INHIBITOR SWITCH)</p>	 <p>INJECTOR</p>	 <p>IGNITION COIL</p>	 <p>FUEL TEMPERATURE SENSOR</p>
 <p>COOLANT TEMPERATURE SENSOR</p>	 <p>AIR BYPASS VALVE</p>	 <p>THROTTLE POTENTIOMETER</p>	 <p>HOT WIRE AIRFLOW METER</p>	

RR2626E

NOTE: All tests are carried out from the electronic control unit (ECU) harness multi-plug unless stated otherwise in the test procedure.

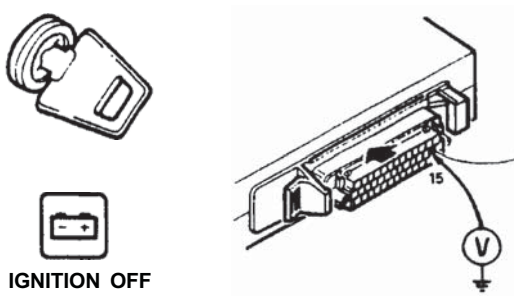
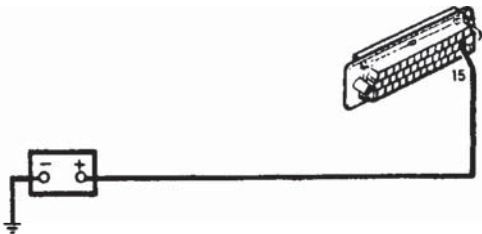
TEST PROCEDURE	RESULTS - Check cables and units shown in bold
<p>1. Check battery supply to ECU</p>	<p>Voltmeter reading of battery volts - (minimum battery voltage 10 volts) Proceed to Test 2 Voltmeter reading of zero volts Check:-</p>
<p>1</p>  <p>IGNITION OFF</p> <p>RR2627E</p>	

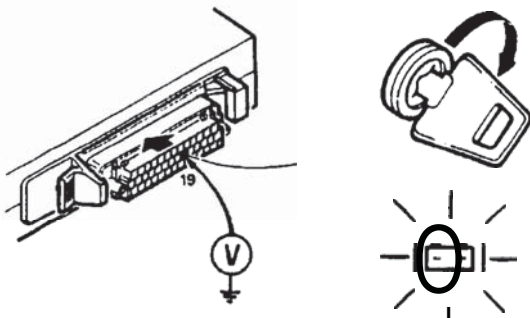
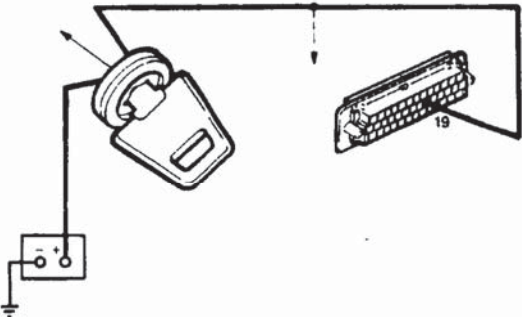
TEST PROCEDURE	RESULTS - Check cables and units shown in bold
<p>2. Check ignition supply to ECU</p>	<p>Voltmeter reading of battery volts - (minimum battery voltage 10 volts) Proceed to Test 3 Incorrect reading check:-</p>
<p>2</p>  <p>IGNITION ON</p> <p>RR2628E</p>	

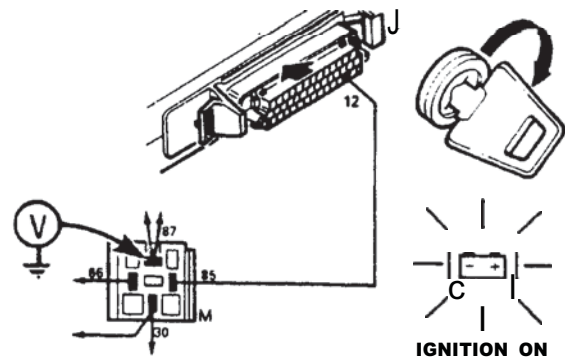
TEST PROCEDURE	RESULTS - Check cables and units shown in bold
<p>3. Check operation of Main relay</p>	<p>Voltmeter reading of battery volts - Proceed to Test 5</p>
<p>3</p>  <p>RR2629E</p>	<p>Voltmeter reading of zero volts - Proceed to Test 4</p>

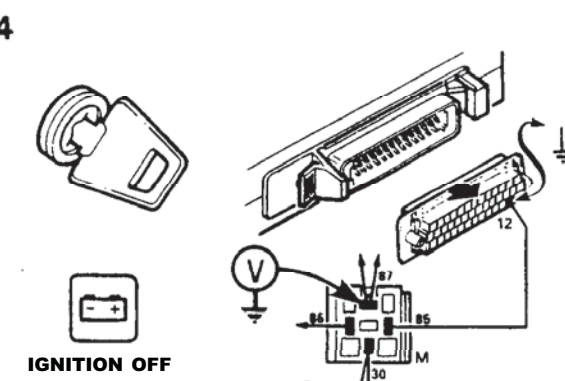
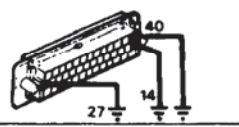
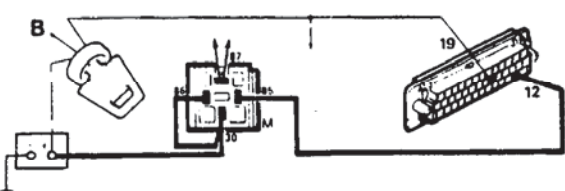

TEST PROCEDURE	RESULTS - Check cables and units shown in bold
<p>4. Fault Diagnosis Main relay circuits</p>	<p>A. Voltmeter reading of battery volts - Check:- If OK Suspect ECU</p>
<p>4</p>  <p>IGNITION OFF</p> <p>RR2630E</p>	<p>A</p>  <p>B</p> 

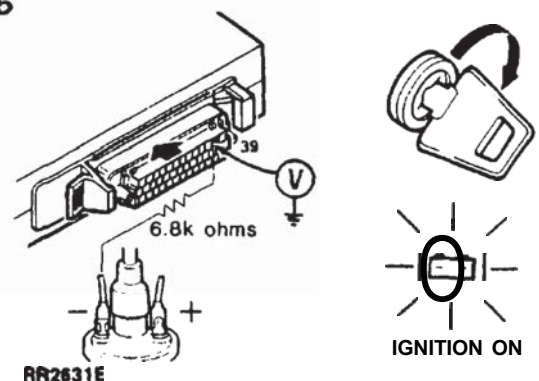
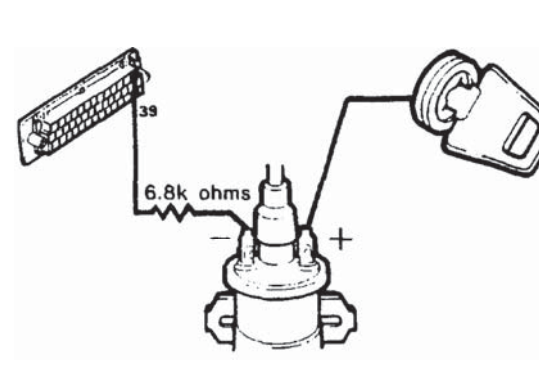
Continued

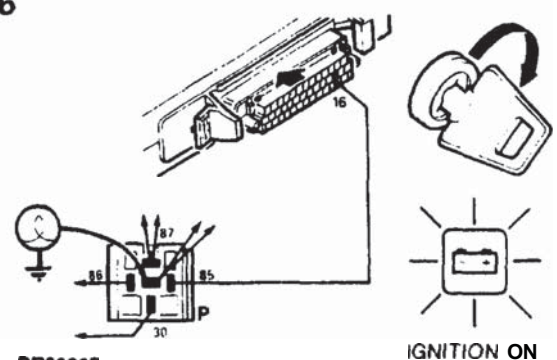
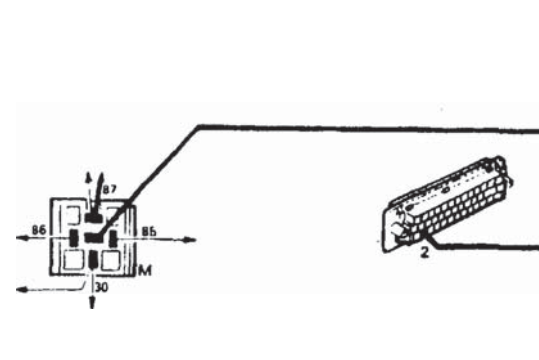
TEST PROCEDURE	RESULTS - Check cables and units shown in bold
<p>5. Check engine speed signal Cable and resistor</p>	<p>Voltmeter reading of 9.5 volts \pm 1 volt Proceed to Test 6</p> <p>Voltmeter reading of zero volts Check:-</p>
<p>5</p>  <p>RR2631E</p>	

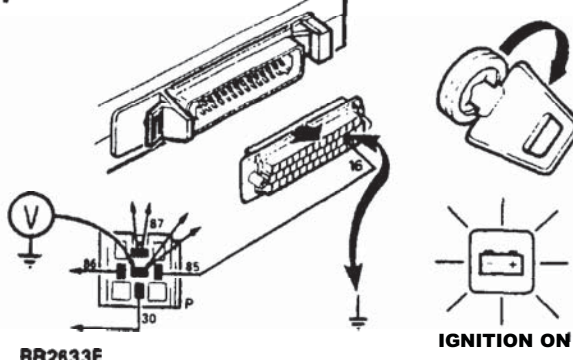
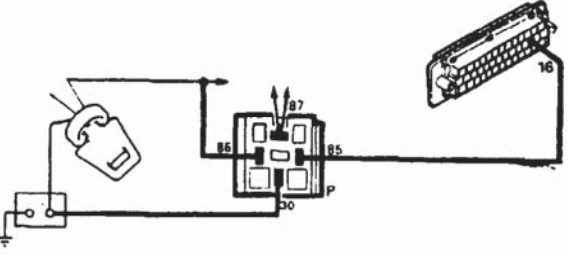
TESTPROCEDURE	RESULTS - Check cables and units shown in bold
<p>6. Check operation of pump relay</p>	<p>Test lamp will illuminate for approximately 1 second when ignition is switched on If O.K - Proceed to Test 8</p> <p>Lamp does not illuminate Check:- If OK proceed to Test 8</p>
<p>6</p>  <p>RR2632E</p>	

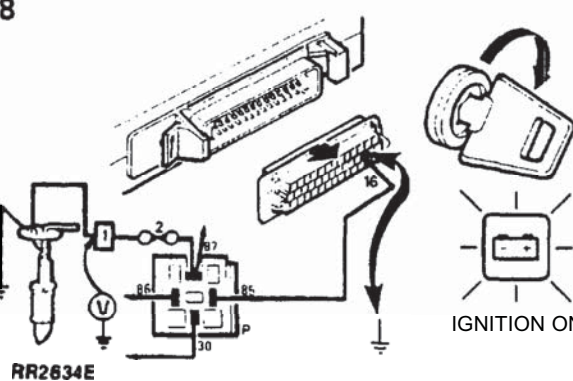
TEST PROCEDURE	RESULTS - Check cables and units shown in bold
<p>7. Fault diagnosis Pump relay circuits</p>	<p>Voltmeter reading of battery volts - Suspect ECU</p>
<p>7</p>  <p>RR2633E</p> <p>IGNITION ON</p>	<p>Voltmeter reading of zero volts Check:-</p> 

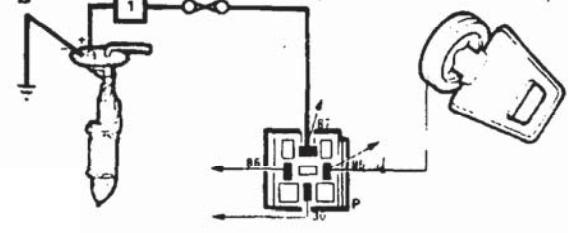
TEST PROCEDURE	RESULTS - Check cables and units shown in bold
<p>3. Check operation of Fuel pump</p> <p>NOTE: It is not possible to place the multi-meter probes directly onto the pump terminals. A link lead attached to the pump is accessible behind the rear left hand wheel located between the chassis and stowage area floor panel.</p> <p>KEY: 1. Inertia switch 2. Fuse 18</p>	<p>Voltmeter reading of battery volts - Pump operating - Proceed to Test 10</p> <p>(A) Voltmeter reading of battery volts - Pump not operating Check:-</p> <p>(B) Voltmeter reading of zero volts Check:-</p>
<p>8</p>  <p>RR2634E</p> <p>IGNITION ON</p>	<p>A</p>  <p>B</p> 

Continued

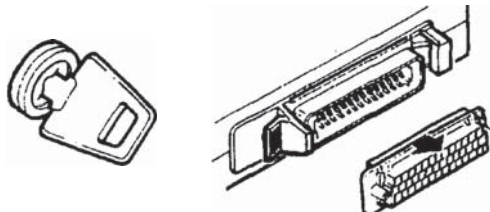
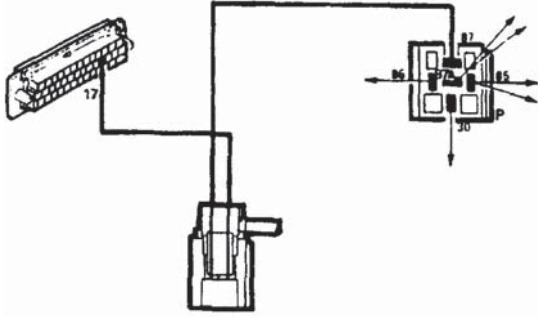
TEST PROCEDURE	RESULTS - Check cables and units shown in bold
<p>9. Check purge valve. Part 1 - seating</p> <ol style="list-style-type: none"> 1. Disconnect pipe from purge valve to plenum (at plenum) 2. Connect vacuum pump to pipe to purge valve 3. Apply vacuum of 2.5 in/Hg 	<p>Vacuum should hold for 2.5 minutes If vacuum correct proceed to test 10</p> <p>If vacuum incorrect check:</p>
<p>3</p>  <p>0 IGNITION OFF</p> <p>RR2612E</p>	

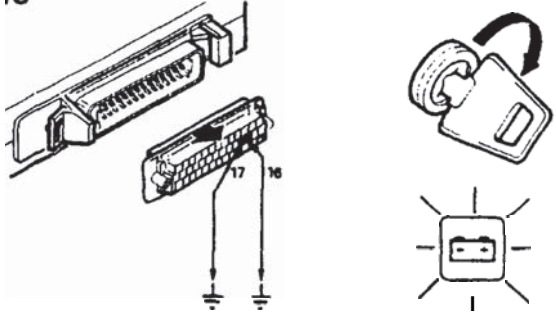
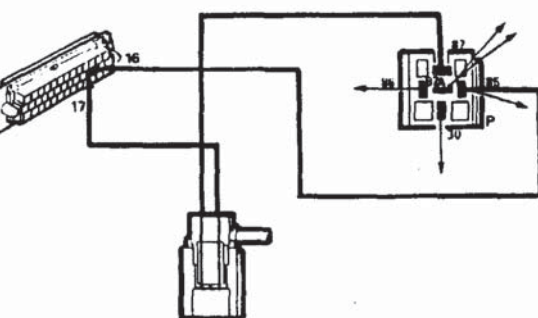
TEST PROCEDURE	RESULTS - Check cables and units shown in bold
<p>10. Check purge valve. Part 2 - operation</p> <ol style="list-style-type: none"> 1. Apply vacuum = 2.5 in/Hg, switch ignition on 2. Connect pins 16 and 17 to earth to energise pump relay. 	<p>Vacuum should be released If OK proceed to test 11</p> <p>If vacuum not released check:</p>
<p>10</p>  <p>IGNITION ON</p> <p>RR2613E</p>	

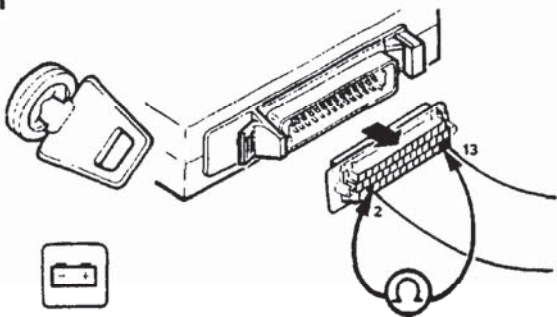
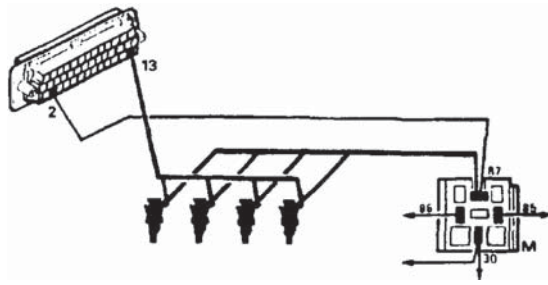
TEST PROCEDURE	RESULTS - Check cables and units shown in bold
<p>11. Check injectors, Injector circuit</p> <p>(Pin 13 left bank 'A' injectors 1,3,5,7).</p>	<p>Ohm-meter reading of 4-4.5 Ohms - Proceed to Test 12</p> <p>Ohm-meter reading of 5-6 Ohms - Suspect 1 injector</p> <p>Ohm-meter reading of 8-9 Ohms - Suspect 2 injectors</p> <p>Ohm-meter reading of 16-17 Ohms - Suspect 3 injectors</p> <p>Check for open circuit injector(s) or wiring faults.</p> <p>Ohm-meter reading of Infinity Check:</p>
<p>11</p>  <p>IGNITION OFF</p> <p>RR2635E</p>	

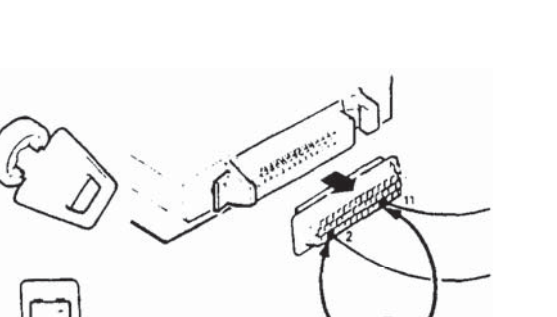
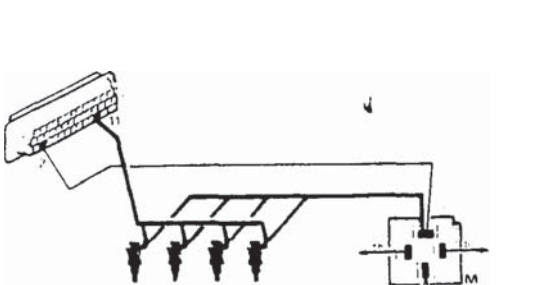
TEST PROCEDURE	RESULTS - Check cables and units shown in bold
<p>12. Check injectors, Injector circuit</p> <p>(Pin 11 rightbank 'B' injectors 2,4,6,8)</p>	<p>Ohm-meter reading of 4-4.5 Ohms - Proceed to Test 13</p> <p>Ohm-meter reading of 5-6 Ohms - Suspect 1 injector</p> <p>Ohm-meter reading of 8-9 Ohms - Suspect 2 injectors</p> <p>Ohm-meter reading of 16-17 Ohms - Suspect 3 injectors</p> <p>Check for open circuit injector(s) or wiring faults.</p> <p>Ohm-meter reading of Infinity Check:</p>
<p>12</p>  <p>IGNITION OFF</p> <p>RR2636E</p>	

Continued

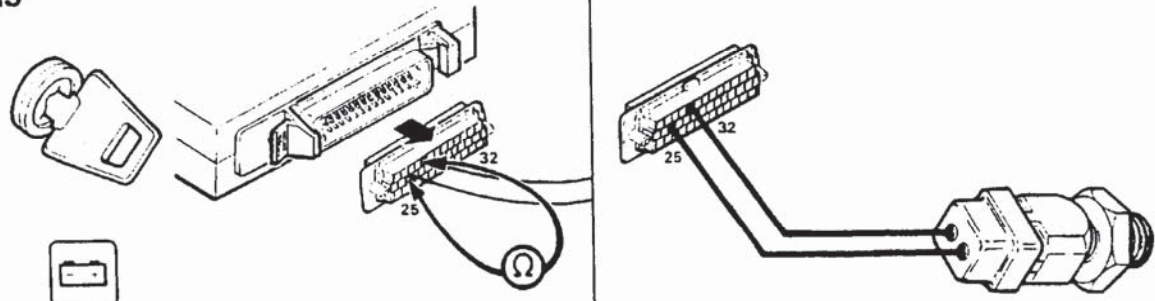
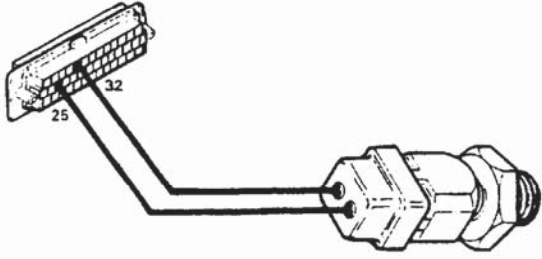
TEST PROCEDURE	RESULTS - Check cables and units shown in bold
<p>13. Check fuel temperature thermistor (sensor)</p>	<p>Correct reading-temperature to resistance - Proceed to Test 14 (Refer to Temperature Conversion Charts in Test 14)</p> <p>Incorrect Ohm-meter reading Check</p>
<p>13</p>  <p>IGNITION OFF</p> <p>RR2638E</p>	

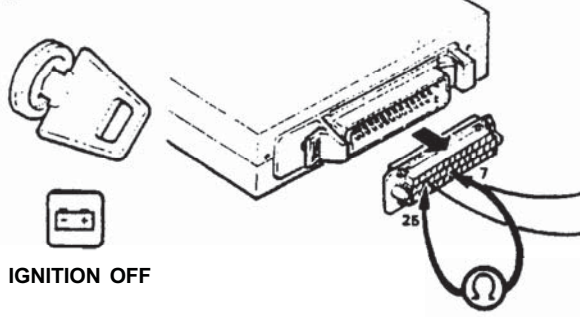
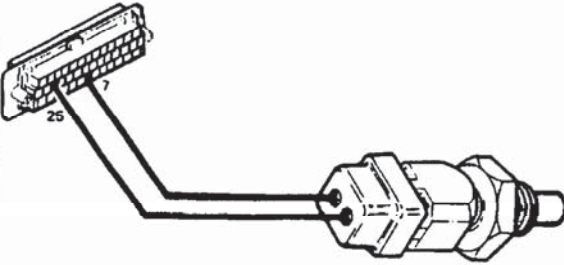
TEST PROCEDURE	RESULTS - Check cables and units shown in bold																											
<p>14. Check coolant temperature thermistor (sensor)</p>	<p>Correct reading-Temperature to resistance - Proceed to Test 15 (Refer to Temperature Conversion Chart below.</p> <table border="1" data-bbox="885 409 1437 682"> <thead> <tr> <th colspan="2">Fuel and Coolant Temperature</th> <th>Ohm-meter Reading Should be</th> </tr> <tr> <th>°C</th> <th>°F</th> <th>Ohms</th> </tr> </thead> <tbody> <tr> <td>-10°</td> <td>14°</td> <td>9100 - 9300</td> </tr> <tr> <td>0°</td> <td>32°</td> <td>5700 - 5900</td> </tr> <tr> <td>20°</td> <td>68°</td> <td>2400 - 2600</td> </tr> <tr> <td>40°</td> <td>104°</td> <td>1100 - 1300</td> </tr> <tr> <td>60°</td> <td>140°</td> <td>500 - 700</td> </tr> <tr> <td>80°</td> <td>176°</td> <td>300 - 400</td> </tr> <tr> <td>100°</td> <td>212°</td> <td>150 - 200</td> </tr> </tbody> </table> <p>Incorrect Ohm-meter reading Check:-</p>	Fuel and Coolant Temperature		Ohm-meter Reading Should be	°C	°F	Ohms	-10°	14°	9100 - 9300	0°	32°	5700 - 5900	20°	68°	2400 - 2600	40°	104°	1100 - 1300	60°	140°	500 - 700	80°	176°	300 - 400	100°	212°	150 - 200
Fuel and Coolant Temperature		Ohm-meter Reading Should be																										
°C	°F	Ohms																										
-10°	14°	9100 - 9300																										
0°	32°	5700 - 5900																										
20°	68°	2400 - 2600																										
40°	104°	1100 - 1300																										
60°	140°	500 - 700																										
80°	176°	300 - 400																										
100°	212°	150 - 200																										
<p>14</p>  <p>RR2637E</p>																												

Continued

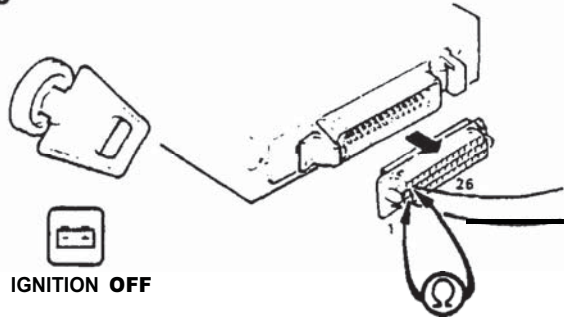
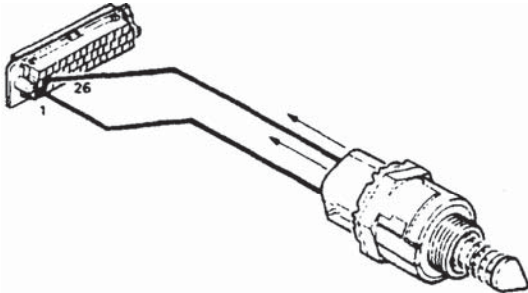
<p>MT PROCEDURE</p>	<p>RESULTS - Check cables and units shown in bold</p>
<p>15. Check air bypass valve - Part 1</p>	<p>Ohm-meter reading of 40-60 Ohms - Proceed to Test 16</p> <p>Incorrect reading Check:-</p>
<p>15</p>  <p>IGNITION OFF</p> <p>RR2639E</p>	

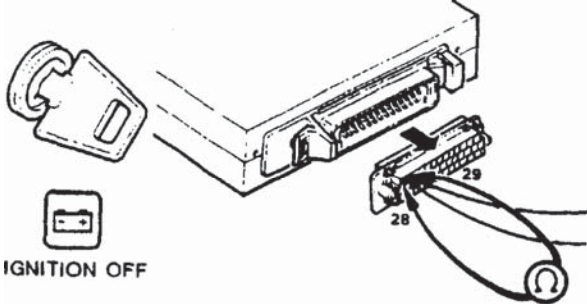
<p>TEST PROCEDURE</p>	<p>RESULTS - Check cables and units shown in bold</p>
<p>16. Check air bypass valve - Part 2</p>	<p>Ohm-meter reading of 40-60 Ohms - Proceed to Test 17</p> <p>Incorrect reading Check:-</p>
<p>16</p>  <p>IGNITION OFF</p> <p>IR2640E</p>	

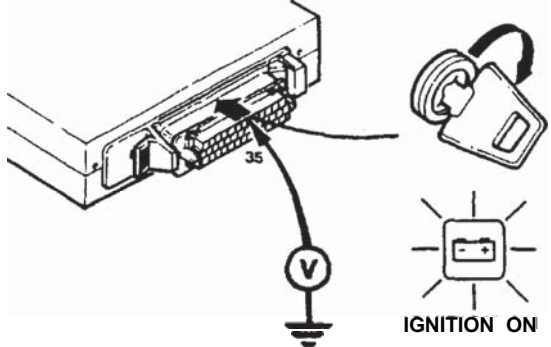
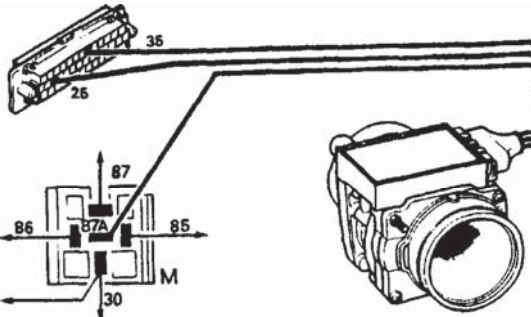
TEST PROCEDURE	RESULTS - Check cables and units shown in bold
<p>IS. Check output of Airflow sensor</p>	<p>Voltmeter reading of 0.2-0.7 volts- Proceed to Test 20</p> <p>Incorrect voltmeter reading Check:-</p>
 <p>IR2643E</p>	

PRECAUTION:

Depressurize the fuel system when fitting the fuel pressure gauge or disconnecting/replacing fuel system components.

CAUTION: Thoroughly clean the immediate area around the fuel filter and hose connections before disconnecting the fuel feed line from the filter. Failure to do so could cause foreign matter to be present in the fuel system which would be detrimental to the fuel system components.

WARNING: The spillage of fuel from the fuel filter is unavoidable when disconnecting the fuel feed line, ensure that all necessary precautions are taken to prevent fire and explosion due to fuel vapour and fuel seepage,

DEPRESSURIZING PROCEDURE

- a) Ignition off, pull pump relay off its terminal block.
- b) Crank engine for a few seconds - engine may fire and run until fuel pressure is reduced.
- c) Switch off the ignition.
- d) Connect fuel pressure gauge in the fuel supply line between the fuel rail and the fuel filter, adjacent to the filter (see Test 20).
- e) Reconnect the pump relay.

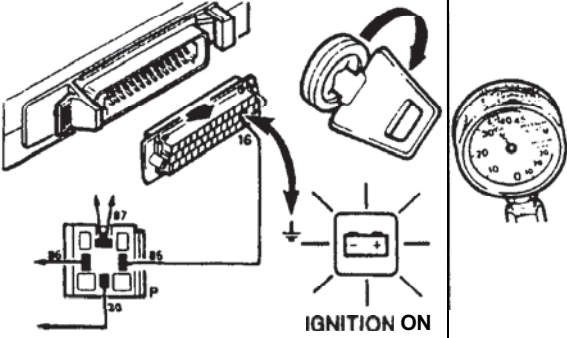
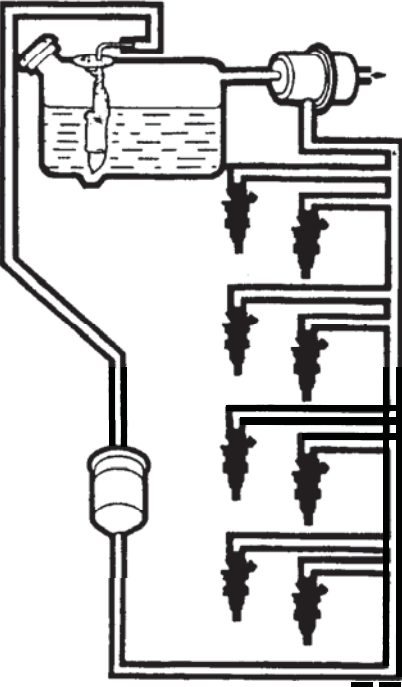
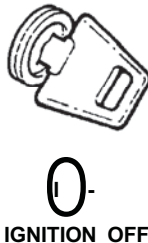
TEST PROCEDURE	RESULTS - Check cables and units shown in bold
<p>20. Check fuel system pressure Service tool 18G 1500</p> <p>NOTE: Insert the pressure gauge in the fuel feed line immediately after the fuel line filter. The filter is located beneath the right hand rear wheel arch attached to the chassis</p>	<p>(A) Expected reading 2,39-2,672 kgf/cm² (34.0-38.0 p.s.i.)</p> <p>(B) Pressure drop-max 0.7 kgf/cm² (10 p.s.i.) in one minute</p> <p>Proceed to Test 21</p>
<p>20</p> 	
 <p>RR2644E</p>	

Continued

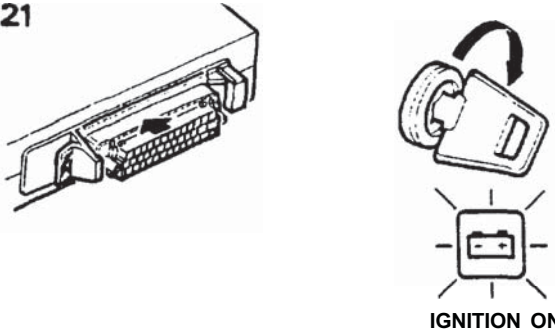
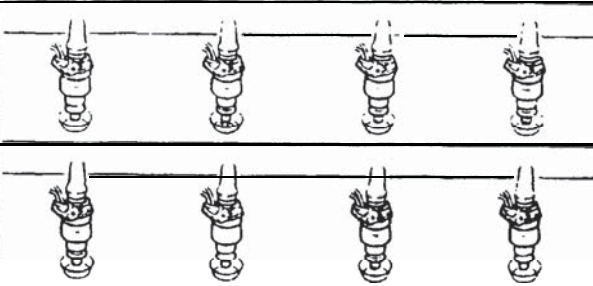
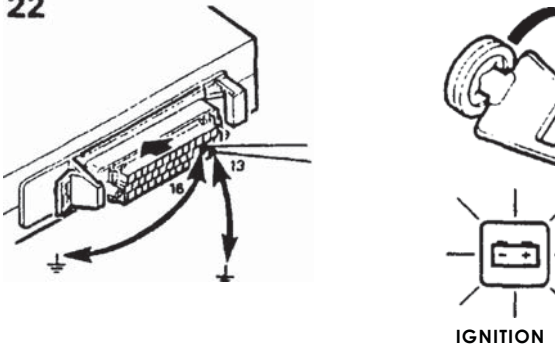
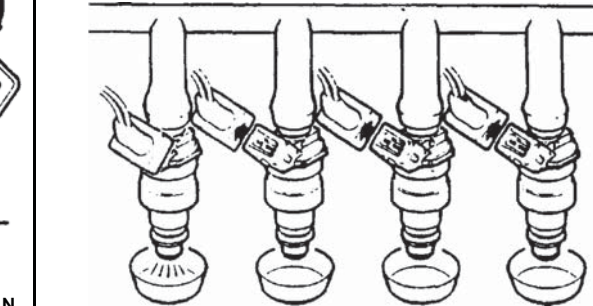
EST PROCEDURE	RESULTS - Check cables and units shown in bold
<p>11. Check for leaking injector</p> <p>NOTE: Before removing any of the injectors, remove and examine the spark plugs, check for consistent colouration of plugs. A leaking injector will result in the appropriate spark plug being 'sooted up'.</p> <p>Remove all injectors from manifold but do not disconnect from fuel rail</p>	<p>WARNING: Ensure that all necessary precautions are taken to prevent fire and explosion.</p> <p>Replace any injector which leaks more than 2 drops of fuel per minute.</p>
<p>21</p>  <p>RR2645E</p>	
'ESTPROCEDURE	RESULTS - Check cables and units shown in bold
<p>12. Check for injector operation Left bank 'A' injectors 1,3,5,7</p>	<p>WARNING: Ensure that all necessary precautions are taken to prevent fire and explosion.</p> <p>Repeat test for other injectors Replace any injector which does not operate.</p> <p>NOTE: Fuel flow is 160-175 cc (using white spirit) or 180-195 cc fusing petrol) (minimum) per minute per injector, at 2.54 kgf/cm² (36.25 psi) system pressure at 20°C ± 2°C</p>
<p>22</p>  <p>RR2646E</p>	

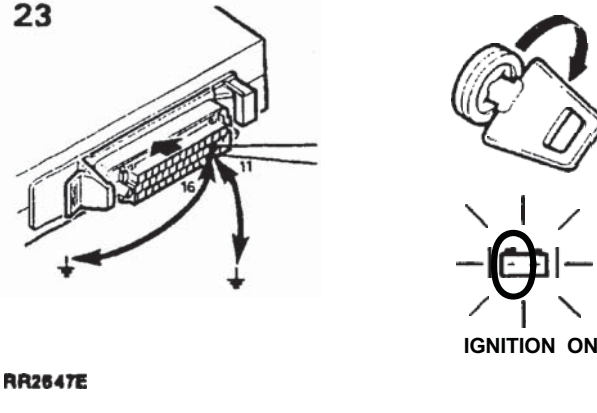
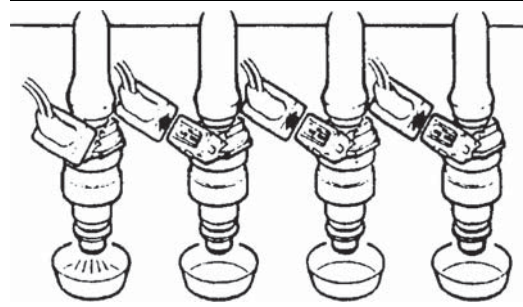
TEST PROCEDURE	RESULTS - Check cables and units shown in bold
<p>23. Right bank 'B' injectors 2,4,6,8</p>	<p>WARNING: Ensure that all necessary precautions are taken to prevent fire and explosion</p> <p>Repeat test for other injectors Replace any injector which does not operate</p> <p>NOTE: Fuel flow is 160-175 cc fusing mineral spirits) or 180-195 cc (using gasoline) (minimum) per minute per injector, at 2.54 kgf/cm² (36.25 psi) system pressure at 20°C ± 2°C</p>
<p>23</p>  <p>RR2647E</p>	

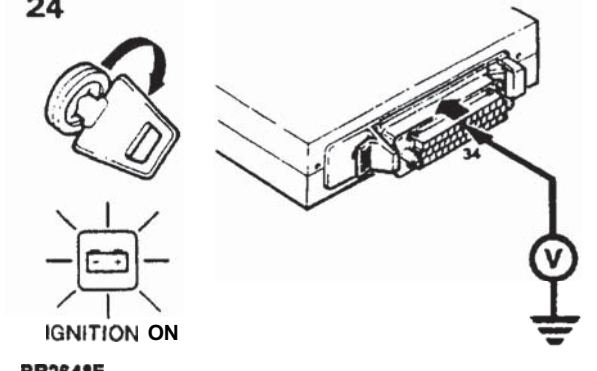
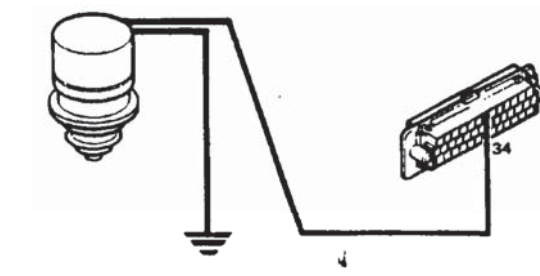
TEST PROCEDURE	RESULTS - Check cables and units shown in bold
<p>14. Check gear switch input</p>	<p>Voltmeter reading of zero volts- Neutral and park</p> <p>Voltmeter reading of 2.5-5.0 Volts -R.D.3.2.1 - Proceed to Test 25</p> <p>Incorrect reading Check:</p>
<p>24</p>  <p>RR2648E</p>	

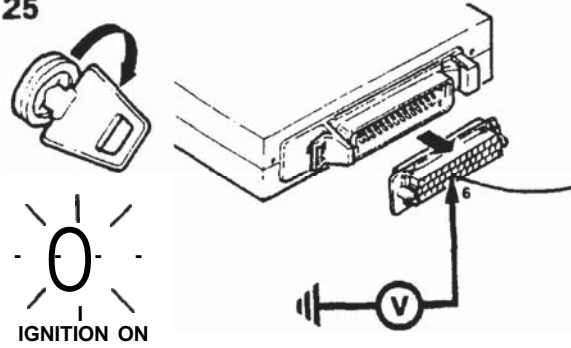
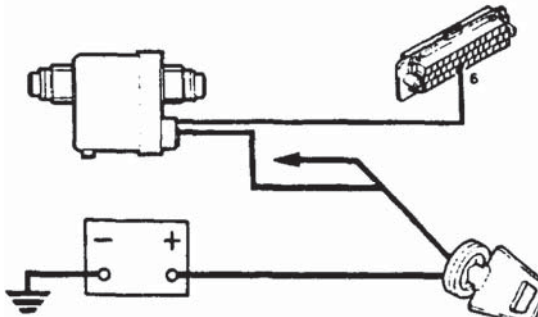
TEST PROCEDURE	RESULTS - Check cables and units shown in bold
<p>25. Check road speed input</p> <p>NOTE: Raise and rotate the left hand test road wheel slowly</p>	<p>Voltmeter reading of 0 to 12V fluctuating 6 times per revolution - Proceed to Test 26</p> <p>Incorrect reading Check:</p>
<p>25</p>  <p>IGNITION ON</p> <p>RR2649E</p>	

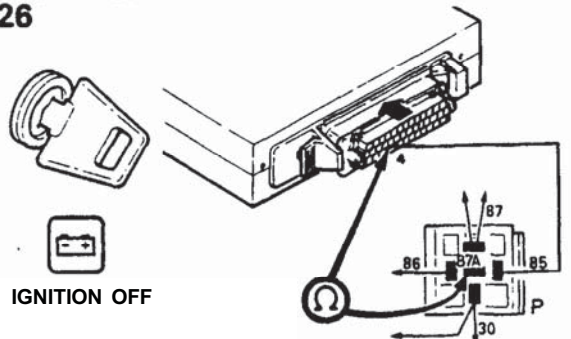
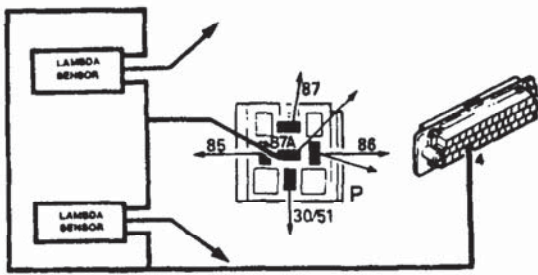
TEST PROCEDURE	RESULTS - Check cables and units shown in bold
<p>26. Check Lambda sensor heater coils</p> <p>VOTE: Remove pump relay from its connector</p>	<p>Ohm-meter reading of 2.5-6.0 Ohms</p> <p>Incorrect reading Check:</p>
<p>26</p>  <p>IGNITION OFF</p> <p>RR2650E</p>	

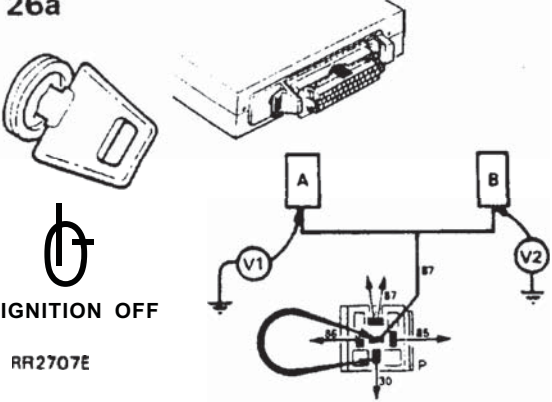
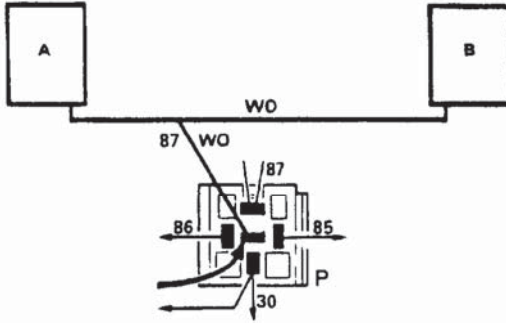
TEST PROCEDURE	RESULTS - Check cables and units shown in bold
<p>26a. Check Lambda sensor supply</p> <p>A. LH Lambda sensor B. RH Lambda sensor</p>	<p>Correct V1 and V2 - 12 volts Proceed to Test 26b</p> <p>Incorrect reading Check:</p>
<p>26a</p>  <p>IGNITION OFF</p> <p>RR2707E</p>	

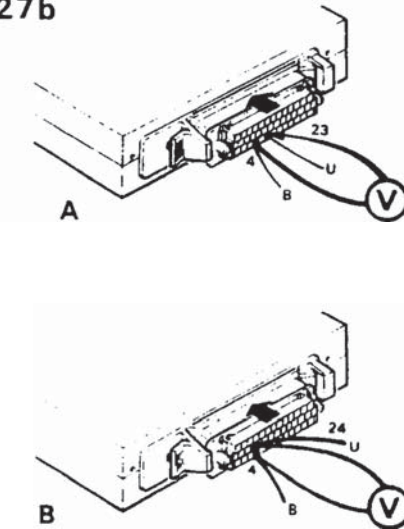
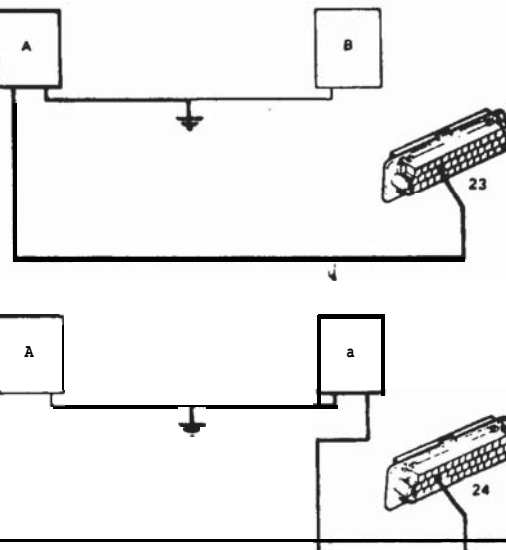
TEST PROCEDURE	RESULTS - Check cables and units shown in bold
<p>26b. Check Lambda sensor operation</p> <p>Note: Select 'P' in main gearbox and run engine at 1000 rev/min, normal operating temperature</p> <p>A. LH Lambda sensor B. RH Lambda sensor</p>	<p>Correct 0.50V - 1.00V fluctuating</p> <p>Incorrect 0.050 V - Check: Air leaks, faulty or contaminated injectors, low fuel pressure - if OK fit new Lambda sensor</p> <p>Incorrect 1.00V - Check: High fuel pressure, leaking injectors, saturated carbon canister - if OK fit new Lambda sensor.</p>
<p>27b</p>  <p>RR2708E</p>	

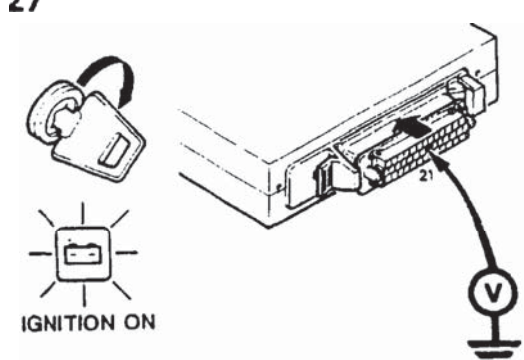
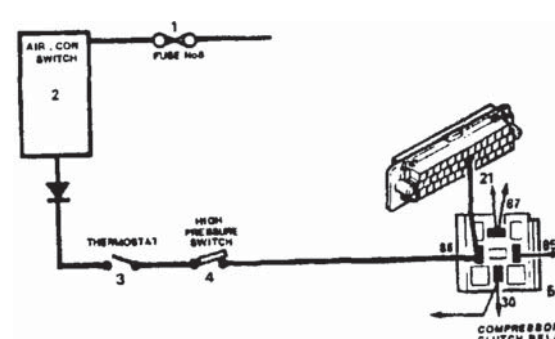
TEST PROCEDURE	RESULTS - Check cables and units shown in bold
<p>27. Check air conditioning thermostat input</p> <p>NOTE: Select air conditioning position and move thermostat switch to cold</p> <p>KEY:</p> <ol style="list-style-type: none"> 1. Fuse B 2. Air conditioning switch 3. Air conditioning thermostat 4. High pressure switch - air conditioning 5. Compressor clutch relay 	<p>Voltmeter reading of battery volts - Proceed to Test 28</p> <p>Incorrect reading Check:</p>
<p>27</p>  <p>IGNITION ON</p> <p>IR2651E</p>	 <p>COMPRESSION CLUTCH RELAY</p>

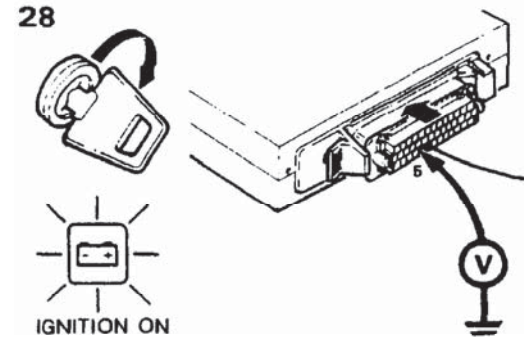
TEST PROCEDURE	RESULTS - Check cables and units shown in bold
<p>28. Check air conditioning input</p> <p>NOTE: Select heater fan speed I, II or III</p> <p>KEY:</p> <ol style="list-style-type: none"> 1. Fuse 6 2. Air conditioning switch 	<p>Voltmeter reading of battery volts - Proceed to Test 29</p> <p>Incorrect reading Check:</p>
<p>28</p>  <p>IGNITION ON</p> <p>RR2652E</p>	