

Lubrication system

The V8i full flow lubrication system uses a gear type oil pump which is driven from the front of the crankshaft. The oil pump gears are housed in the front cover and the pressure relief valve, warning light switch and filter are also fitted to the front cover.

Oil drawn through the centrally located steel gauze strainer in the sump, is pumped under pressure through oil cooler located in the lower half of the main coolant radiator. The cooled oil then passes through the filter, before being distributed from the main gallery via drillings, to the various components in the engine.

Lubrication to the thrust side of the cylinders is by oil grooves machined in each connecting rod big end joint face, which are timed to align with holes in the big end journals on the power and exhaust strokes.

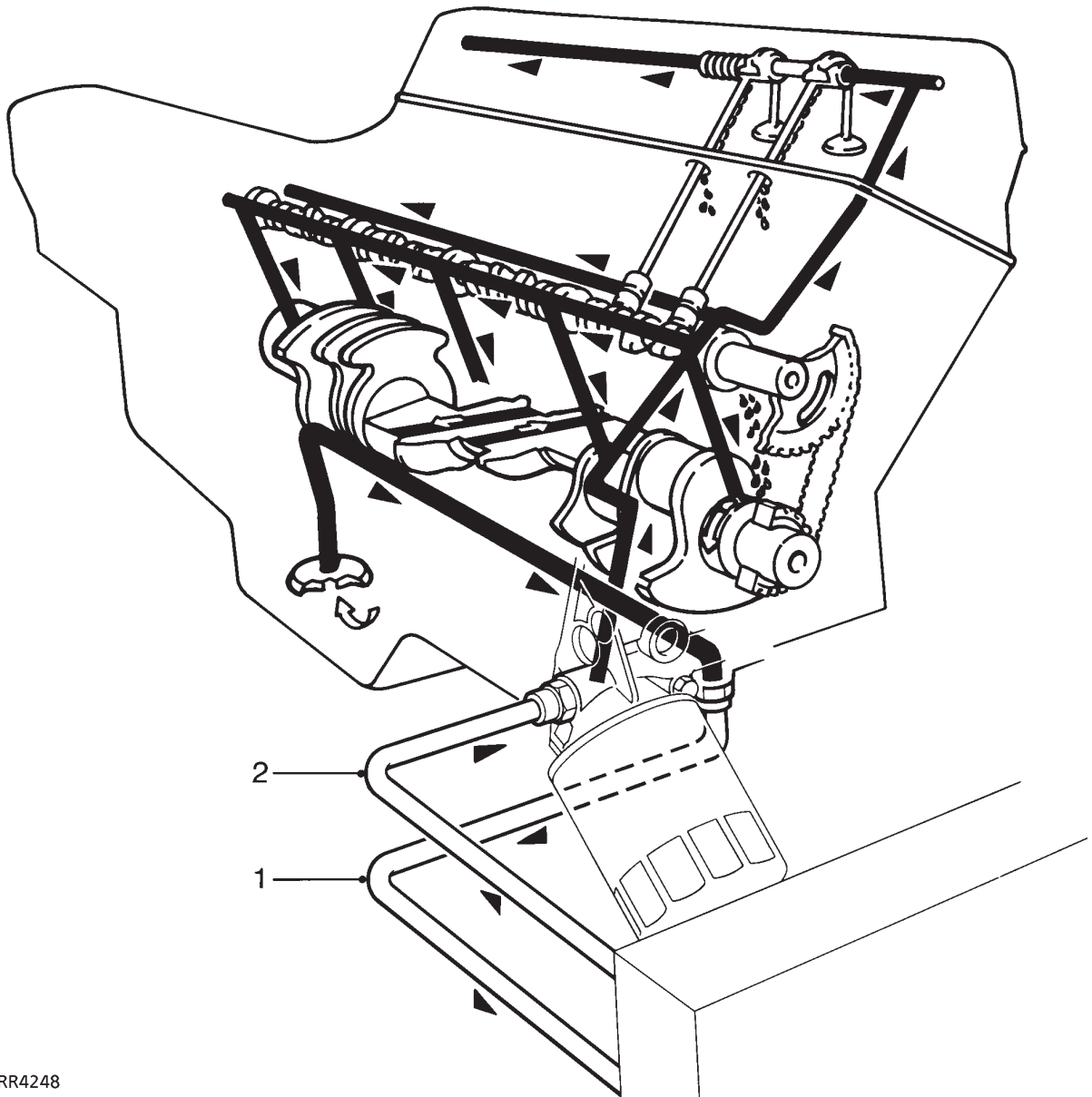

Lubrication system

1. Oil to cooler
2. Oil from cooler