

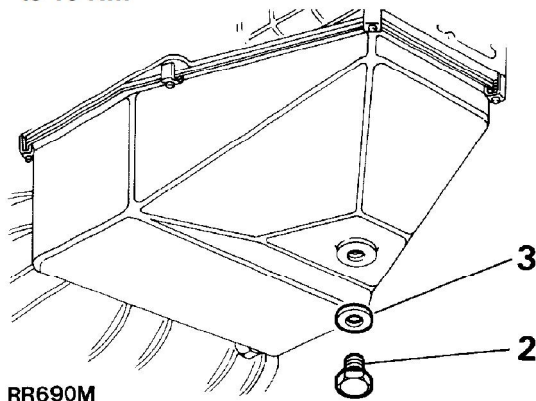

RENEW AUTOMATIC GEARBOX FLUID AND OIL SCREEN

1. Site vehicle on lift or level ground. Place container to drain gearbox fluid into. Disconnect battery negative lead.
2. Remove gearbox dipstick, located at rear of right hand rocker cover, to aid oil drainage. Release plug from bottom of sump and allow fluid to drain completely.
3. Refit plug using a new sealing washer. Tighten to **10 Nm**



6. Start and run engine. Apply footbrake, select position 1 then back to park. Check fluid level, this must be between the two marks on the dipstick.

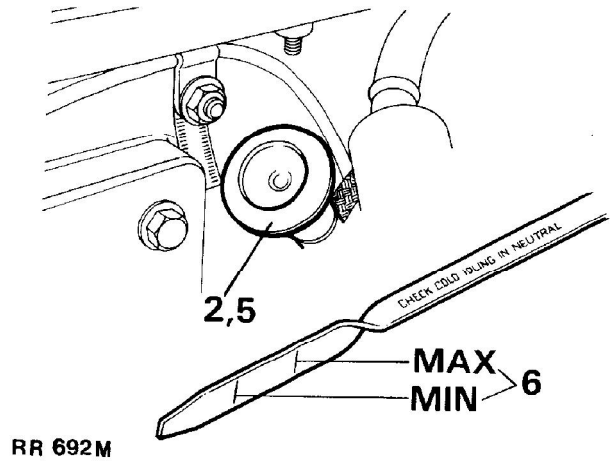

Oil screen replacement ZF automatic gearbox.
See *AUTOMATIC GEARBOX, Repair, Oil Screen*

Refill ZF Automatic Gearbox and Check Fluid Level.



NOTE: The fluid level must checked when fluid is cold and engine idling in park.

4. Ensure vehicle is on level ground.
5. Refill or top-up with correct quantity and grade of fluid. See **LUBRICANTS, FLUIDS AND CAPACITIES, Information, Recommended Lubricants and Fluids**