



## SUNROOF ELECTRIC MOTORS

Service repair no - 76.82.84/85

### FRONT MOTOR

#### Remove

1. Disconnect battery negative lead.
2. Ensure sunroof is in normally closed position



**NOTE:** If the electric motor has failed the sunroof can be closed manually using an allen key to turn motor spindle A.

3. Remove switch panel from stowage pocket panel
4. Remove interior lamp from stowage pocket panel
5. Remove alarm ultrasonic unit.
6. Unscrew ten fixings and remove stowage pocket from headlining.
7. Disconnect motor wiring multiplug.
8. Remove three screws and motor.

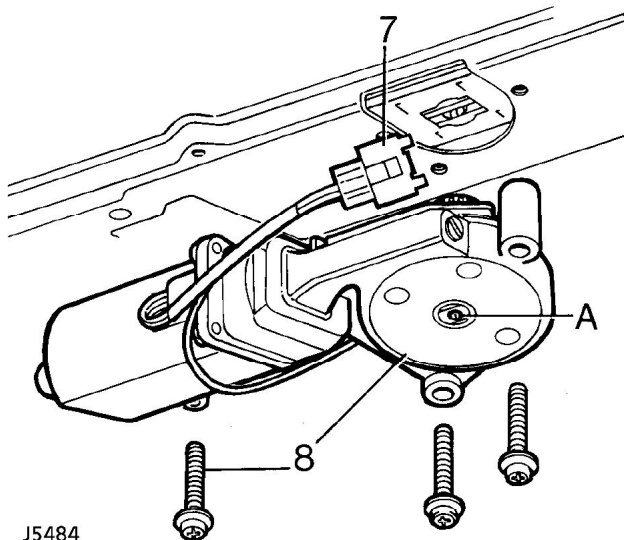

J5484

#### Refit

9. Reverse removal procedure.



**CAUTION:** Ensure the motor is aligned with fixing holes and the sunroof is in the normally closed position. DO NOT rotate the motor drive spindle in the rack - this may result in incorrect operation of the sunroof.

### REAR MOTOR

#### Remove

1. Disconnect battery negative lead.
2. Ensure sunroof is in normally closed position



**NOTE:** If the electric motor has failed the sunroof can be closed manually using an allen key to turn motor spindle.

3. Remove headlining. *See headlining.*
4. Disconnect motor wiring multiplug.
5. Remove three screws and motor.

#### Refit

6. Reverse removal procedure.



**CAUTION:** Ensure the motor is aligned with fixing holes and the sunroof is in the normally closed position. DO NOT rotate the motor drive spindle in the rack - this may result in incorrect operation of the sunroof.