

Secondary air injection system component layout

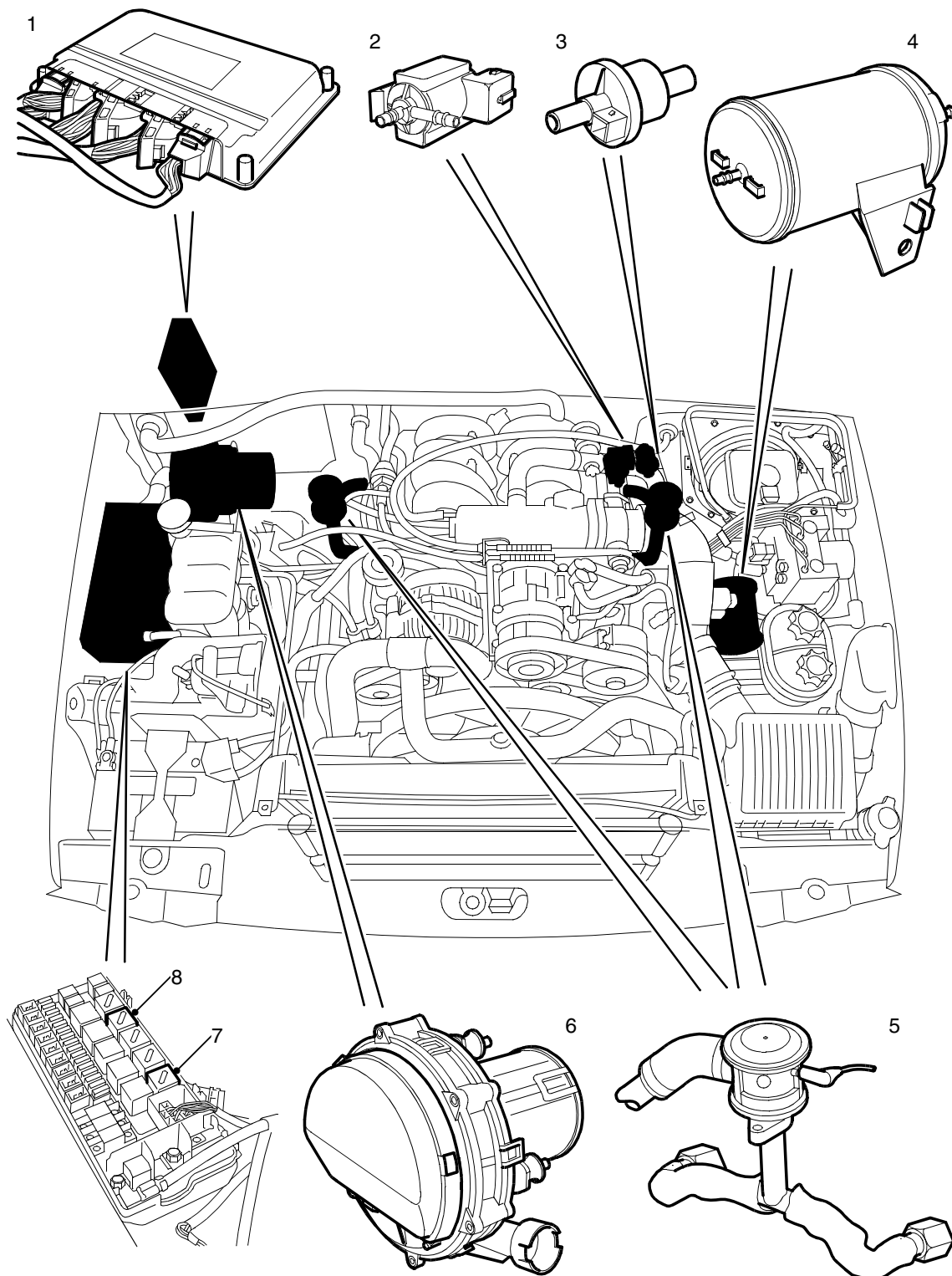

M17 0206



- 1 Engine Control Module (ECM)
- 2 SAI vacuum solenoid valve
- 3 Purge valve
- 4 Vacuum reservoir (up to 2003 model year location shown)
- 5 SAI control valve (2 off)
- 6 SAI pump
- 7 SAI pump relay
- 8 Main relay