

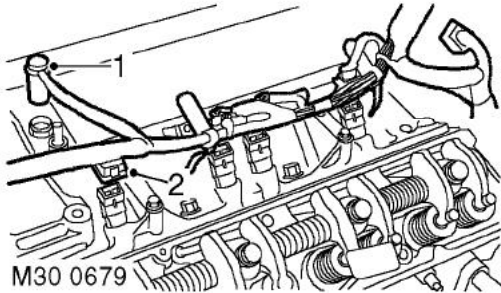

Gasket - inlet manifold

30.15.08.01

Disassembly



1. Disconnect multiplug from coolant thermistor.
2. Disconnect multiplugs from injectors; release injector harness from fuel rail and position aside.

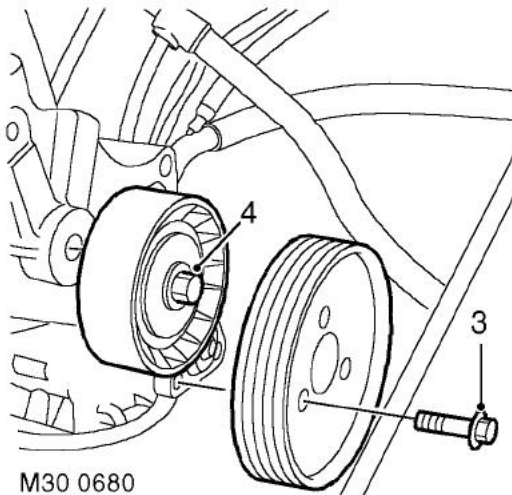

3. Remove 3 bolts securing PAS pump pulley and remove pulley.
4. Loosen bolt securing jockey pulley and remove pulley.

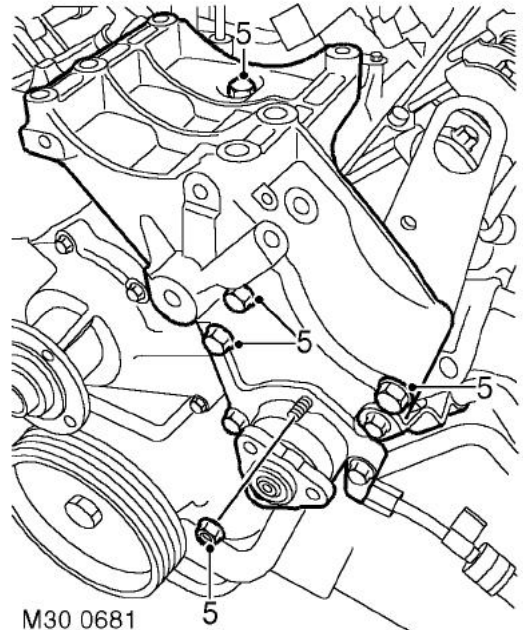

5. Remove 4 bolts and one nut securing auxiliary housing and remove housing.
6. Remove 2 nuts securing alternator cables and release the cables.

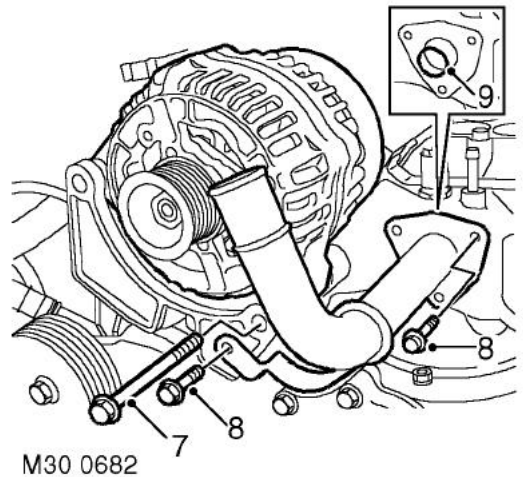

7. Remove two bolts securing alternator and remove alternator.
8. Remove 4 bolts securing coolant outlet elbow and remove outlet elbow.
9. Remove and discard 'O' ring.
10. Release ht leads from rocker covers.

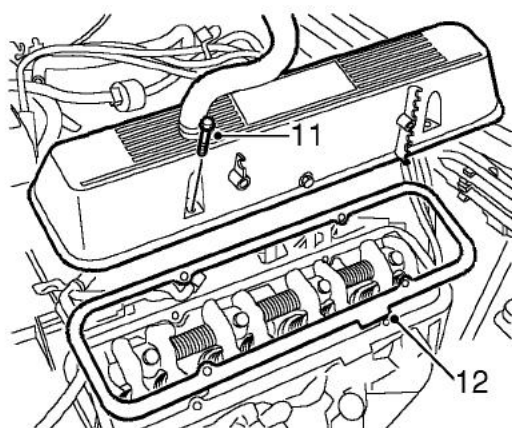
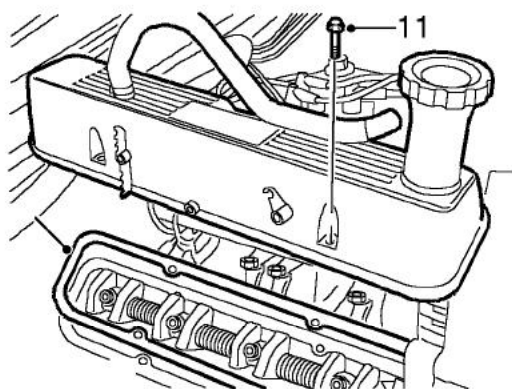

M30 0683

11. Noting fitted position of 4 long screws or multi-hex bolts, remove and discard 8 screws/bolts securing rocker covers; remove rocker covers.

CAUTION: Screws/bolts must be replaced with new 'patched' multi-hex bolts.

12. Remove and discard rocker cover gaskets.

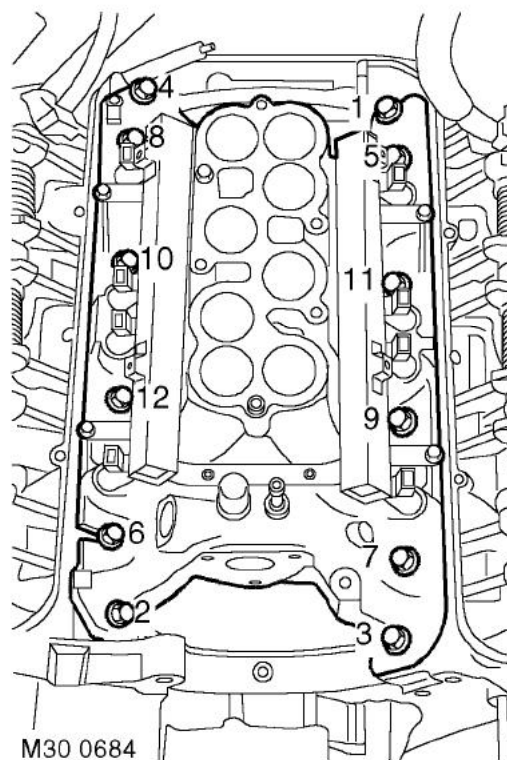

M30 0684

13. Using the sequence shown, remove 12 bolts securing the inlet manifold.
14. Remove inlet manifold assembly.

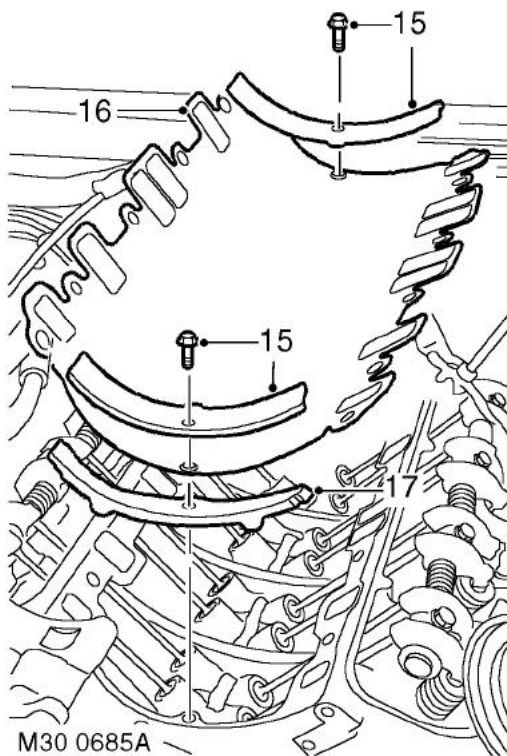

M30 0685A

15. Remove 2 bolts securing manifold gasket and collect gasket clamps.
16. Remove inlet manifold gasket.
17. Remove gasket seals.

Reassembly

1. Clean sealant from cylinder head and from notches in the cylinder block.
2. Clean mating faces of cylinder block, cylinder head and manifold.

CAUTION: Do not use a metal scraper or machined surfaces may be damaged.
3. Ensure bolt holes are clean and dry.
4. Apply sealant, Part No. STC 50550 to cylinder head and notches in cylinder block.
5. Fit new gasket seals, ensuring the ends engage correctly in notches.
6. Apply sealant, Part No. STC 50550 to gasket seals above the notches in the cylinder block.
7. Fit new manifold gasket, dry.
8. Position gasket clamps, fit and lightly tighten bolts.
9. Position inlet manifold assembly to cylinder head.

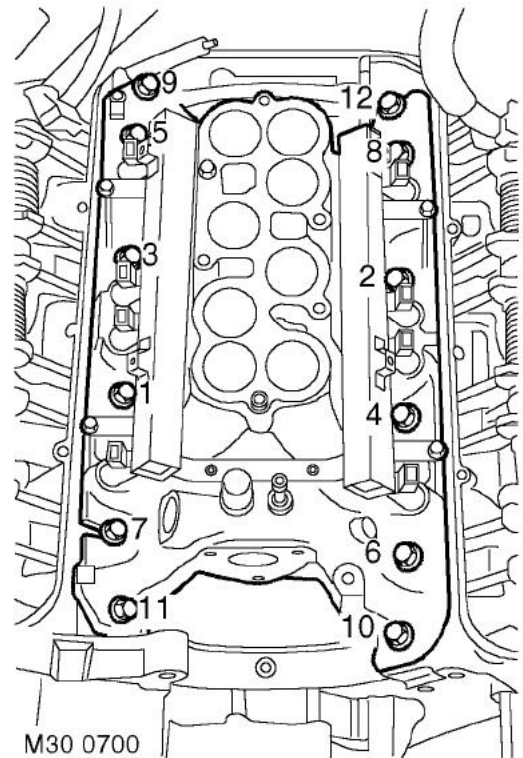

M30 0700

10. Fit manifold bolts and, working in the sequence illustrated, tighten as follows:
 - Initially, tighten bolts numbered 1, 4, 9 and 12 in numerical order to 5 Nm (4 lbf.ft).
 - Inlet manifold bolts - initial tighten = 10 Nm (8 lbf.ft).
 - Inlet manifold bolts - final tighten = 51 Nm (38 lbf.ft).
 - Tighten inlet manifold gasket clamp bolts to 18 Nm (14 lbf.ft).
 - Tighten inlet manifold bolts to 51 Nm (38 lbf.ft)
11. Clean mating faces of rocker cover and cylinder head, ensure that bolt holes are clean and dry.
12. Fit new rocker cover gaskets, dry, position rocker covers, ensuring gaskets are correctly located.
13. Fit new 'patched' multi-hex rocker cover bolts ensuring that short bolts are on sides of rocker covers nearest centre of engine.
14. Tighten bolts by diagonal selection to:
 - Stage 1 - 3 Nm (2.5 lbf.ft)
 - Stage 2 - 8 Nm (6 lbf.ft)
15. Ensure that outer rim of each gasket is correctly positioned around periphery of rocker cover.
16. Secure ht leads to rocker cover.
17. Clean coolant outlet elbow mating faces.
18. Lubricate and fit new 'O' ring to outlet pipe.
19. Position coolant outlet elbow, fit bolts and tighten to 22 Nm (17 lbf.ft).
20. Position alternator, fit mounting bolts and tighten to 45 Nm (34 lbf.ft).

ENGINE - V8

21. Position alternator cables and tighten terminal B+ to 18 Nm (13 lbf.ft) and terminal D+ to 5 Nm (3.5 lbf.ft).
22. Position auxiliary housing, fit bolts and tighten to 40 Nm (30 lbf.ft). Fit nut and tighten to 22 Nm (17 lbf.ft).
23. Clean jockey pulley mating faces.
24. Position jockey pulley and tighten bolt to 50 Nm (37 lbf.ft).
25. Clean PAS pump pulley mating faces.
26. Position PAS pump pulley, fit bolts and tighten to 22 Nm (17 lbf.ft).
27. Secure injector harness and connect injector multiplugs.
28. Connect multiplug to coolant thermistor.

Gasket - exhaust manifold

30.15.12.01

Disassembly

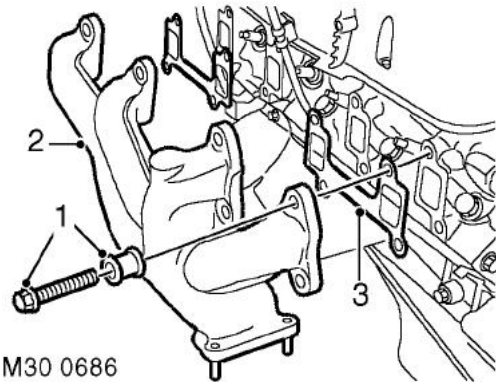

1. Remove 8 bolts securing exhaust manifold and collect spacers. Discard the bolts.
2. Remove exhaust manifold.
3. Remove 2 manifold gaskets and discard.

Reassembly

1. Clean exhaust manifold and cylinder head mating face.
CAUTION: Do not use a metal scraper or machined surfaces may be damaged.
2. Fit new gaskets, dry, fit exhaust manifold.
CAUTION: Ensure that link bar on gasket is positioned below spark plugs.

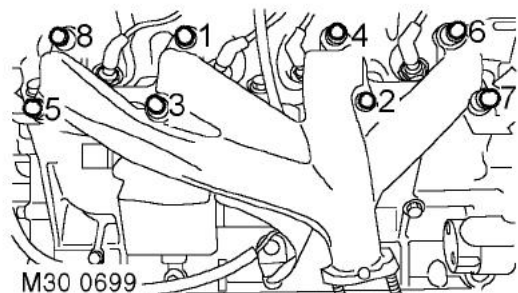

LH bank illustrated

3. Fit spacers to new manifold bolts and, working in the sequence illustrated, initially tighten bolts to 15 Nm (11 lbf.ft), then finally tighten to 38 Nm (28 lbf.ft).