



Cylinder head - overhaul

12.29.19.01

Disassembly

1. Remove cylinder head gasket.
 **ENGINE - V8, OVERHAUL, Gasket - cylinder head.**
2. Loosen screw on tool LRT-12-034.

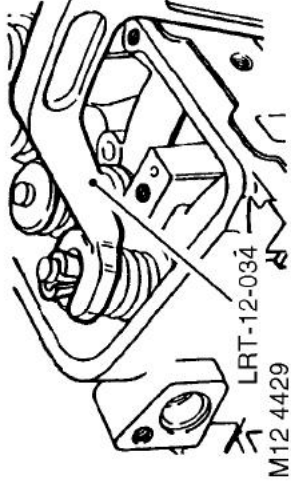

3. Fit tool LRT-12-034 to valve and tighten screw to compress valve spring sufficiently to release collets from valve spring cap.

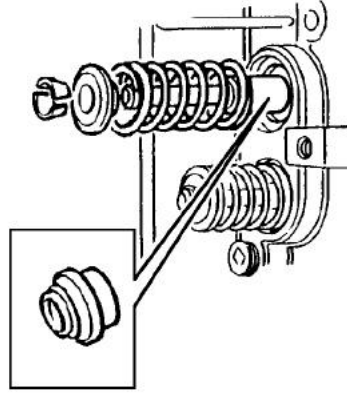

4. Remove 2 collets and release valve spring compressor.
5. Remove valve spring cap and valve spring.
6. Remove valve from cylinder head.
7. Remove and discard valve stem oil seal.
8. Repeat above operations for remaining valves.
9. Keep valves, springs, caps and collets in their fitted order.

Inspect

1. Clean mating faces of cylinder block and head using suitable gasket removal spray and a plastic scraper, ensure that bolt holes in block are clean and dry.
CAUTION: Do not use a metal scraper or machined surfaces may be damaged.
2. Clean cylinder head, valve springs, valves and inlet valve guide bores. Ensure all loose particles of carbon are removed on completion.
3. **Models with SAI:** Using a 5/8 in x 20 TPI (threads per inch) UNF tap having a class 2A thread, remove deposits from secondary air injection adapter tappings in cylinder head.
CAUTION: Ensure that tap used has 20 TPI.

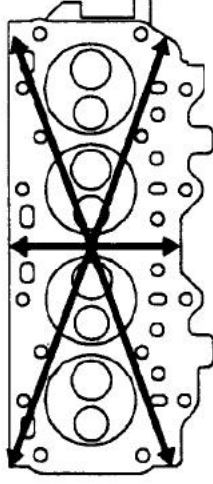

4. Check head and block faces for warping and pitting. Maximum warp = 0.05 mm (0.002 in).

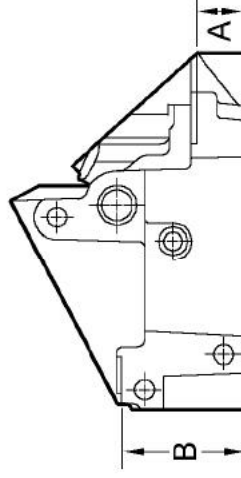
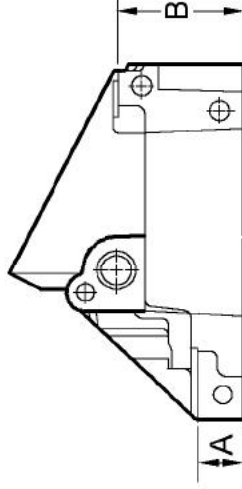

5. Check cylinder head height at each end of head. Renew a head which is outside limits.
 a 22.94 mm (0.903 in) - New
 b 62.56 mm (2.463 in) - New

ENGINE - V8

6. Cylinder head can be refaced to 0.50 mm (0.02 in) max. below head height.

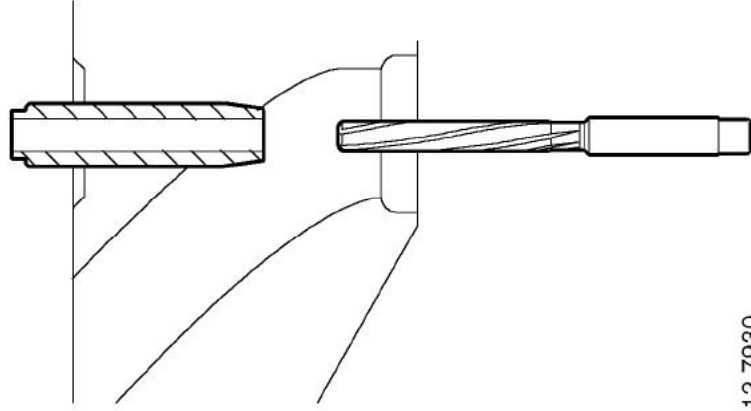

M12 7930

7. Remove carbon deposits from exhaust valve guide using a 8.70 mm (0.34 in) diameter reamer inserted from combustion face side of cylinder head.

NOTE: Modified inlet valves, exhaust valves and valve guides were fitted to 4.0 litre engines from the following engine numbers: 55D 05678A; 56D 50788A and 97D 05505A and are fitted to all 4.6 litre engines.

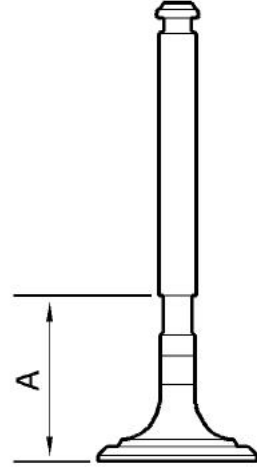

M12 7488

8. Modified inlet valves may be identified by measuring the distance 'A' from the valve head face to the top of the undercut on the valve stem:
- Early valves = 29.5 to 30.5 mm (1.16 to 1.20 in)
 - Later valves = 32.5 to 33.5 mm (1.28 to 1.32 in)

9. Modified exhaust valves may be identified as follows:

- Early valves 'A' – Chrome finish
- Later valves 'B' – Black nitrided finish

10. Modified valve guides are 5 mm (0.211 in) shorter than the early type, the overall length is now 57 mm (2.24 in); the reduction in length being the distance the guide protrudes into the combustion chamber side of the cylinder head.

NOTE: The modified valves and guides may be fitted to 4.0 litre engines prior to the above numbers in cylinder sets. Early type valves will continue to be supplied for early 4.0 litre engines but if valve guides are found to be worn, the later valves and guides must be fitted.

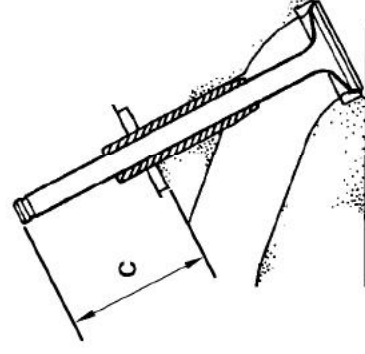
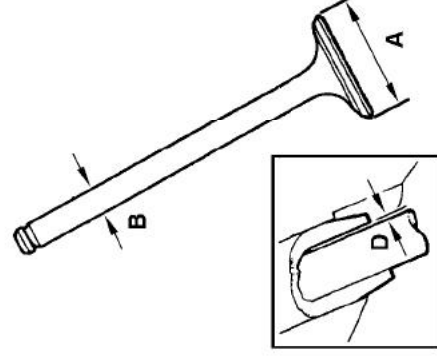

M12 7460



11. Check the following valve dimensions. Renew valves as necessary.

- Valve head diameter 'A': Inlet = 39.75 to 40.00 mm (1.56 to 1.57 in).
- Valve head diameter 'A': Exhaust = 34.23 to 34.48 mm (1.35 to 1.36 in).
- Valve stem diameter 'B': Inlet = 8.664 to 8.679 mm (0.341 to 0.342 in).
- Valve stem diameter 'B': Exhaust – 4.0 litre engines up to engine nos. 55D 05677A; 56D 50787A and 97D 05504A = 8.651 to 8.666 mm (0.340 to 0.341 in).
- Valve stem diameter 'B': Exhaust – 4.0 litre engines from engine nos. 55D 05678A; 56D 50788A and 97D 05505A and all 4.6 litre engines = 8.641 to 8.656 mm (0.340 to 0.341 in)

12. Check installed height of valve.

- Valve installed height, end of valve to base of spring seat, 'C' = 44.163 to 45.288 mm (1.741 to 1.802 in).

13. Check condition of valve springs. **Valve springs must be replaced as a complete set.**

- Valve spring free length = 48.30 mm (1.90 in).
- Valve spring fitted length = 40.40 mm (1.59 in).
- Spring load - valve closed = 339 ± 10 N (76 ± 2.25 lbf).
- Spring load - valve open = 736 ± 10 N (166 ± 2.25 lbf).

14. Check valve stem to guide clearance using the following procedures:

15. Insert each valve into its respective guide.

16. Extend valve head approximately 13 mm (0.6 in) out of valve seat and position a DTI gauge to rear of valve head.

17. Move valve towards front of cylinder head and zero DTI gauge ensuring that stylus of gauge remains in contact with valve head.

18. Move valve towards rear of cylinder head and record gauge reading to give valve stem to guide clearance.

- Valve stem to guide clearance 'D': Inlet = 0.025 to 0.066 mm (0.001 to 0.002 in).
- Valve stem to guide clearance 'D': Exhaust – 4.0 litre engines up to engine nos. 55D 05677A; 56D 50787A; 97D 05504A = 0.038 to 0.078 mm (0.0015 to 0.003 in).
- Valve stem to guide clearance 'D': Exhaust – 4.0 litre engines from engine nos. 55D 05678A; 56D 50788A; 97D 05505A and all 4.6 litre engines = 0.048 to 0.088 mm (0.0019 to 0.0035 in).

19. Renew valve guides as necessary.

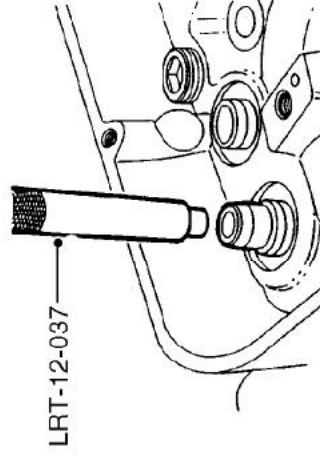

M12 4434

20. Using valve guide remover tool **LRT-12-037** press valve guide into combustion face side of cylinder head.

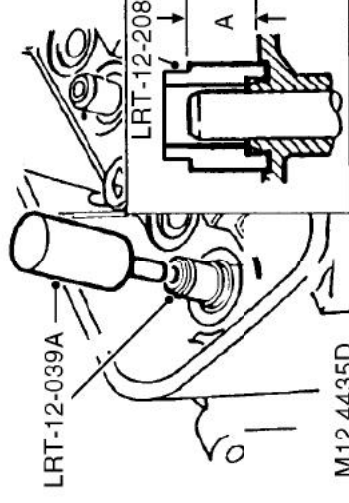

M12 4435D

21. Lubricate new valve guide with engine oil and with tapered portion of guide leading, insert guide from valve spring side of head.

Note: Service valve guides are 0.025 mm (0.001 in) oversize on outside diameter to ensure an interference fit.

22. Fully fit guide using tool **LRT-12-039A** and distance piece tool **LRT-12-208**

- Valve guide installed height 'A' = 15.00 mm (0.590 in).

23. Ream valve guide to 8.70 mm (0.342 in).

Note: Service valve guides are supplied with an internal diameter of 8.1 mm 0.025 mm (0.319 in).

24. Position cylinder head stands and mount cylinder head on stands.

25. Check valve seat insert for pitting, burning, cracks and wear. Replace as necessary.

Service valve seat inserts are available 0.025 mm (0.001 in) oversize on outside diameter to ensure interference fit.

ENGINE - V8

26. Remove worn valve seat.

CAUTION: Take care not to damage the counterbore in the cylinder head when removing valve seats.

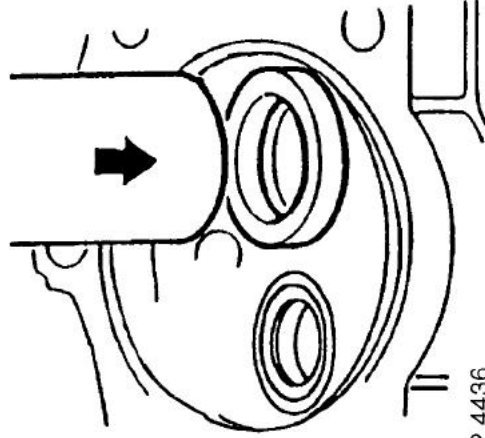

M12 4436

27. Heat cylinder head evenly to approximately 120° C (250°F).

WARNING: Handle the hot cylinder head with care.

28. Using a suitable mandrel, press new insert fully into counterbore.

29. Allow cylinder head to air cool.

CAUTION: Renew worn valve guides and/or valve seats before lapping the valves.

30. Recut valve seat in head and lap in valves using fine paste.

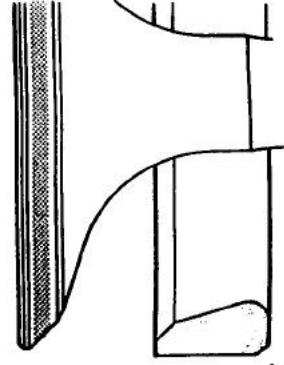

M12 4437

31. Coat valve with a small quantity of engineer's blue, insert valve and press into position several times without rotating. Seating position should be in centre of valve face.

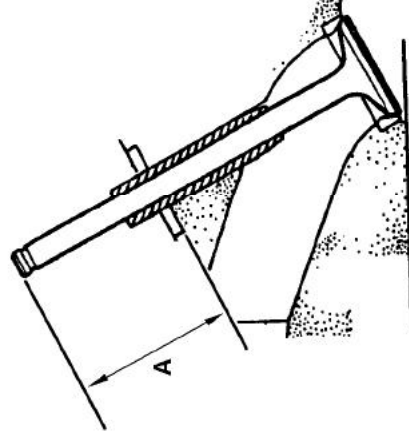

M12 7461

32. Check valve installed height if valve seats have been refaced or renewed.

- Valve installed height, end of valve to base of spring seat, 'A' = 44.16 to 45.29 mm (1.74 to 1.80 in).

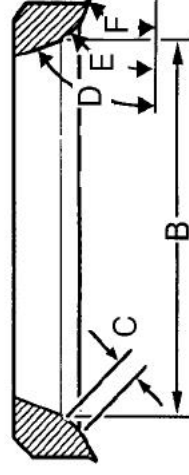
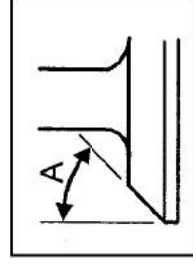

33. Reface valves as necessary. If a valve has to be ground to a knife-edge to obtain a true seat, renew valve.

34. Cut valve seats using suitable cutters:

- Valve seat angle 'A' = 45°.
- Valve seat insert diameter 'B' Inlet = 36.83 mm (1.45 in).
- Valve seat insert diameter 'B' Exhaust = 31.50 mm (1.24 in).
- Seating width 'C' - Inlet = 0.89 to 1.4 mm (0.035 to 0.055 in).
- Seating width 'C' - Exhaust = 1.32 to 1.83 mm (0.052 to 0.072 in).
- Angle 'D' = 70°.
- Angle 'E' = 46° to 46° 25'.
- Angle 'F' = 20°.

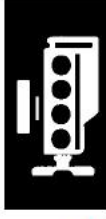

35. Check that cutter blades are adjusted so that middle of blade contacts area of material to be cut. Use light pressure and only remove the minimum of material necessary.
36. Clean valve seat and valve.

Reassembly

1. Clean spring caps, collets and valve springs.
2. Lubricate new valve stem oil seal with clean engine oil and fit seal.
3. Lubricate valve with clean engine oil and fit valve.

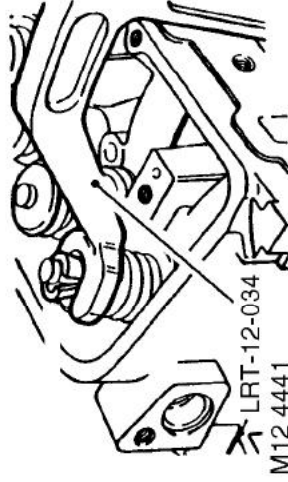



4. Fit spring and cap, compress spring using tool **LRT-12-034** and fit collets.
5. Release valve spring and remove tool **LRT-12-034**.
6. Fit cylinder head gasket.
 **ENGINE - V8, OVERHAUL, Gasket - cylinder head.**

Piston assemblies

12.17.02.01

Disassembly

1. Remove cylinder head.
 **ENGINE - V8, OVERHAUL, Gasket - cylinder head.**
2. Remove oil pick-up strainer.
 **ENGINE - V8, OVERHAUL, Strainer - oil pick-up.**

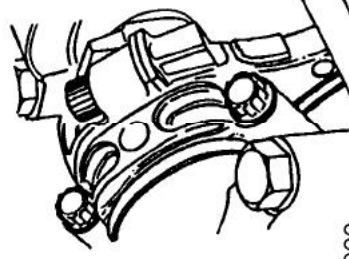

M12 4399

3. Suitably identify each connecting rod and piston assembly to its respective cylinder bore.
4. Remove 2 bolts securing each connecting rod bearing cap.
5. Remove connecting rod bearing cap and collect connecting rod bearings.
6. Remove ridge of carbon from top of cylinder bores.
7. Carefully push each piston assembly from the top of the cylinder.
CAUTION: Ensure that connecting rods do not contact cylinder bores.
8. Refit bearing cap onto connecting rod, lightly tighten dowel bolts.
9. Suitably identify each piston to its respective connecting rod.