

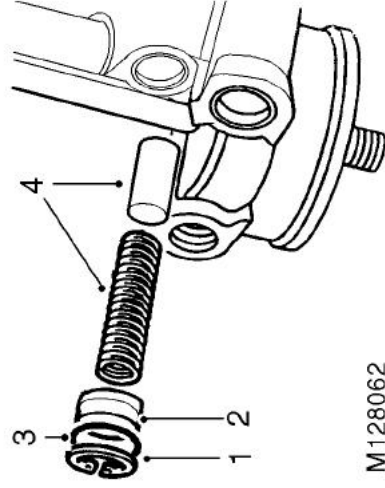

ENGINE

Oil pressure by-pass valve - remove



M128062

1. Remove circlip.
2. Remove by-pass valve plug.
3. Remove and discard 'O' ring from plug.
4. Remove by-pass valve spring and plunger.
5. Check plunger and bore of by-pass valve in oil pump body for scoring and corrosion.



NOTE: Light corrosion may be removed using grade 600 emery cloth soaked in oil.

Oil pressure relief valve - if fitted - remove

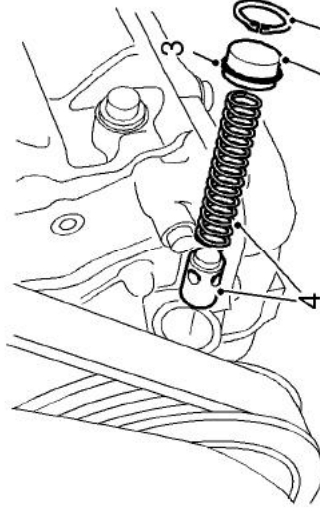

M128067

1. Remove circlip.
2. Remove relief valve plug.
3. Remove and discard 'O' ring from plug.
4. Remove relief valve spring and piston.
5. Check piston and bore of relief valve in oil pump body for scoring and corrosion.



NOTE: Light corrosion may be removed using grade 600 emery cloth soaked in oil.

ENGINE

Oil pump - inspection

1. Thoroughly clean oil pump drive gear, cover plate, rotors and housing. Remove all traces of sealant from threads of cover plate securing screws and bolt; ensure tapped holes in timing cover are clean and free from oil.
2. Check mating surfaces of cover plate, rotors and housing for scoring.
3. Assemble rotors and oil pump drive gear in housing ensuring that reference marks are aligned.

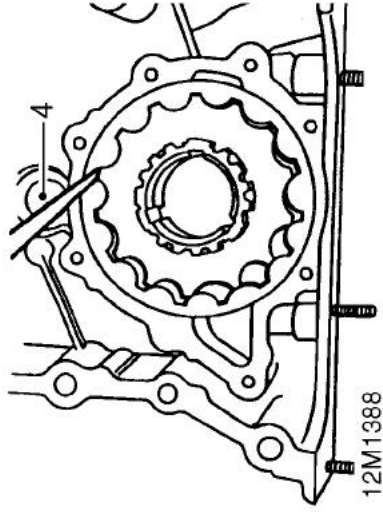

4. Using feeler gauges, check clearance between teeth of inner and outer rotors:
Maximum clearance = 0.25 mm (0.01 in)

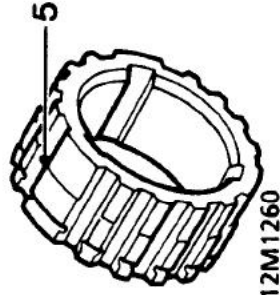

5. Remove oil pump drive gear, check depth of any wear steps on gear teeth:
Wear step maximum depth = 0.15 mm (0.006 in)

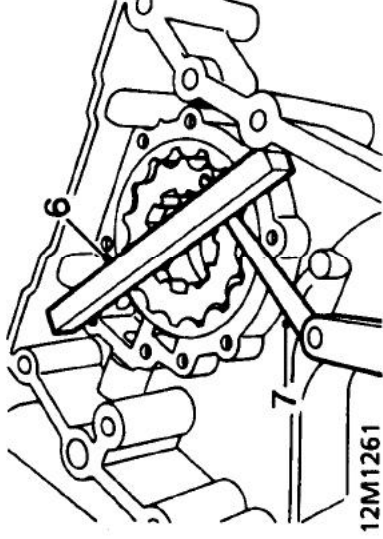

6. Place a straight edge across housing.
7. Using feeler gauges, check clearance between straight edge and rotors:
Maximum clearance = 0.1 mm (0.004 in).

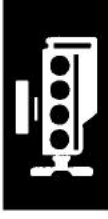

Oil pressure by-pass valve - inspection

1. Clean by-pass valve components and plunger bore in timing cover.
2. Check plunger and bore for scoring and that plunger slides freely in bore with no perceptible side movement.
3. Check by-pass valve spring for damage and distortion; check spring free length:
Spring free length = 60.0 mm (2.4 in).

Oil pressure relief valve - if fitted - inspection

1. Clean relief valve components and piston bore in timing cover.
2. Check piston and bore for scoring and that piston slides freely in bore with no perceptible side movement.
3. Check relief valve spring for damage and distortion; check spring free length:
Spring free length = 60.0 mm (2.4 in).