





Gasket - timing gear cover

➔ 12.65.04

Remove

1. Remove oil pick-up strainer.
 **ENGINE - V8, REPAIRS, Strainer - oil pick-up.**
2. Remove timing gear cover oil seal.
 **ENGINE - V8, REPAIRS, Seal - cover - timing gears.**
3. Remove engine oil filter.
 **ENGINE - V8, REPAIRS, Filter - oil.**

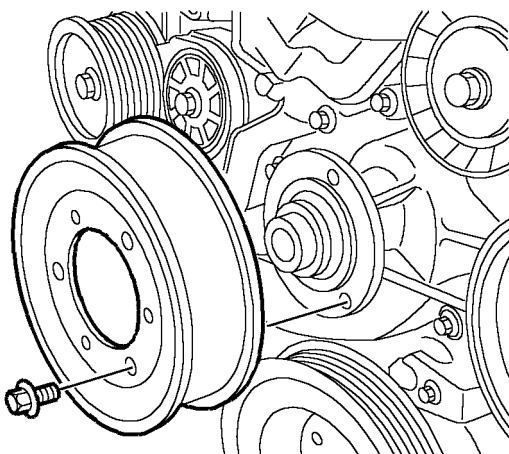

M12 4444

4. Remove and discard 3 bolts securing coolant pump pulley and remove pulley.

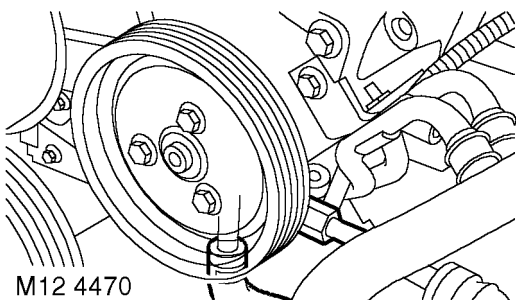

M12 4470

5. Remove 3 bolts securing PAS pump pulley and remove pulley.
6. Drain cooling system.
 **COOLING SYSTEM - V8, ADJUSTMENTS, Drain and refill.**

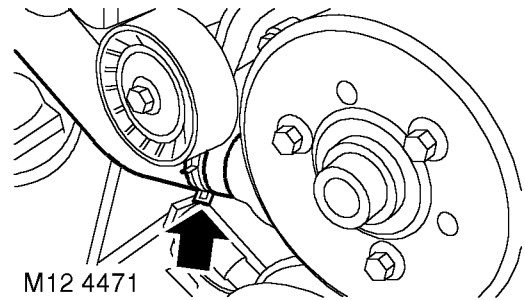

M12 4471

7. Release clip and disconnect coolant hose from coolant pump.

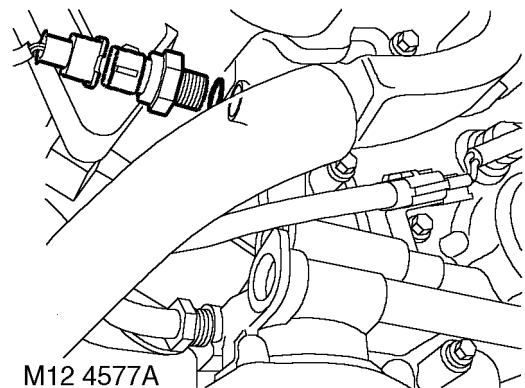

M12 4577A

8. Disconnect multiplug from oil pressure switch.
9. Disconnect multiplug from CMP sensor.
10. **If fitted:** Loosen union and disconnect oil cooler pipe from timing gear cover. Remove and discard 'O' ring.

CAUTION: Always fit plugs to open connections to prevent contamination.

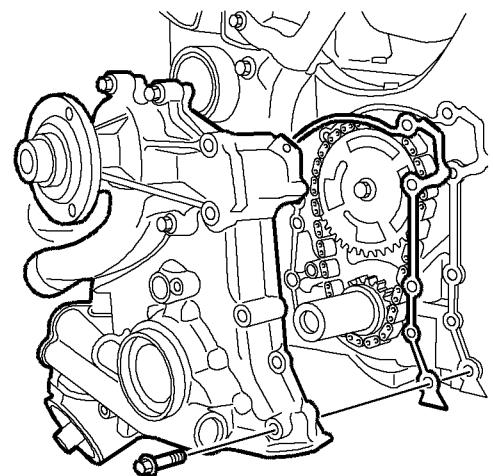

M12 7459

11. Remove 9 bolts securing timing gear cover and remove cover. Remove and discard gasket.

ENGINE - V8

Refit

1. Clean mating faces of timing gear cover and cylinder block. Clean dowels and dowel holes. Ensure bolt holes are clean and dry, remove all traces of sealant from bolt threads.
2. Fit new gasket, dry, to dowels in cylinder block.

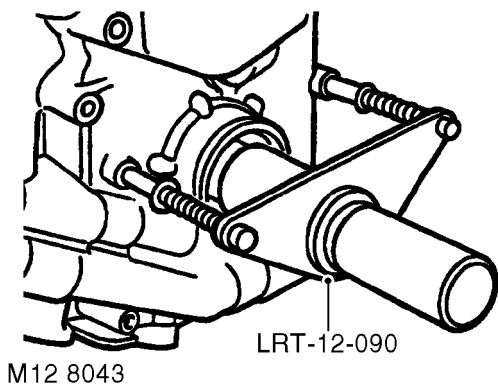

3. Locate tool **LRT-12-090** on timing cover and oil pump drive gear.
4. Position timing cover to cylinder block and at the same time, rotate tool **LRT-12-090** until drive gear keyway is aligned with Woodruff key.
5. Remove tool **LRT-12-090**.

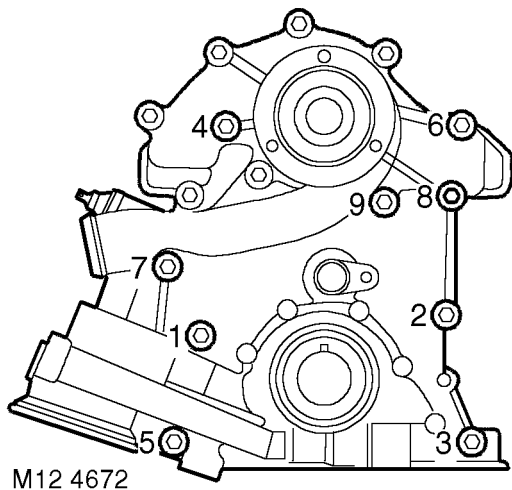

6. Apply sealant, Part Number **STC 50552** to threads of timing cover bolts, fit bolts and working in the sequence illustrated, tighten to 22 Nm (17 lbf.ft) . Ensure CMP sensor multiplug bracket is secured by bolt.
7. **If fitted:** Fit new 'O' ring to oil cooler pipe, connect pipe to timing gear cover and tighten union to 15 Nm (11 lbf.ft).
8. Connect multiplug to oil pressure switch.
9. Connect multiplug to CMP sensor.

10. Connect coolant hose to coolant pump and secure with clip.
11. Ensure mating faces of PAS pump pulley and drive flange are clean, fit pulley and tighten bolts to 22 Nm (16 lbf.ft).
12. Remove all traces of thread locking material from coolant pump pulley drive flange bolt holes using an M8 tap.
13. Ensure mating faces of coolant pump pulley and drive flange are clean, fit pulley and tighten new Patchlok bolts to 22 Nm (16 lbf.ft).
14. Ensure mating faces of oil filter and adaptor are clean, smear clean engine oil onto seal and fit filter.
15. Fit timing gear cover oil seal.
👉 **ENGINE - V8, REPAIRS, Seal - cover - timing gears.**
16. Fit oil pick-up strainer.
👉 **ENGINE - V8, REPAIRS, Strainer - oil pick-up.**
17. Refill cooling system.
👉 **COOLING SYSTEM - V8, ADJUSTMENTS, Drain and refill.**