

BRAKES

Brake system hydraulic component layout

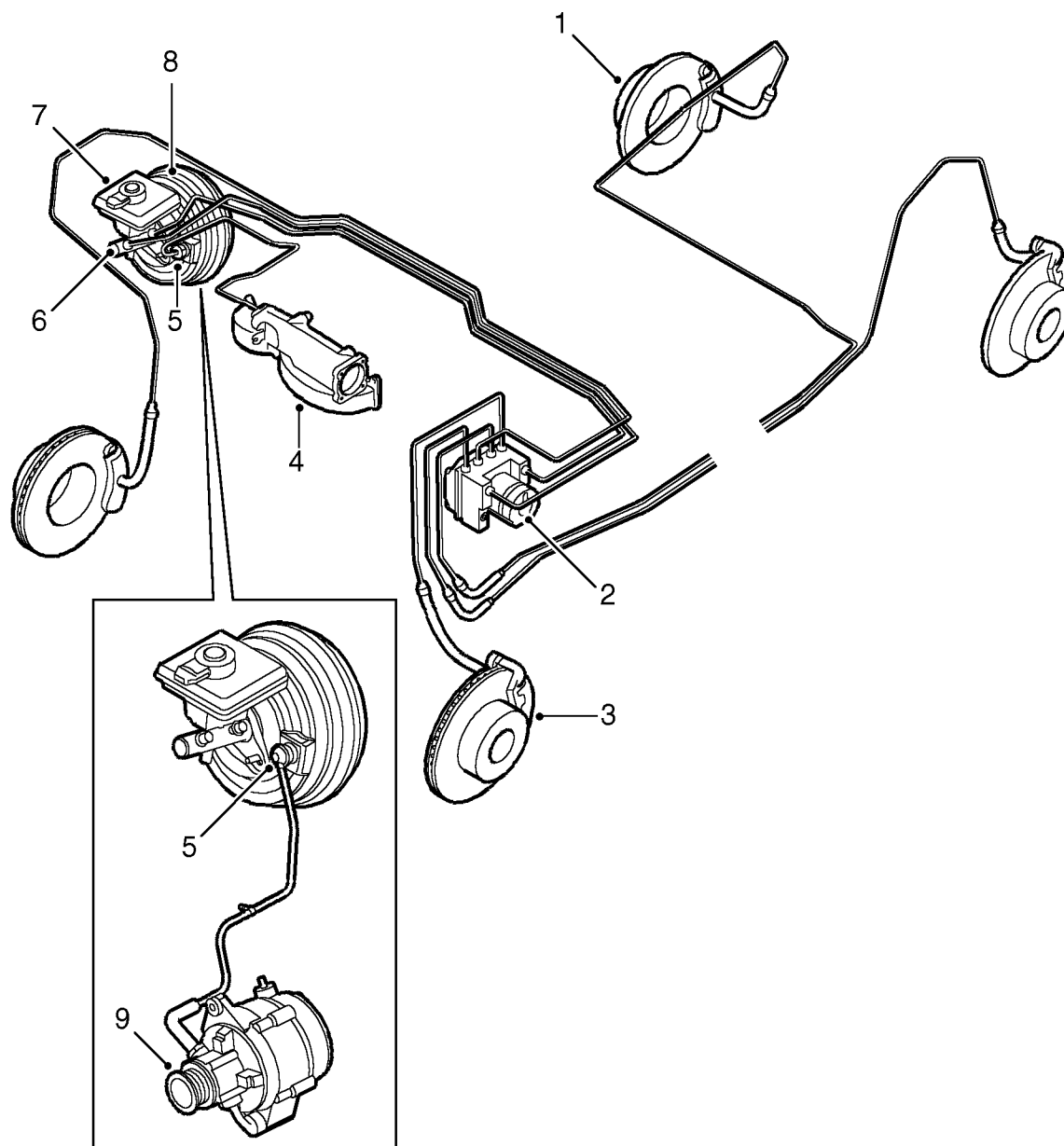

M70 0804

RH drive shown, LH drive similar

- | | |
|-------------------------------------|-------------------------------|
| 1 Rear brake | 6 Master cylinder assembly |
| 2 ABS modulator | 7 Brake fluid reservoir |
| 3 Front brake | 8 Brake servo assembly |
| 4 Inlet manifold plenum (V8 models) | 9 Vacuum pump (diesel models) |
| 5 Non return valve | |