



INTRODUCTION

The Land Rover Discovery I and Discovery II vehicles look more utilitarian and sophisticated when they sport a large iconic set of roof racks. This legendary look stems from the Camel Trophy adventure races that gained international popularity in the 80's and 90's prior the advent of reality television. The problem today is that while the price of the classic Discovery I and II's has become affordable, the costs of their iconic roof racks have not. New roof racks retail for well over \$1000 USD and used roof racks are in short supply. This instruction manual will help you solve this problem by teaching you how to build your own roof rack system capable of supporting several hundred lbs of weight, a full size 2 man tent, and a light bar, for a cost between \$100 and \$200 USD.

The novel design and 3D cad modeling of this iconic set of roof racks has taken a significant amount of effort on my part. I am giving it to you at no cost, and without any copyright or intellectual property protection. All that I ask in return is that you make a small PayPal donation if you are able to do so to jfalion@urnd.ca in the event that you are overjoyed with the results of your new roof rack system.

Waiving All Liability

This is an open source research and development project undertaken not for profit. However, as a licensed Professional Engineer, I understand that the law does not make any distinction between for pay and not for pay engineering services offered to the public. That being said, I cannot control the skill, mounting strategy, nor safety of this roof rack system for public use at this time. As a result, I am clearly stating this waiver of liability absolving myself of any damages done to persons or property inspiring their work from this project. I waive my duty of care to the public. Proceed at your own risk.

URND Roof Rack V1.0

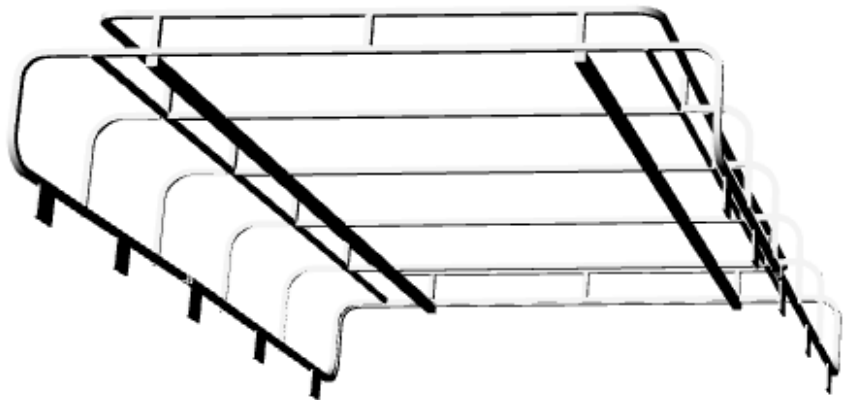

URND Roof Rack Features

- Does not occlude sunroof view.
- Front sunroof can open all the way even when rack is installed.
- Supports a full size 2 person tent.
- Can support several hundred lbs of gear.
- Can be walked on.
- Low profile design.

Required Tools

- Tape measure
- Sharpie marker
- Conduit bender (5 in. bend radius)
- Saw with metal cutting blade (skill saw, saws all, or angle grinder)
- MIG Welder or case of beer to bribe someone who owns one.
- Degreaser and cloth / Sand paper / Spray paint.

Required Materials:

- (x4) 14 ft. long, 5/8 in. wide square steel tubing of 1/16 in. wall thickness.
- (x6) 8 ft. long 5/8 in. wide square steel tubing of 1/16 in. wall thickness.
- (x2) 8 ft. long 1 in. wide square steel tubing of 1/8 in. wall thickness.
- (x1) 30 in. of 3 in. tall by 1/4 in. thick steel plate.
- Rum, coke, gin, tonic, beer.

Step-by-Step Cutting Instructions

1. Select **two** 14 ft. long sticks of 5/8 in. square steel tubing with 1/16 in. wall thickness and lay them flat on a solid floor.

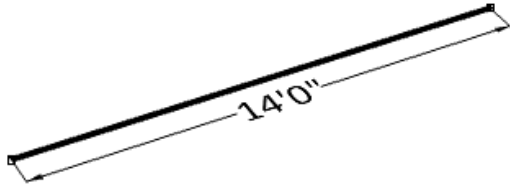

2. Use a sharpie to mark the middle of each stick (measure 7 ft. from the ends).

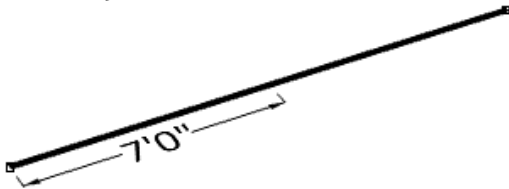

3. Use a sharpie to make two marks 30 in. (2' 6") on either side of the middle point you just marked on each stick.

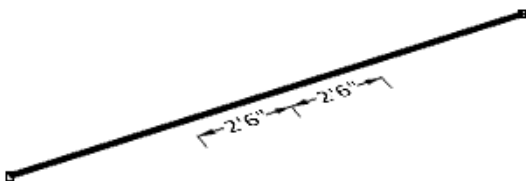

*You want the final width of the roof rack to be 56 in. wide to fit nicely into the gutters. That means that you want 28 in. on either side of the middle point, however your conduit bender will suck up 2 in. of tube to make the 90 degree corners hence the 30 in. (2'6") marks.

4. Place the conduit bender on the square steel tubing and bend one side at a time (x4) to a 90-degree angle towards the middle mark.

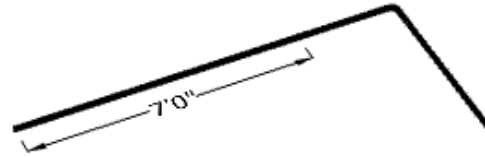

*To use the conduit bender, line up the arrow on the bender with the 30 in. marks that you made and bend towards the middle point of the tube. Try to put as much weight as you can on the foot pedal and pull as little as possible with your arms to minimize the introduction of bends in the straight sections of the square steel tubing. The conduit bender is designed for round copper tubing, I have already compensated for this within the measurements outlined in this document - don't worry about it.

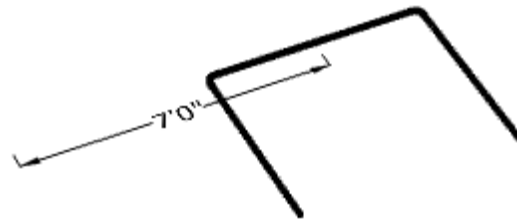

5. Use a sharpie and tape measure to mark 11.25 inches from the floor towards the extremities of the square steel tubes (x4).

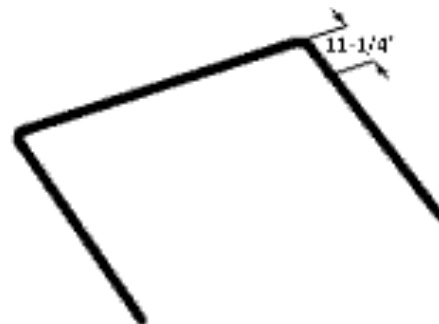

6. Make 90-degree bends (x4) perpendicular to your previous bends (bending towards your previous bends such that the end result is two 9.25 in. tall, 56 in. wide, 3D bent members).



7. Place the two bent members on the ground. Position them opposing each other and use your hands to manipulate them until they fit loosely together.



You don't have to worry about perfection here, When you weld in the struts it will force these members to go straight.

8. Test fit the 3D members on your land rover. Use your sharpie to mark where the two members intersect. You will cut here to determine the overall length of the roof racks. Land Rover Discovery I's are 6 in. shorter than Discovery II's, but share a common width.

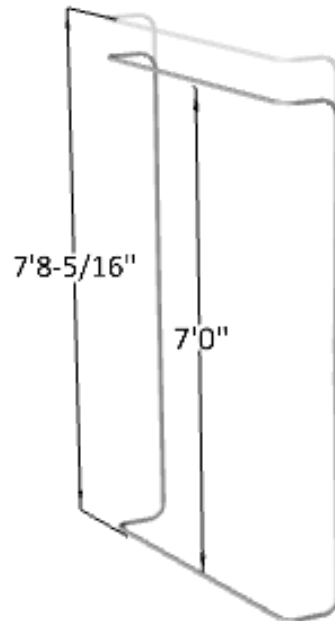

*I chose mine to be 7 feet long. This is a question of personal preference. This is also a good time to test fit your lights. You want them far enough back that they look good and far enough forward that they don't overlap your sunroof. The following measurements assume that you chose a 7 ft. long roof rack as well.

9. Use a saw with a metal cutting blade to cut one member at the locations that you just marked with your sharpie.

*Be sure to cut only one member or they won't fit together.

10. Cut two of the 8 ft. 5/8 in. wide, 1/16 in. wall thickness square steel tubing pieces to fit inside the 3D bent members (6 ft. 10-3/5" lengths).

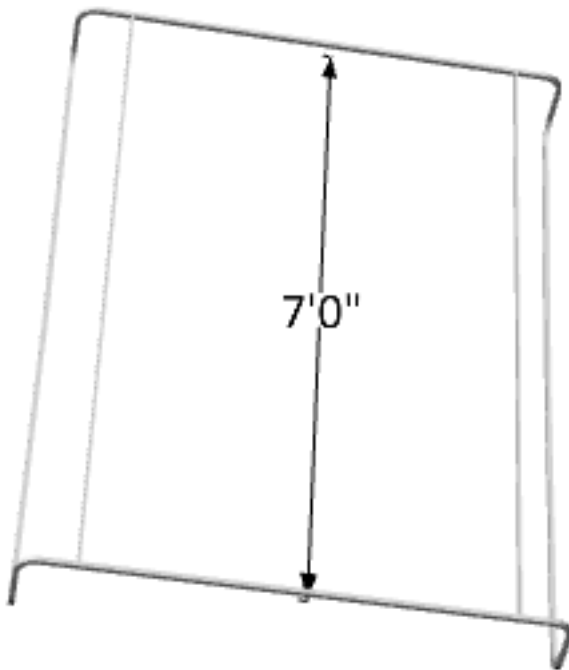

*In the case of a 7 ft. long rack, these members would be cut to 6 ft. 10 3/4 in. lengths.

11. Cut the remaining two 8 ft. 5/8 in. wide, 1/16 in. wall thickness square steel tubing pieces in half yielding 4 ft. horizontal sections (x4).

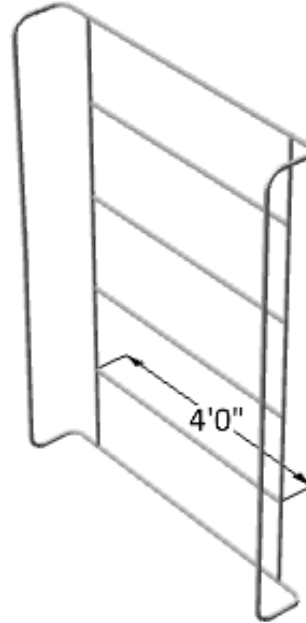

12. Cut both 8 ft. 1 in. wide, 1/8 in. wall thickness square steel tubing pieces to fit the length of your roof rack (outside to outside).

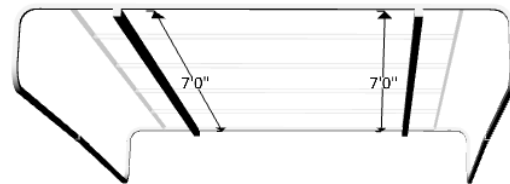

*In the case of a 7 ft. long rack these members would be cut to 7 ft. lengths.

13. Use your sharpie to mark the middles of the two remaining 14 ft. 5/8 in. 1/16 in. wall thickness square steel tubes.

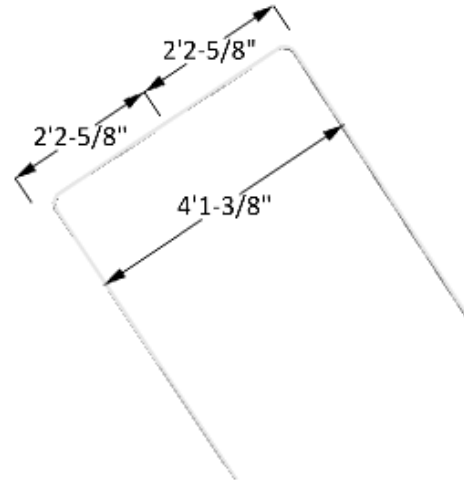
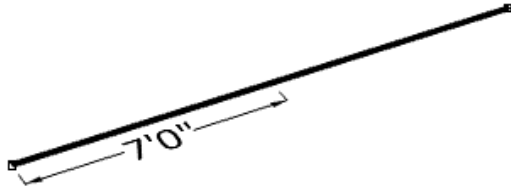

14. Use your sharpie once more to mark 26 5/8 in. on either side of the middle markings on each of these members.

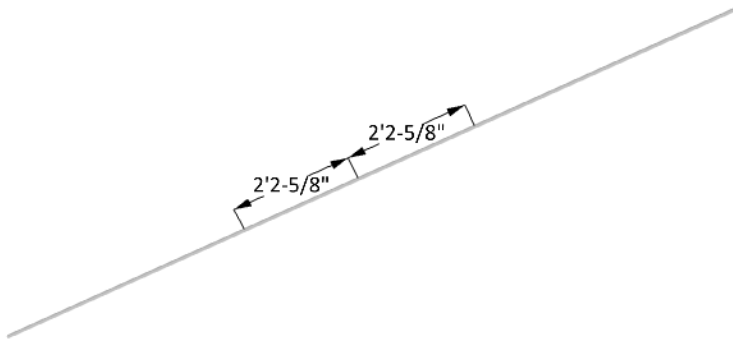

16. Place these two bent members on top of your project and mark where they overlap such that they are the same length (outside to outside) as your project.

*In the case of a 7 ft. rack, they should be marked to make them 7 ft long.

15. Use the conduit bender to bend 90 degree corners (x4) starting at the markings you just scored and bending towards the center of the member.

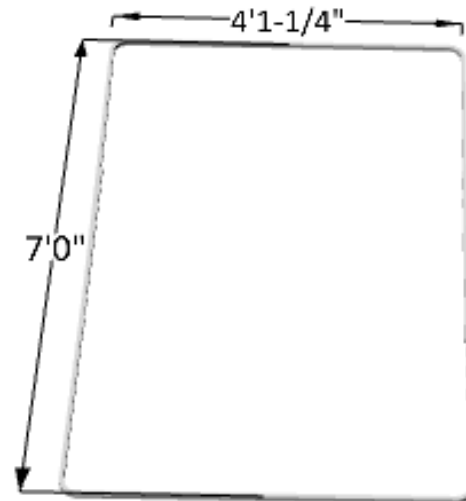
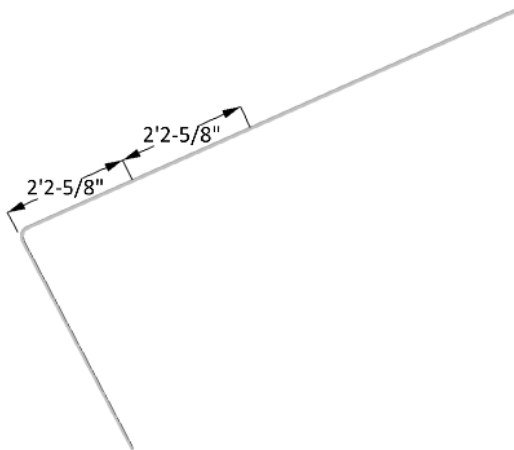

17. Use a saw with metal cutting blade to cut one member where your markings are located.

18. Use a saw with metal cutting blade to cut 3 in. long pieces (x14) to support the top of your roof rack basket.

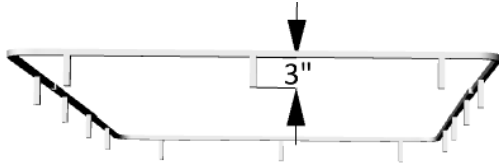

19. Use a saw with metal cutting blade to cut 2 ft. sections of the remaining two 8 ft. long 5/8 in. wide 1/16 in. wall thickness square steel tubing (x8).

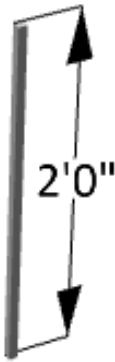

20. Bend the centers of these eight 2 ft. sections of square steel tubing to approximately 90 degree angles.



*These pieces are cut intentionally too long. You will use an angle grinder to cut them to size individually as one of the last steps in the welding process. Welding will introduce some geometric error into your system, you will be able to

compensate for that by customizing these 8 pieces once all other pieces are welded in place.

21. Use a saw with metal cutting blade to cut 3 in. long by 3 in. tall pieces of 1/4 in. steel plate (x10) to form the supports that will be lodged in the roof gutters. You can skip this step if you buy gutter L-bracket supports off e-bay.



* You will likely want to resize these 10 pieces as the second last step of the welding process during a test fitting of the final assembly. The height of these pieces will determine the final height of your roof rack system (ensuring enough space between the rack and the roof to open your front sunroof).

Congratulate yourself, have a few beers on me and take the rest of the night off. You are ready to weld your roof rack together tomorrow.

Step-by-Step Welding Instructions:

1. Begin by welding the two 3D members together.



2. Weld the 4 ft. cross sections to the two 5/8 in. longitudinal members.

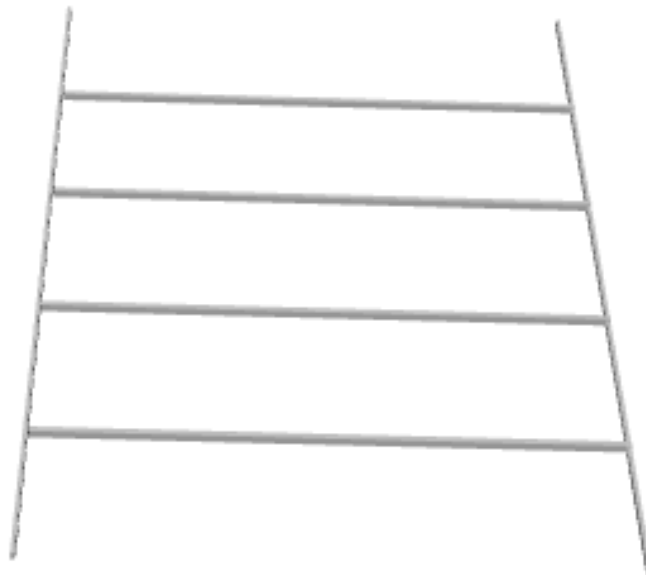

3. Flip the 3D members assembly upside down and weld it to the cross section assembly. Make sure to center it.



4. Weld the two 1 in. wide 1/8 in. wall thickness support members to the underside of the 3D assembly. Be sure to weld them 6 in. from the outside edges of the roof racks so that they are not visible when you are looking out the sunroof. Weld it to each of the cross section members and cap the ends so that water cannot enter while you are driving.



5. Weld the two rounded rectangle basket members together.



6. Weld the 3 in. supports to the 3D assembly. Then weld the basket members to the opposite sides of the 3 in. supports.



7. Weld the steel plates to the bottom of the roof rack.

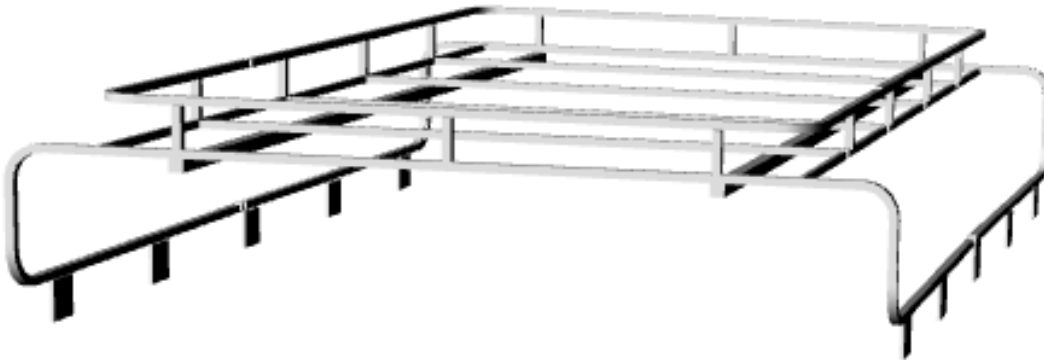

8. **IMPORTANT:** Test fit the roof racks on your Land Rover at this point. You can deform it by hammering the steel plates or bending the members at this time to make it fit. This is your last chance to do so. This is also the time to test fit your lights to drill any holes that might be necessary. This roof rack looks much better with lights attached to the front.

9. Cut and weld the 90-degree supports (x8) on either side of the roof racks. Measure, cut, and weld these individually to fit with the natural imperfections in the final geometry.

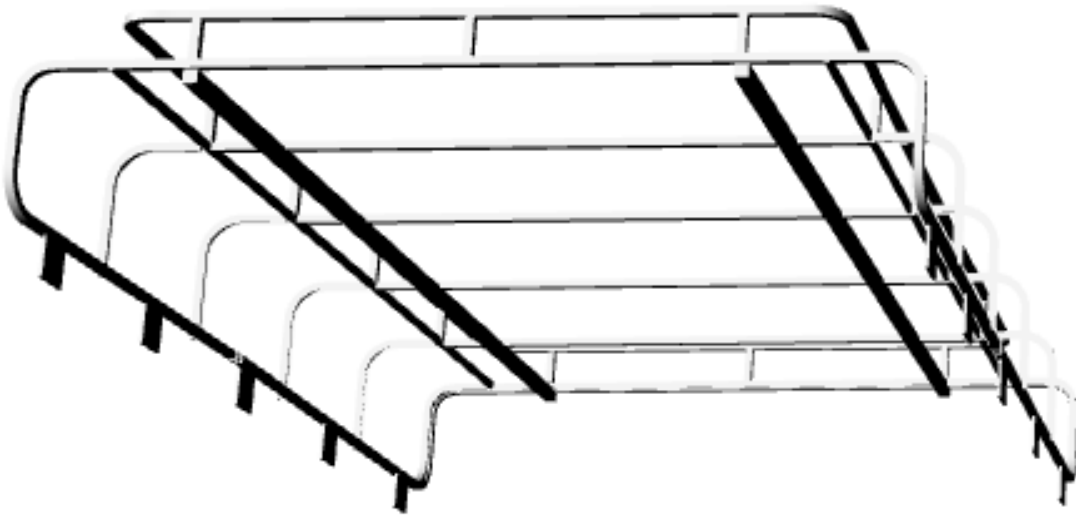

10. You may install and weld a roof rack bed at this time, or wait until later to zip tie it on.

11. Give yourself a pat on the back. The worst is over. It's time to get some dark Cuban rum and coke and take the rest of the day/night off.

Painting Instructions:

1. Dampen the cloth with degreaser and rub it on all steel members. There is usually a layer of oil on the steel members that will interfere with proper paint adhesion.



2. Scratch each member with 400 grit sand paper, this will help with primer adhesion.

3. Prime with a primer of your choice. Wait for it to set.

4. Paint it with a paint of your choosing. I recommend something that includes rust proofing such as Tremclad followed by a second coat of bedliner for a nice matt textured finish.



While you wait for it to dry, sip on some gin and tonics as your new roof racks will have increased your sophisticated look. Since it takes a while for the paint to dry, you should send me an email at jfilion@urnd.ca to let me know that you have built them. I will pour a gin and tonic in your honor when I receive your email. Please donate a small sum via PayPal if you have the means to do so.