

Drive Shafts and Universal Joints

Upon completion and review of this chapter, you should be able to:

- ❑ Understand and describe the purpose and construction of common RWD drive shaft designs.
- ❑ Understand and describe the purpose and construction of common Universal joint designs.
- ❑ Explain the importance of drive shaft balance.
- ❑ Explain the natural speed variations inherent to a drive shaft.
- ❑ Describe the effects of canceling Universal joint angles.

Introduction

On front engine rear-wheel-drive cars, the rotary motion of the transmission's output shaft is carried through the drive shaft to the differential, which causes the rear drive wheels to turn (Figure 6-1).

The **drive shaft** is normally made from seamless steel or aluminum tubing with Universal joint yokes welded to both ends of the shaft (Figure 6-2). To save weight, some manufacturers use epoxy-and-carbon fiber shafts. Some drive lines have two drive shafts and three Universal joints and use a center support bearing that serves as the connecting link between the two halves (Figure 6-3).

Four-wheel-drive vehicles use two drive shafts, one to drive the front wheels and the other to drive the rear wheels (Figure 6-4). FWD cars, 4WD vehicles equipped with an independent front suspension, and RWD vehicles equipped with independent rear suspension use an additional

The **drive shaft** is an assembly of one or two Universal joints connected to a shaft or tube used to transmit power from the transmission to the differential. It is also called the propeller shaft.

Although most late model cars are front-wheel drive, which are not equipped with a drive shaft and Universal joints, the best selling vehicles in America are pickup trucks, which do have a drive shaft and Universal joints. These, plus the many older cars on the road, give many opportunities to technicians trained in the diagnosis and repair of drive shafts and Universal joints.

The short drive shafts or axles used on FWD, 4WD, and RWD with IRS are called half-shafts.

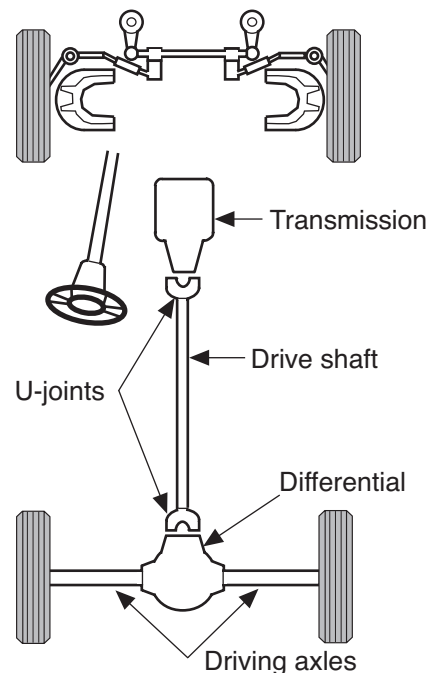

Figure 6-1 RWD drive train.

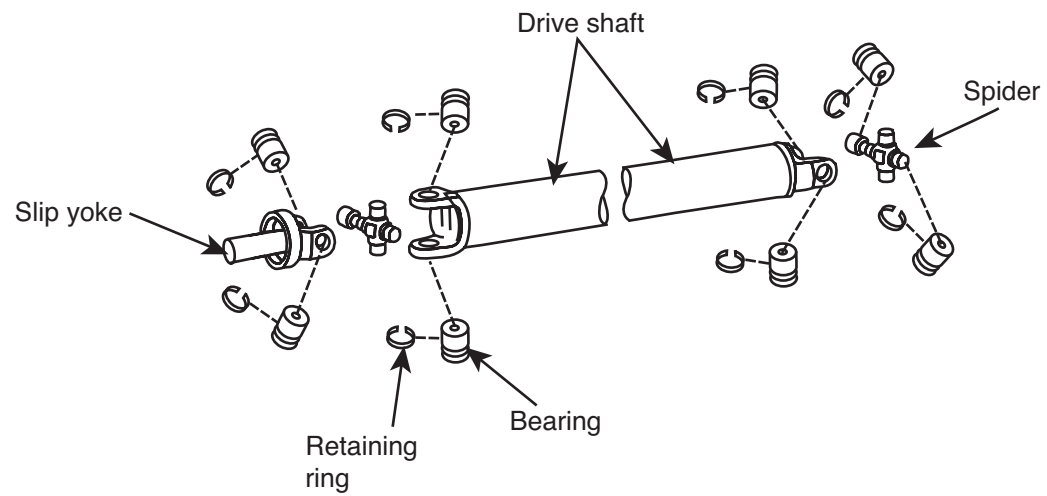

Figure 6-2 Typical drive shaft assembly.

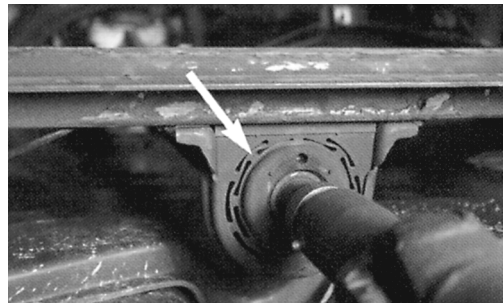

Figure 6-3 A two-piece drive shaft is often used when there is a great distance between the transmission and the rear axle.

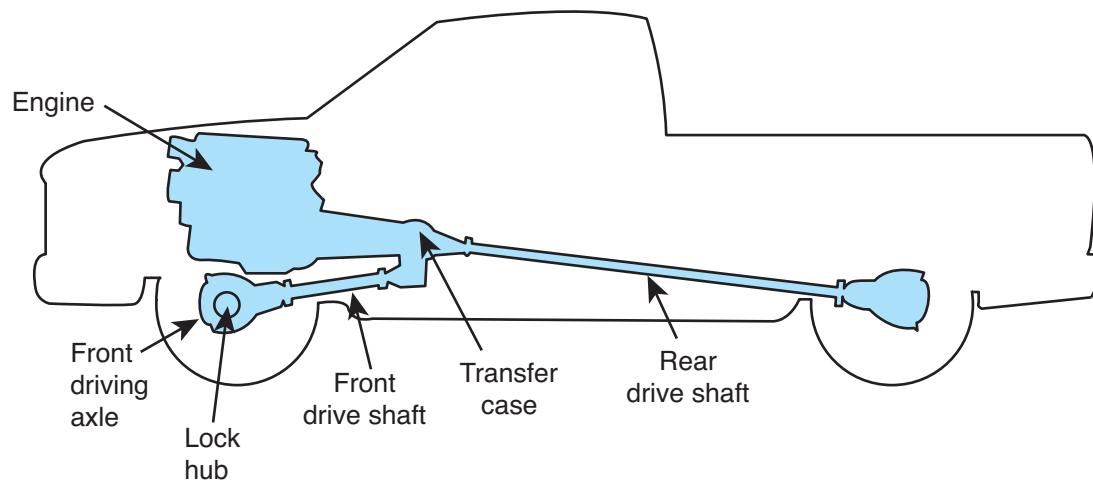

Figure 6-4 4WD truck with two drive shafts.

pair of short drive shafts. These shafts are actually the car's drive axles, which transmit the torque from the differential to each drive wheel.

A BIT OF HISTORY

The Autocar, in 1901, was the first car in the United States to use a drive shaft.



Drive Shaft Construction

Two facts must be considered when designing a drive shaft: the engine and transmission are more or less rigidly attached to the car frame and the rear axle housing, with the wheels and differential attached to the frame by springs. As the rear wheels encounter irregularities in the road, the springs compress or expand. This changes the angle of the driveline between the transmission and the rear axle housing. It also changes the distance between the transmission and the differential.

In order for the drive shaft to respond to these constant changes, drive shafts are equipped with two or more universal joints that permit variations in the angle of the shaft, and a slip joint that permits the effective length of the driveline to change.

A drive shaft is actually an extension of the transmission's output shaft, as its sole purpose is to transfer torque from the transmission to the drive axle assembly (Figure 6-5). It is usually made from seamless steel or aluminum tubing with a yoke welded or pressed onto each end, which provides a means of connecting two or more components together.

The drive shaft, like any other rigid tube, has a natural vibration frequency. This means that if one end of the tube were held tightly, the tube would vibrate at its own frequency when it is deflected and released or when it rotates. It reaches this natural frequency at its critical speed. The critical speed of a drive shaft depends on the diameter of the tube and the length of the drive shaft. Drive shaft diameters are as large as possible and shafts as short as possible to keep the critical speed frequency above the normal driving range.



Shop Manual

Chapter 6, page 236

In normal automotive terms, suspension spring compression is called jounce.

The expansion of a suspension spring is suspension rebound.

Critical speed is the rotational speed at which an object begins to vibrate as it turns. This is mostly caused by centrifugal forces.

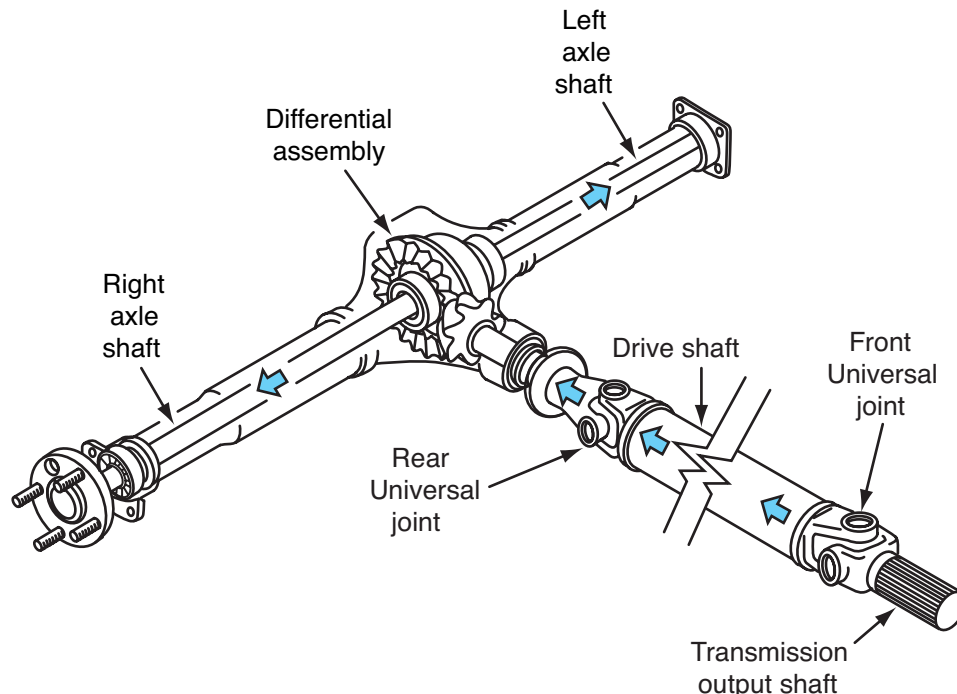

Figure 6-5 Power flows from the transmission to the rear axle.

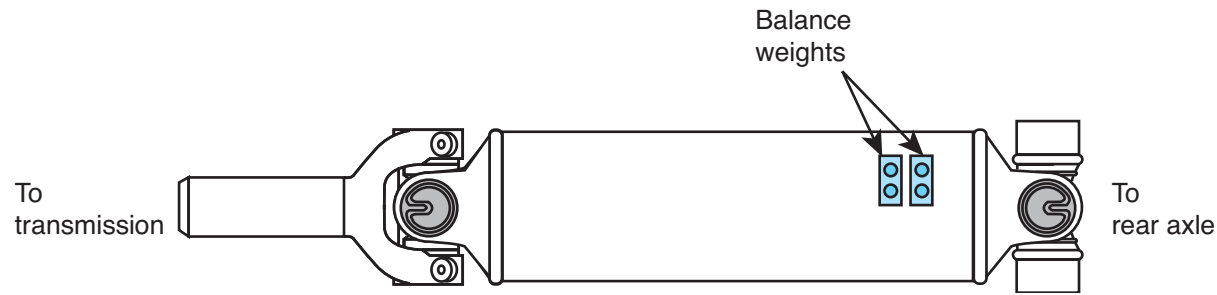

Figure 6-6 Location of the balance weights on a drive shaft.

A drive shaft rotates at three to four times the speed of the car's tires.

Linear stiffness means the shaft will resist deflection regardless of length.

Because the drive shaft rotates at high speeds and at varying angles, it must be balanced to reduce vibration. As the drive shaft's length and the operating angle and speed increase, the necessity for balance also increases. Several methods are used to balance drive shafts. One of the most common techniques employed by manufacturers is to balance the drive shaft by welding balance weights to the outside diameter of the drive shaft (Figure 6-6).

To reduce the effects of vibrations and the resulting noises, manufacturers have used various methods to construct a drive shaft. An example of this is a drive shaft with cardboard liners inserted into the tube, which serve to decrease the shaft's vibration by damping the vibrations.

Drive shaft performance has also been improved by placing biscuits between the drive shaft and the cardboard liner. These biscuits are simply rubber inserts that reduce noise transfer within the drive shaft.

Another drive shaft design is the tube-in-tube, in which the input driving yoke has an input shaft that fits inside the hollow drive shaft. Rubber inserts are bonded to the outside diameter of the input shaft and to the inside diameter of the drive shaft. This design reduces the noise associated with drive shafts when they are stressed with directional rotation changes and also greatly reduces the vibration.

Recently, drive shafts have begun to be made with aluminum tubing or fiber composites. These composites give the shaft linear stiffness, while the positioning of the fibers provide for torsional strength. The advantages of a fiber composite drive shaft are weight reduction, torsional strength, fatigue resistance, easier and better balancing, and reduced interference from shock loading and torsional problems.



AUTHOR'S NOTE: Common causes of driveline vibrations are bad U-joints and missing balance pads on the drive shaft. While checking the U-joints, check the drive shaft for the balance pads. Nearly all drive shafts have them so if you don't find them, that is probably the reason for the vibration.

Types of Drive Shafts

Three types of drive shafts have been used in automobiles. The first type, and the most commonly used, is the **Hotchkiss drive**. This type of drive shaft is readily recognized by its external shaft and U-joints (Figure 6-7). These shafts are either one- or two-piece assemblies consisting of a shaft with U-joints attached to each end. A Hotchkiss drive system can be used with either leaf or coil springs. When it is used with coil springs, additional braces, called control arms, must be used to control the movement of the rear drive axle (Figure 6-8).

A two-piece drive shaft is used on many long wheelbase vehicles. It uses a third U-joint between the two shaft sections and a center bearing to support the middle of the shaft assembly (Figure 6-9).

The second type of drive shaft is called a **torque tube**. Vehicles with independent rear suspension and a rear-mounted transaxle—such as late model Corvettes and some Japanese RWD cars—use a torque tube. On these cars, the torque tube is rigidly connected at both ends. The

The **torque tube** is a fixed tube over the drive shaft on some cars. It helps locate the rear axle and takes torque reaction loads from the drive axle so the drive shaft will not sense them.

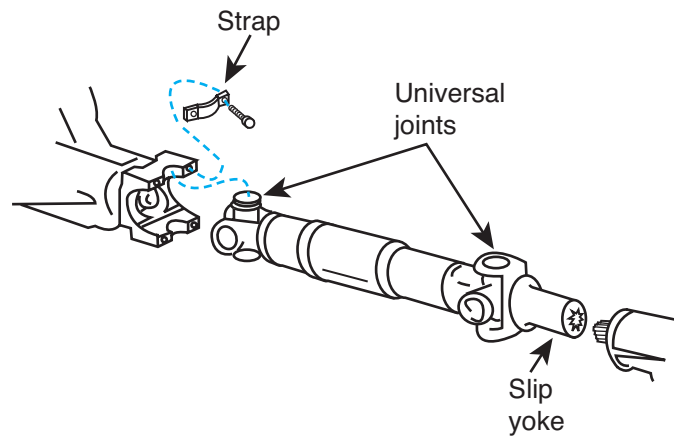

Figure 6-7 Hotchkiss drive.

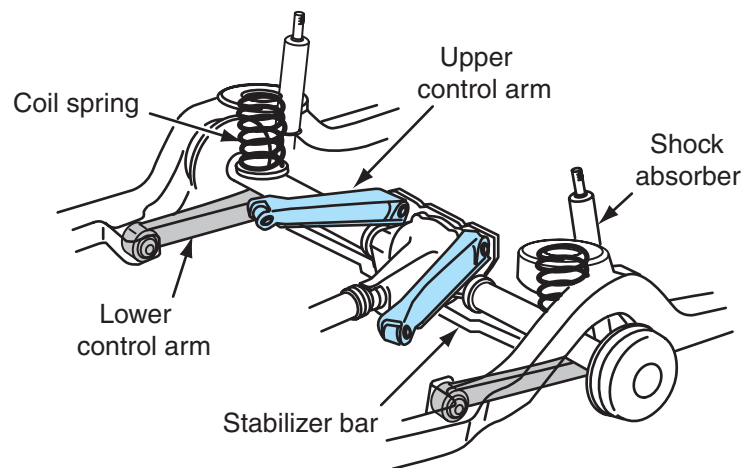

Figure 6-8 Hotchkiss drive with a coil spring suspension.

rotating inner drive shaft does not need universal joints because the transaxle location never changes relative to engine location (Figure 6-10). The Chevrolet Chevette used a two-piece drive shaft in which the forward section was a tubular shaft with universal joints at each end and the rear section was a torque tube that was rigidly mounted to the differential.

The third and least commonly used type of drive shaft is the flexible type. This shaft is actually a flexible steel rope, much like an oversized speedometer cable that does not use universal joints between the engine and the rear-mounted transaxle. The 1961–1963 Pontiac Tempest models used this type of drive shaft.

Universal Joints

A drive shaft must smoothly transfer torque while rotating, changing length, and moving up and down. The different designs of drive shafts all attempt to ensure a vibration-free transfer of the engine's power from the transmission to the differential. This goal is complicated by the fact that the engine and transmission are bolted solidly to the frame of the car while the differential is mounted on springs. As the rear wheels go over bumps in the road or changes in the road's

A **Hotchkiss drive** system actually describes the entire drive shaft and rear axle assembly. This system allows the rear axle to move with the suspension while allowing torque to be transferred from the transmission to the rear axle. It is commonly called an open drive shaft system.

A two-piece drive shaft is also referred to as a split drive shaft.

A torque tube system is commonly called an enclosed drive shaft system.

The joint's cross is often called its spider.

The arms of the joint are also called trunnions.



Shop Manual
Chapter 6, page 241

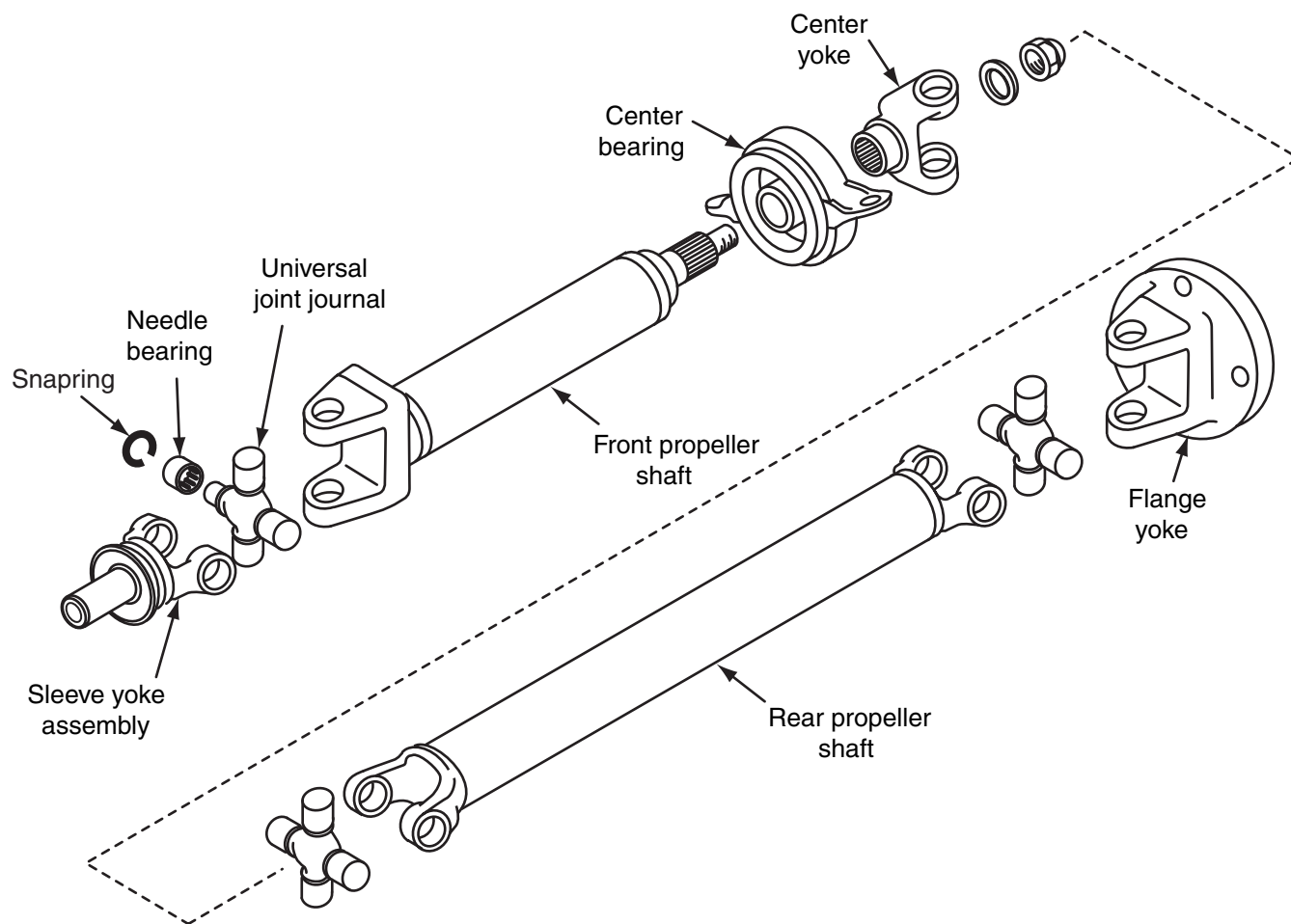

Figure 6-9 A two-piece drive shaft assembly.

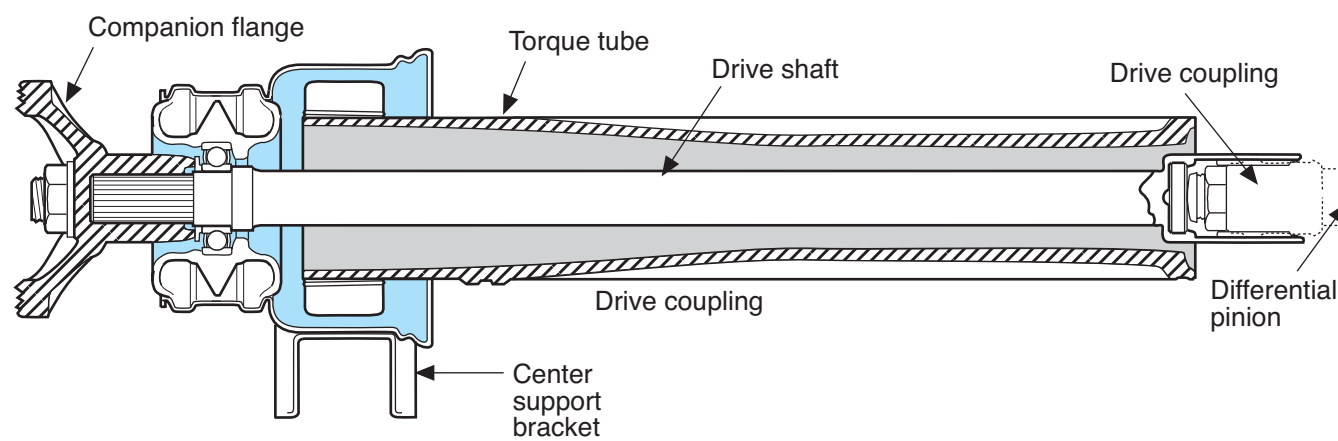

Figure 6-10 A typical torque tube assembly.

surface, the springs compress or expand. This changes the angle of the drive shaft between the transmission and the differential, as well as the distance between the two (Figure 6-11). To allow for these changes, the Hotchkiss-type drive shaft is fitted with at least two U-joints to permit variations in the angle of the drive and a slip joint that permits the effective length of the drive shaft to change. The Universal joint is basically a double-hinged joint consisting of two Y-shaped yokes, one on the driving or input shaft and the other on the driven or output shaft, plus a cross-shaped unit called the cross (Figure 6-12). A **yoke** is used to connect the U-joints together. The four arms of the cross are fitted with bearings in the ends of the two shaft yokes. The input shaft's yoke causes the cross to rotate, and the two other trunnions of the cross cause the output shaft to rotate. When the two shafts are at an angle to each other, the bearings allow the yokes to swing around on their trunnions with each revolution. This action allows two shafts, at a slight angle to each other, to rotate together.

The joint's **yoke** is a Y-shaped assembly into which two of the joint's arms fit.

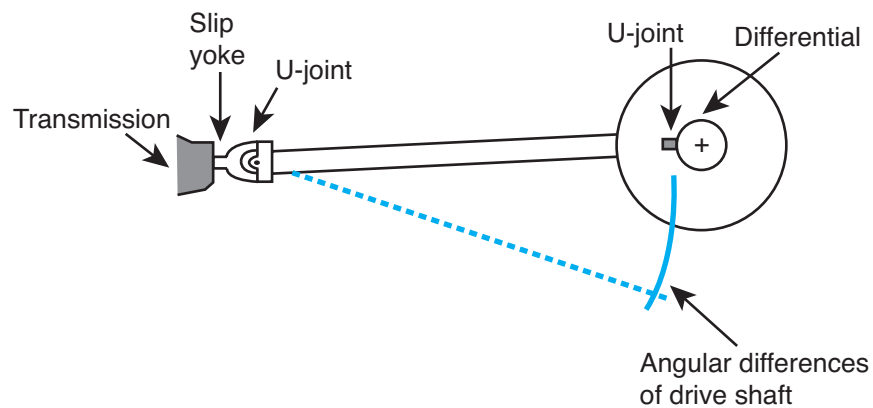

Figure 6-11 An illustration showing the changes in the length and angle of a drive shaft.

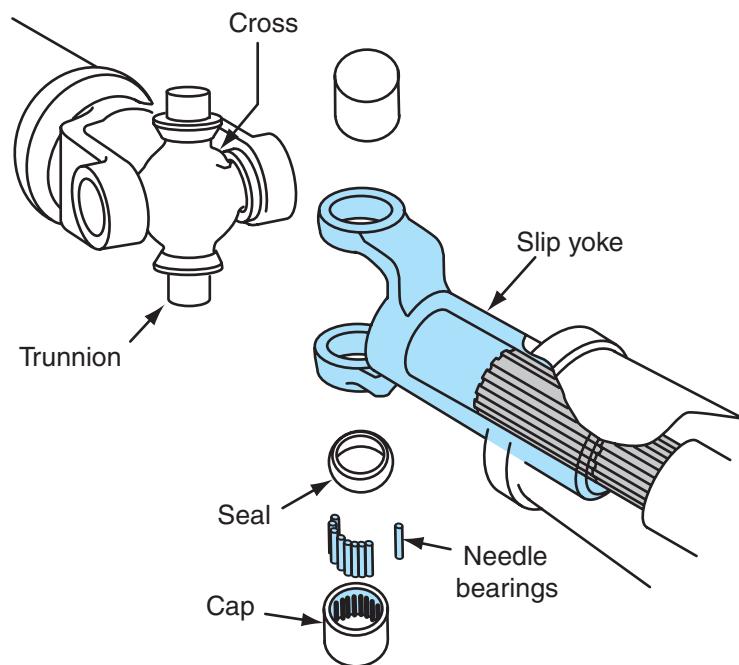

Figure 6-12 An exploded view of a Cardan U-joint.

Universal joints allow the drive shaft to transmit power to the rear axle through varying angles that are controlled by the travel of the rear suspension. Because power is transmitted on an angle, U-joints do not rotate at a constant velocity nor are they vibration free.

A BIT OF HISTORY

The original Universal joint was developed in the sixteenth century by a French mathematician named Cardan. In the seventeenth century, Robert Hooke developed a cross-type Universal joint, based on the Cardan design. Then in 1902, Clarence Spicer modified Cardan and Hooke's inventions for the purpose of transmitting engine torque to an automobile's rear wheels. By joining two shafts with Y-shaped forks to a pivoting cruciform member, the problem of torque transfer through a connection that also needed to compensate for slight angular variations was eliminated. Both names, Spicer and Hooke, are at times used to describe a Cardan U-joint.



Speed Variations

Although simple in appearance, a U-joint is more intricate than it seems. Its natural action is to cause the shaft it is connected to, to speed up and slow down twice during each revolution, while operating at an angle. The amount that the speed changes varies according to the steepness of the universal joint's angle.

As a U-joint transmits torque through an angle, its output shaft speed increases and decreases twice on each revolution. These speed changes are not normally apparent, but may be felt as torsional vibration due to improper installation, steep and/or unequal operating angles, and high speed driving.

If a U-joint's input shaft speed is constant, the speed of the output shaft accelerates and decelerates to complete a single revolution at the same time as the input shaft. In other words, the output shaft falls behind, then catches up with the input shaft during this revolution. The greater the angle of the output shaft, the more the velocity will change each shaft revolution.

U-joint **operating angle** is determined by the difference between the transmission **installation angle** and the drive shaft installation angle (Figure 6-13). When the U-joint is operating at an angle, the driven yoke speeds up and slows down twice during each drive shaft revolution. This acceleration and deceleration of the U-joint is known as speed variation.

These four changes in speed are not normally visible during rotation, but may be understood after examining the action of a U-joint. A universal joint serves as a coupling between two shafts that are not in direct alignment. It would be logical to assume that the entire unit simply rotates. This is only true of the joint's input yoke.

The output yoke's rotational path looks like an **ellipse** because it can be viewed at an angle instead of straight on. This same effect can be obtained by rotating a coin with your fingers. The height of the coin stays the same even though the sides seem to get closer together.

The **operating angle** of a drive shaft is the amount the drive shaft deviates from the horizontal plane.

The **installation angle** of an object describes how far the object is tilted away from the horizontal plane.

An **ellipse** is merely a compressed form of a circle.

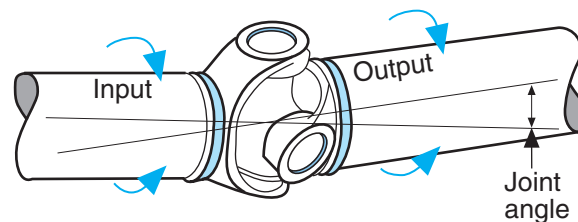

Figure 6-13 Universal joint angles.

This might seem to be merely a visual effect, however it is more than that. The U-joint rigidly locks the circular action of the input yoke to the elliptical action of the output yoke. The result is similar to what would happen when changing a clock face from a circle to an ellipse.

Like the hands of a clock, the input yoke turns at a constant speed in its true circular path. The output yoke, operating at an angle to the other yoke, completes the path in the same amount of time (Figure 6-14). However, its speed varies, or is not constant, compared to the input.

Speed variation is more easily visualized when looking at the travel of the yokes by 90-degree quadrants (Figure 6-15). The input yoke rotates at a steady or constant speed through a complete 360-degree rotation. The output yoke quadrants alternate between shorter and longer distances of travel than the input yoke quadrants. When one point of the output yoke covers the shorter distance in the same amount of time, it must travel at a slower rate. Conversely, when traveling the longer distance in the same amount of time, it must move faster.

Because the average speed of the output yoke through the four 90-degree quadrants equals the constant speed of the input yoke during the same revolution, it is possible for the two mating yokes to travel at different speeds. The output yoke is falling behind and catching up constantly. The resulting acceleration and deceleration produces fluctuating torque and torsional vibrations and is characteristic of all Cardan U-joints. The steeper the U-joint angle, the greater the speed fluctuations. Conversely, smaller angles produce less change in speed.

The speed variation of a Universal joint is sometimes called speed fluctuation.

A quadrant is another name for a quarter of something.

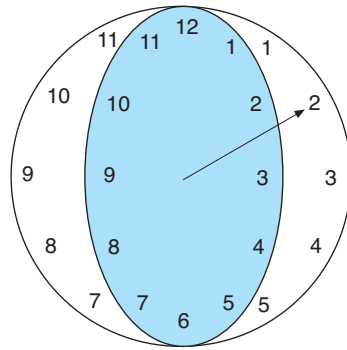

Figure 6-14 The face of a clock can be used to illustrate the elliptical action of the drive shaft's yokes.

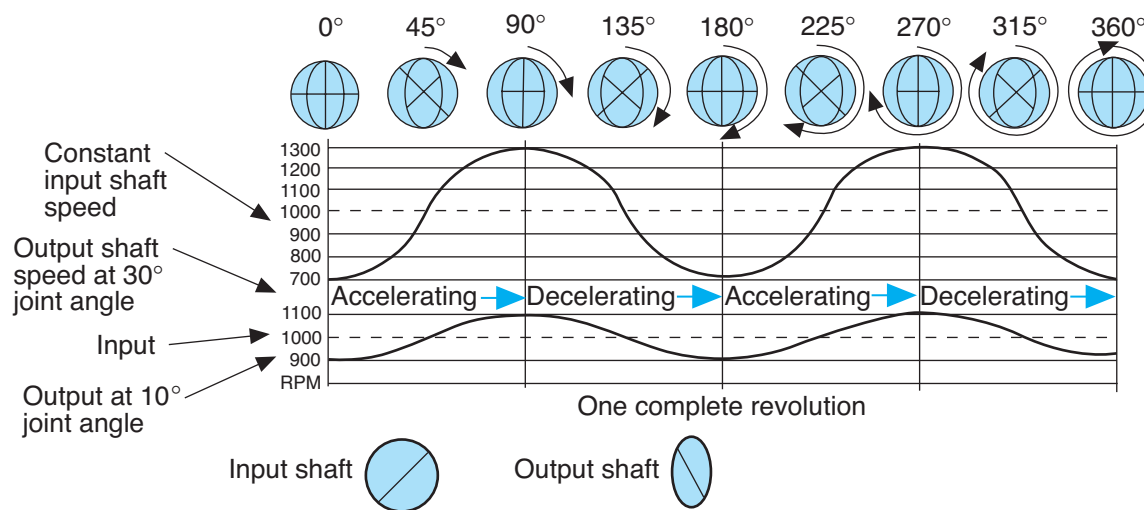

Figure 6-15 A chart showing the speed variations of a drive shaft's yoke.



Shop Manual

Chapter 6, page 253

In-phase describes the condition in which two events happen one after the other, regardless of speed.



Shop Manual

Chapter 6, page 253

Canceling angles occur when the opposing operating angles of two Universal joints cancel the oscillations developed by the individual Universal joint.

Phasing of Universal Joints

The torsional vibrations set up by the changes in velocity are transferred down the drive shaft to the next U-joint. At this joint, similar acceleration and deceleration occurs. Because these speed changes take place at equal and reverse angles to the first joint, they cancel out each other whenever both occur at the same angle. To provide for this canceling effect, drive shafts should have at least two U-joints and their operating angles must be slight and equal to each other. Speed fluctuations can be canceled if the driven yoke has the same point of rotation, or same plane, as the driving yoke. When the yokes are in the same plane, the joints are said to be **in-phase** (Figure 6-16).



SERVICE TIP: On a two-piece drive shaft, you may encounter problems if you are not careful. The center U-joint must be disassembled to replace the center support bearing. The center driving yoke is splined to the front drive shaft. If the yoke's position on the drive shaft is not indicated in some manner, the yoke could be installed in a position that is out of phase. Manufacturers use different methods of indexing the yoke to the shaft. Some use aligning arrows. Others machine a master spline that is wider than the others. When there are no indexing marks, the technician should always index the yoke to the drive shaft before disassembling the U-joint. This saves time and frustration during reassembly. Indexing requires only a light hammer and center punch to mark the yoke and drive shaft.

Canceling Angles

Oscillations, resulting from speed variations, can be reduced by using **canceling angles** (Figure 6-17). The operating angle of the front U-joint is offset by the one at the rear of the drive shaft. When the front U-joint accelerates, causing a vibration, the rear U-joint decelerates causing an equal but opposite vibration. These vibrations created by the two joints oppose each other and dampen the vibrations from one to the other. The use of canceling angles provides smooth drive shaft operation.

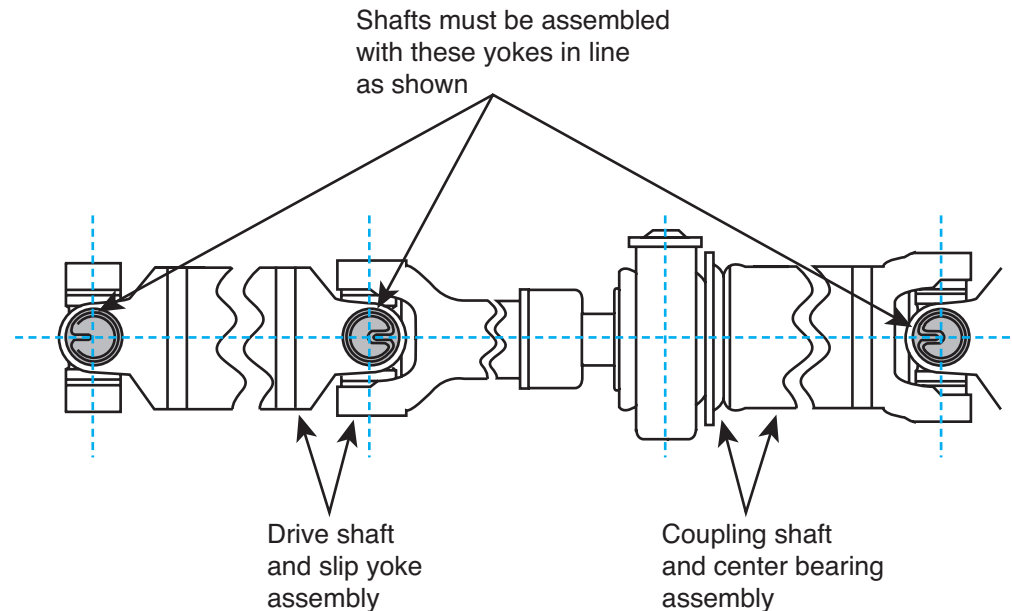

Figure 6-16 The U-joints are in the same plane and are in phase with each other.

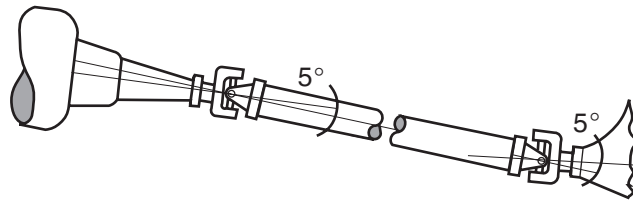

Figure 6-17 Equal U-joint angles reduce the vibrations of the shaft.

The correct operating angle of a U-joint must be maintained in order to prevent driveline vibration and damage. Shimming of leaf springs and the control arms on coil spring suspensions or adjusting the control arm eccentrics allow the operating angle of the drive shaft to be changed. Shimming at the transmission mount can also be done on some vehicles to change Universal joint angles.

Types of Universal Joints

There are three common designs of Universal joints: single Universal joints retained by either an inside or outside snapping, coupled Universal joints, (commonly called **double Cardan CV joints**) and Universal joints held in the yoke by U-bolts or lock plates.

Single Universal Joints

The single **Cardan/Spicer Universal joint's** (Figure 6-18) primary purpose is to connect the two yokes that are attached directly to the drive shaft. The joint assembly forms a cross, with four machined trunnions or points equally spaced around the center of the axis. Needle bearings used to reduce friction and provide smoother operation are set into bearing cups. The trunnions of the cross fit into the cup assemblies, which fit snugly into the driving and driven Universal joint yokes. U-joint movement takes place between the trunnions, needle bearings, and bearing cups. There should be no movement between the bearing cup and its bore in the Universal joint yoke. The bearings are usually held in place by snaprings that drop into grooves in the yoke's bearing bores. The bearing caps allow free movement between the trunnion and yoke. The needle bearing caps also may be pressed into the yokes, bolted to the yokes, or held in place with U-bolts or metal straps.

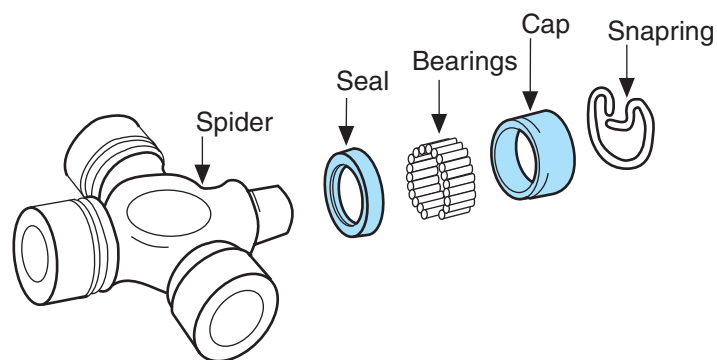

Figure 6-18 A Cardan U-joint.



Shop Manual

Chapter 6, page 241

Coupled Universal joints are commonly called **double Cardan CV joints**. A Double Cardan CV joint is actually two Cardan joints joined together by a yoke. By joining the two Cardan joints, rotational speed is not changed as the joint moves through its operating angles.

The **Cardan/Spicer Universal joint** is also known as the cross or four-point joint. Its primary purpose is to connect the two yokes that are attached directly to the drive shaft.

SERVICE TIP: There are many other methods used to retain the U-joint in its yoke, such as the use of a bearing plate, thrust plate, wing bearing, cap and bolt, U-bolt, and strap (Figure 6-19).

There are other styles of single Universal joints. The method used to retain the bearing caps is the major difference between these designs. The Spicer style uses an outside snapping that fits into a groove machined in the outer end of the yoke (Figure 6-20). The bearing cups for this style are machined to accommodate the snapping.

The mechanics style uses an inside snapping or C-clip that fits into a groove machined in the bearing cup on the side closest to the grease seal (Figure 6-21). When installed, the clip rests against the machined portion of the yoke. The snaprings are retained by spring tension against the retaining ring grooves. Some joints have nylon injected above the bearing cap to retain it. The nylon is heated to remove the joint.

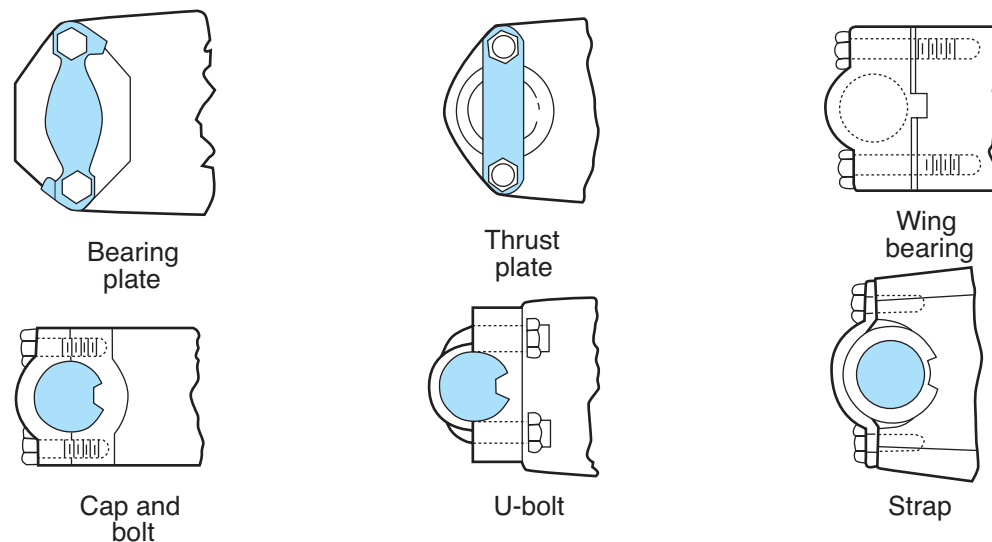

Figure 6-19 Various methods used to retain U-joints in their yokes.

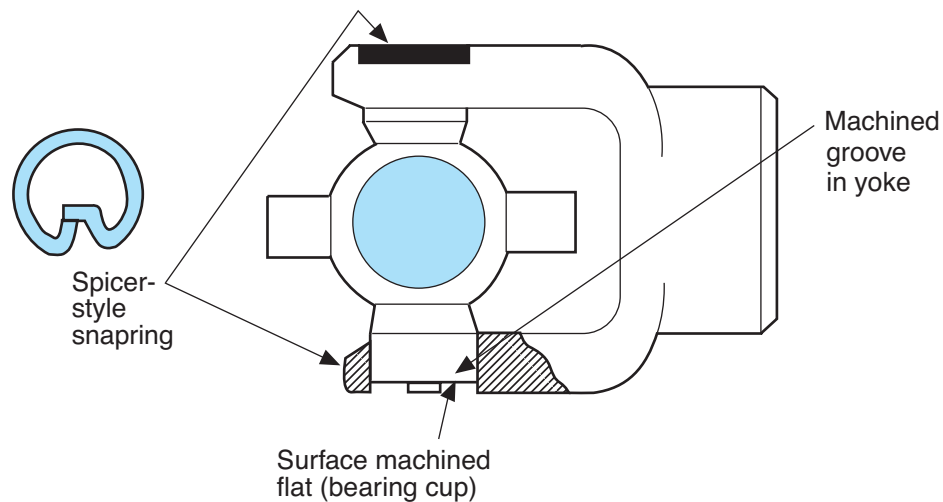

Figure 6-20 Spicer-style U-joint.

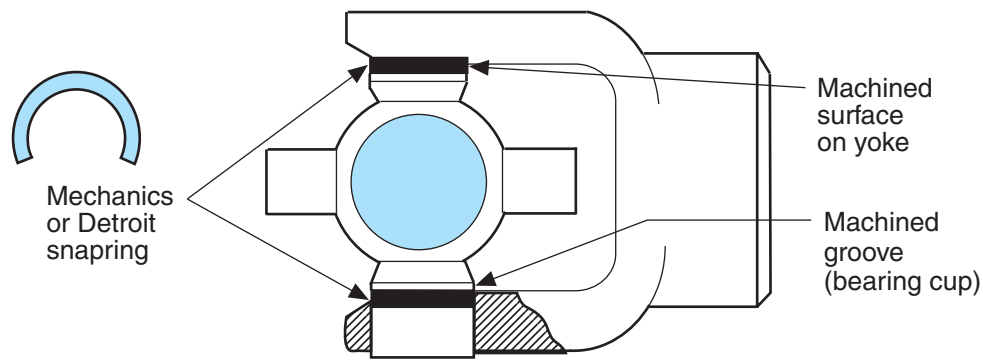

Figure 6-21 Mechanics-style U-joint.

The Cleveland style is an attempt to combine styles of Universal joints to obtain more applications from one joint. The bearing cups for this U-joint are machined to accommodate either Spicer- or mechanics-style snaprings. If a replacement U-joint comes with both style clips, use the clips that pertain to your application.

SERVICE TIP: In order to get the correct parts, you should know the type of U-joint and the yoke span originally installed in the car (Figure 6-22).

Double Cardan Universal Joint

A double Cardan U-joint is used with split drive shafts and consists of two individual Cardan U-joints closely connected by a centering socket yoke and a center yoke that functions like a ball and socket. The ball and socket splits the angle of two drive shafts between two U-joints (Figure 6-23). Because of the centering socket yoke, the total operating angle is divided equally between the two joints. Because the two joints operate at the same angle, the normal fluctuations that result from the use of a single U-joint are canceled out. The acceleration or deceleration of one joint is canceled by the equal and opposite action of the other.

Most often installed in front-engined rear-wheel-drive luxury cars, the double Cardan Universal joint smoothly transmits torque regardless of the operating angle of the driving and driven members. It is therefore classified as a CV Universal joint (Figure 6-24). This joint is used when the U-joint operating angle is too large for a single joint to handle. On some vehicles, the double joint is used at both ends of the drive shaft. On other vehicles, it is used only on the drive end of the drive shaft.

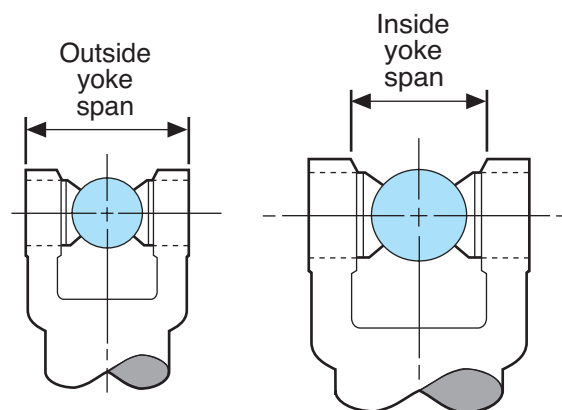

Figure 6-22 You should know both the outside (A) and inside (B) yoke span when ordering a new joint.

The mechanics-style U-joint is also called the Detroit/Saginaw style.



Shop Manual

Chapter 6, page 246

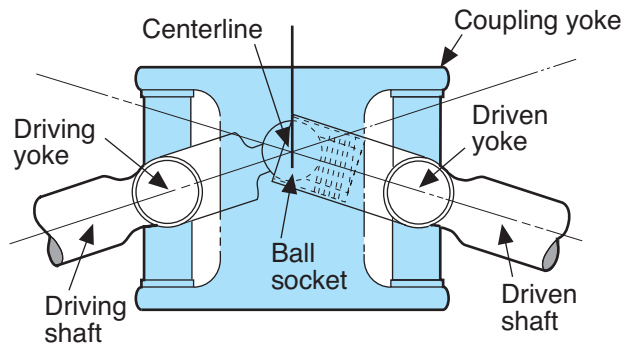

Figure 6-23 The ball and socket of a double Cardan joint splits the angle of the two shafts.

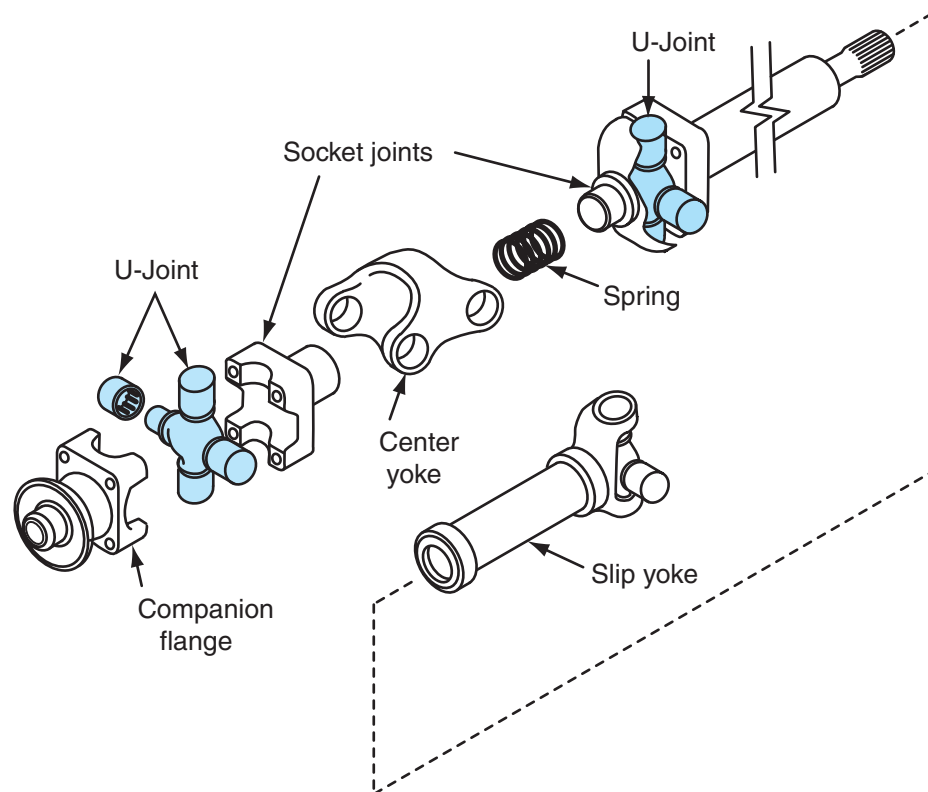

Figure 6-24 A double Cardan joint disassembled.

Constant Velocity Joints

CV joints are primarily used on FWD drive axles; however, some RWD cars with IRS—such as Ford Thunderbird, Corvette, BMW, and Porsche—use them. The commonly used types of CV joints are the Rzeppa and the tripod.



Shop Manual
Chapter 6, page 237

Slip Joints

As well as being equipped with universal joints to allow for angle changes, a drive shaft also must be able to change its effective length. As road surfaces change, the drive axle assembly moves up and down with the rear suspension. Because the transmission is mounted to the frame, it does not move with the movement of the suspension and the relative distance between the transmission

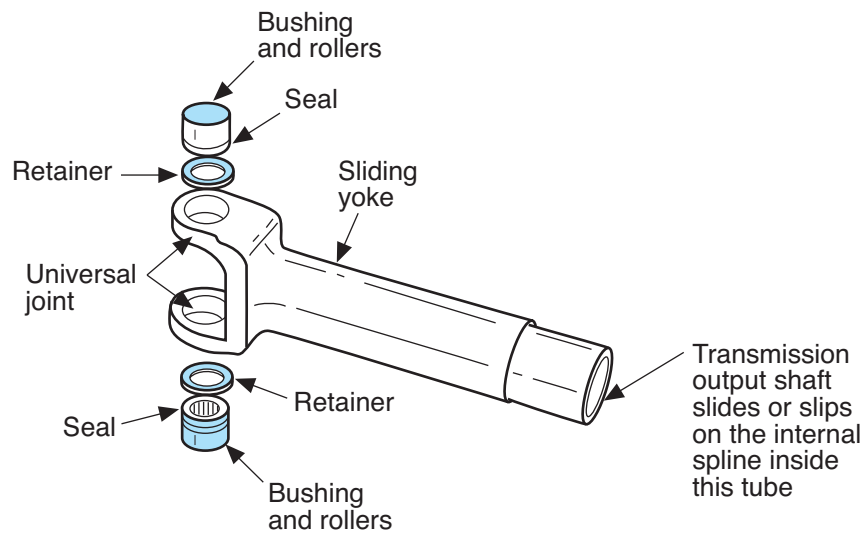

Figure 6-25 Typical slip joint assembly.

and rear drive axle changes. Drive shafts use a **slip joint** at one end of the drive shaft, which allows it to lengthen or shorten. The purpose of the slip joint is similar to the plunging CV joint used in FWD cars. The slip yoke is either positioned at the center of two-piece designs or at either end of the drive shaft, but is typically fitted to the front U-joint.

A slip joint assembly (Figure 6-25) includes the transmission's output shaft, the slip joint itself, a yoke, U-joint, and the drive shaft. The output shaft has external splines that match the internal splines of the slip joint. The meshing of the splines allows the two shafts to rotate together, but permits the ends of the shafts to slide along each other. This sliding motion allows for an effective change in the length of the drive shaft, as the drive axles move toward or away from the car's frame. The yoke of the slip joint is connected to the drive shaft by a U-joint.

Center Support Bearings

Vehicles with a long wheelbase are equipped with a propeller shaft that extends from the transmission or transfer case to a center support bearing (Figure 6-26) and they also have a propeller shaft that extends from the center support bearing to the rear axle. The center support bearing maintains the alignment of the two pieces. Pickup trucks and large SUVs commonly use a center support bearing.

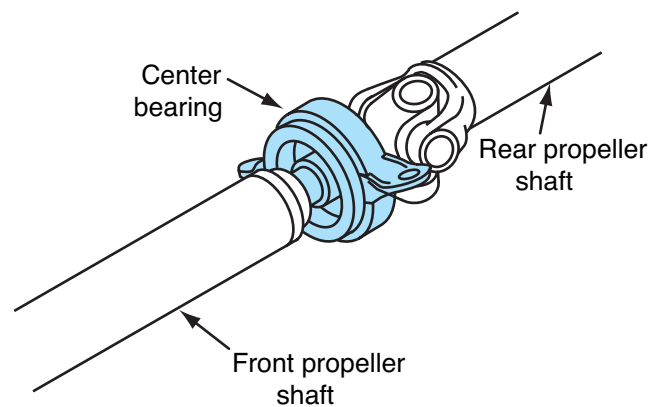

Figure 6-26 A center support bearing assembly.

A **slip joint** is a variable length connection that permits the drive shaft to change its effective length.

Some drive shafts are equipped with plunging-type CV joints in place of slip and universal joints.

A slip yoke is also called a sliding yoke.

In a center support bearing, a sealed ball or roller bearing allows the drive shaft to spin freely. The bearing is encased in rubber, or similar material, and the assembly is secured to a cross member of the frame or underbody. The rubber mount prevents noise and vibration from transferring into the passenger compartment of the vehicle.

The standard bearing is prelubricated and sealed and requires no further lubrication; however, some support bearings on heavy-duty vehicles have lubrication fittings.

Magneto-Rheological Fluid Center Bearing Brackets

MR fluid is a synthetic oil with soft magnetic particles, such as iron, suspended in it.

In an attempt to reduce vibrations set up by the drive shaft as it revolves in the center bearing, manufacturers are beginning to use **magneto-rheological (MR) fluid** in the mount. The MR fluid is used to change the stiffness of the mount when the vehicle is moving. In the presence of a magnetic field, MR fluids rapidly change their viscosity. The fluid becomes more viscous when the intensity of the magnetic field is increased; therefore, the mount becomes more rigid. To provide vibration isolation, a bracket with a very soft material, such as elastomer, is used in conjunction with the fluid's damping capability. This allows drive shaft vibrations to be dampened and isolated during all operating conditions, while keeping the drive shaft pieces securely aligned.

Summary

Terms to Know

Canceling angles

Cardan/Spicer

Universal joint

Double Cardan CV joint

Drive shaft

Ellipse

Hotchkiss drive

In-phase

Installation angle

Magneto-rheological (MR) fluid

Operating angle

Slip joint

Torque tube

Yoke

- ❑ A drive shaft is normally made from seamless steel tubing with Universal joint yokes fastened to each end.
- ❑ U-joints are used to allow the angle and the effective length of the drive shaft to change.
- ❑ A drive shaft is actually no more than a flexible extension of the transmission's output shaft.
- ❑ Yokes on the drive shaft provide a means of connecting the shafts together.
- ❑ Balance weights are welded to the outside of a drive shaft to balance it and reduce its natural vibrations.
- ❑ Some drive shafts are internally lined with cardboard or cardboard with rubber inserts to help offset torsional vibration problems.
- ❑ A Hotchkiss drive system has an external drive shaft with at least two Universal joints.
- ❑ A torque tube consists of a tubular steel or small diameter solid shaft enclosed in a larger steel tube and is rigidly connected to the rear axle housing.
- ❑ The operating angle of a Universal joint is determined by the installation angles of the transmission and rear axle assembly.
- ❑ U-joints vibrate if the connecting shafts are not on the same plane because one shaft will be accelerating and decelerating at different speeds than the other.
- ❑ Drive shaft vibrations can be reduced by using canceling angles. The operating angle of the front joint is offset by the angle of the rear joint.
- ❑ Speed fluctuations can be canceled if the driven yoke has the same point of rotation, or same plane, as the driving yoke. When the two yokes are in the same plane, the joints are said to be in-phase.
- ❑ There are three common designs of Universal joints: single U-joints retained by either an inside or outside snapping, coupled U-joints, and U-joints held in the yoke by U-bolts or lock plates.

- ❑ A single Cardan joint, the most common type of joint, uses a spider, four machined trunnions, needle bearings, and bearing caps to allow the transmission of power through slight shaft angle changes.
- ❑ A double Cardan joint is called a CV joint because shaft speeds do not fluctuate, regardless of the shaft's angle. These joints are used on two-piece shaft assemblies and are actually two single Cardan joints joined together by a center bearing assembly.
- ❑ The methods used to retain a U-joint in its yoke are the use of a snapping, C-clip, bearing plate, thrust plate, wing bearing, cap and bolt, U-bolt, and/or strap.
- ❑ A center support bearing is used on all two-piece drive shaft.

Review Questions

Short Answer Essays

1. State the purposes of a Universal joint.
2. What methods are used by some auto manufacturers to reduce drive shaft torsional vibration problems?
3. What determines the operating angle of a Universal joint?
4. Explain why and when U-joints vibrate.
5. What effect do in-phase Universal joints have on the operation of a drive shaft?
6. What is meant by canceling angles?
7. Describe the construction and operation of a single Cardan joint.
8. Describe the construction and operation of a double Cardan joint.
9. Why are some cars equipped with a two-piece drive shaft?
10. What methods are used to retain a U-joint in its yoke?

Fill-in-the-Blanks

1. A drive shaft is normally made from _____ tubing with _____ fastened to each end.
2. A drive shaft is actually an extension of the transmission's _____.
3. _____ on the drive shaft provide a means of connecting the shafts together.
4. _____ are welded to the outside of a drive shaft to _____ it and reduce its natural _____.
5. A slip joint is normally fitted to the _____.
6. A Hotchkiss drive system has an external _____ with at least _____ Universal joints.

the transmission's output shaft by a snapping.
Who is correct?

- A.** A only **C.** Both A and B
B. B only **D.** Neither A nor B

9. When discussing double Cardan joints, *Technician A* says that they are actually two single Cardan joints assembled together at a center bearing support. *Technician B* says that they are considered CV joints. Who is correct?

- A.** A only **C.** Both A and B
B. B only **D.** Neither A nor B

10. *Technician A* says that excessive joint operating angles can cause an increase in shaft vibration. *Technician B* says that a drive shaft will vibrate when the vehicle is driven at high speeds.

Who is correct?

- A.** A only **C.** Both A and B
B. B only **D.** Neither A nor B

