

## Locks & Alarms

### CHILD-PROOF LOCKS

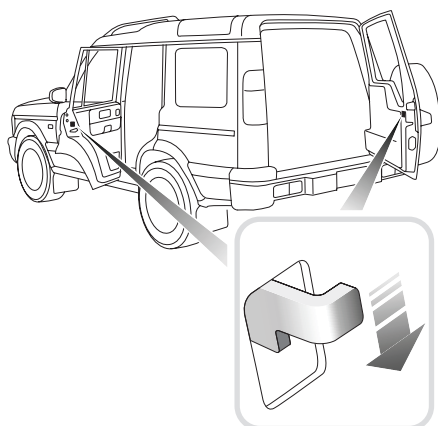

H4405

Move the locking levers on the rear doors and taildoor down to engage the child locks.

With the child-proof locks engaged, neither the rear doors nor the taildoor can be opened from inside the vehicle, thereby avoiding the risk of a door being opened accidentally while the vehicle is moving.

#### **WARNING**

***TO AVOID INJURY OR DEATH, NEVER LEAVE CHILDREN UNSUPERVISED IN THE VEHICLE.***

### DOOR LOCKING CUT-OFF SWITCH

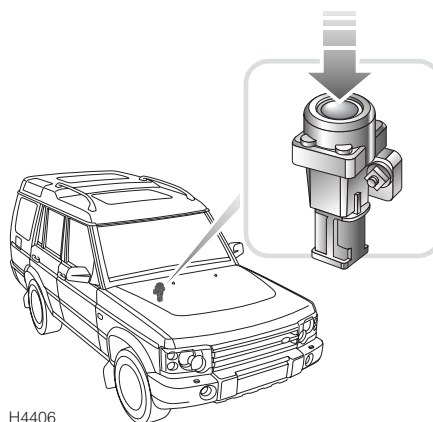

H4406

An inertia switch, operational only with the starter switch in position 'II' and the alarm disarmed, prevents the doors centrally locking (or if the doors are locked, will unlock them) in the event of an accident or sudden impact.

When the switch operates, the direction indicator lights flash (if market permits), until the system is reset by turning the starter switch on and off, and opening and closing the driver's door.

Note that doors cannot be locked again until the switch is reset. The inertia switch also cuts off the fuel supply (see 'FUEL CUT-OFF SWITCH', page 123).

#### **WARNING**

***Always check for fuel leaks before resetting the switch!***

***Activating the switch when the fuel system has been damaged (evidenced by fuel leakage or fuel odor) will cause additional fuel leakage increasing the risk of fire and personal injury.***