



Thermostat Monitoring									
Component/ System	Fault Codes	Monitoring Strategy Description	Malfunction Criteria	Threshold Value	Secondary Parameter	Enable Conditions	Time Required	MIL Illumination	
Thermostat stuck open	P0126	engine not fully warm and temperature drop across the radiator less than a threshold	engine coolant temperature - radiator outlet temperature (TKA)	m 45°C @ -10 °C TKA m 40 °C @ 0 °C TKA m 45 °C @ 10 °C TKA m 30 °C @ 20 °C TKA m 30 °C @ 30 °C TKA m 25 °C @ 40 °C TKA m 25 °C @ 50 °C TKA m 25 °C @ 60 °C TKA	ECT sensor plausibility test ECT time after Start engine Speed vehicle Speed ORFCO engine State airflow after start ECT at start transfer Gears	complete < 81.75 °C > from 220 sec @ 40 °C TKA to 270 sec @ -10 °C TKA > 400 rpm > 15.54 mph not True not Idle - from 3.0 kg @ 40 °C TKA to 10.0 kg @ -10 °C TKA -9.75 °C m start temperature m 81.75°C high Range	1.0 sec/ continuous	two driving cycles	
Radiator Outlet Temperature Sensor	P1118	circuit continuity range check (max)	voltage resistance	> 140.25 °C			1.0 sec/ continuous	two driving cycles	
	P1117	range check (min)		< -33.0 °C	intake air temperature	> -32.25 °C			
Engine Coolant Temperature Sensor High Sided Rationality Check Range Rover Only	P0116	checks for higher than expected engine temperature. Potential fault determined by the Power	<u>power up check</u> engine coolant temperature at start	> ECT at stop - (50.25 x Factor)	radiator outlet temperature at start absolute value of (radiator outlet temperature at start - intake air temperature at start) time after start	< 39.75 °C < 9.75 °C < 2.0 s	7.54 sec/ continuous	two driving cycles	
				intake air temp at start					factor
				-30 °C -15 °C 0 °C					0.9961 0.9727 0.9492



Thermostat Monitoring									
Component/ System	Fault Codes	Monitoring Strategy Description	Malfunction Criteria	Threshold Value		Secondary Parameter	Enable Conditions	Time Required	MIL Illumination
		up check at engine start and confirmed by driving check		10 °C	0.9180	radiator outlet temperature at stop ECT at stop transfer gears	> -9.75 °C		
				15 °C	0.8984				
				20 °C	0.8789		high range		
				25 °C	0.8477				
				30 °C	0.8203				
				35 °C	0.8516				
				45 °C	0.7617				
				55 °C	0.6758				
				65 °C	0.3008				
			<u>driving check</u> engine coolant temperature	> 102.0 °C		engine load engine speed calculated ECT vehicle speed time after start intake air temperature radiator outlet temperature transfer gears	2.0 < TL msec < 4.0 1200 < rpm < 2120 ~60.0 °C ~40 km/h > 290 sec m60 °C m55.5 °C high range		

If the above table does not include details of the following enabling conditions: - IAT, ECT, vehicle speed range, and time after engine start-up then the state of these parameters has no influence upon the execution of the monitor.

4.9 Engine Speed and Position Sensor (Crankshaft Sensor)

4.9.1 Description

This sensor is the most important sensor on the vehicle, without it the engine cannot run. There is no backup strategy or limp home facility should it fail. The sensor produces the signal which enables the ECM to determine the angle of the crankshaft, and the engine rpm. From this, the point of ignition, fuel injection, etc. is calculated. If the signal wires are reversed a 3° advance in timing will occur, as the electronics within the ECM uses the falling edge of the signal waveform as its reference/timing point for each tooth.

The reluctor is machined and has a tooth pattern based on 60 teeth at 6° intervals and 3° wide: two of the teeth are removed to provide a hardware reference mark which is 60 degrees before top dead centre No. 1 cylinder.

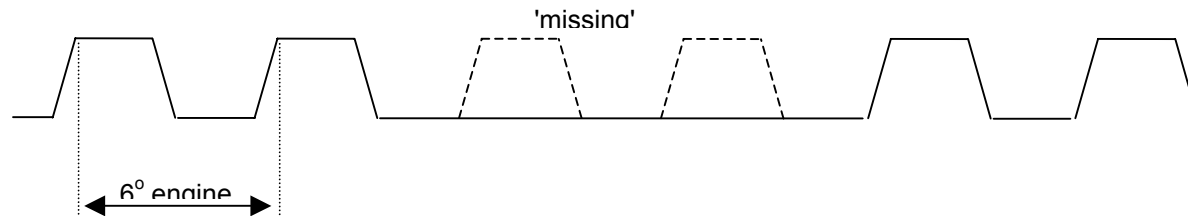

The sensor operates by generating an output voltage caused by the change in magnetic field, which occurs as the teeth pass in front of the sensor. The output voltage varies with the speed of the teeth passing the sensor; the higher the engine speed, the higher the output voltage. Note that the output is also dependent on the air gap between the sensor and the teeth (the larger the gap, the weaker the signal, the lower the output voltage).

There are two diagnostic checks on the output signal of this sensor: -

1. The hardware reference mark created by the missing teeth is outside the search window and the engine speed is greater than 500 rpm.
2. The hardware reference mark is outside the search window by more than one tooth and the engine speed is greater than 500 rpm.



The ECM transmits the engine speed to the automatic TCM using CAN, while all other control modules are hardwired.

Engine Speed and Position Sensor								
Component/ System	Fault Codes	Monitoring Strategy Description	Malfunction Criteria	Threshold value	Secondary Parameter	Enable Conditions	Time Required	MIL Illumination
Engine Speed and Position Sensor	P0335	rationality check	reference mark outside search window	> 2 occurrences	engine speed	> 500 rpm	2 revolutions/continuous	two driving cycles
	P0336		counted teeth – actual number of teeth	+ 1 tooth			1 revolution/continuous	

If the above table does not include details of the following enabling conditions: - IAT, ECT, vehicle speed range, and time after engine start-up then the state of these parameters has no influence upon the execution of the monitor.

4.10 Camshaft Position Sensor

4.10.1 Description

This is a Hall effect sensor producing four pulses for every two engine revolutions. The sensing element is positioned between 0 and 2mm from the side of the cam gear wheel. The sensor is, in effect, a magnetically operated electrical switch, switching a battery supply level voltage on or off dependent on the position of the cam gear wheel with respect to the sensor.

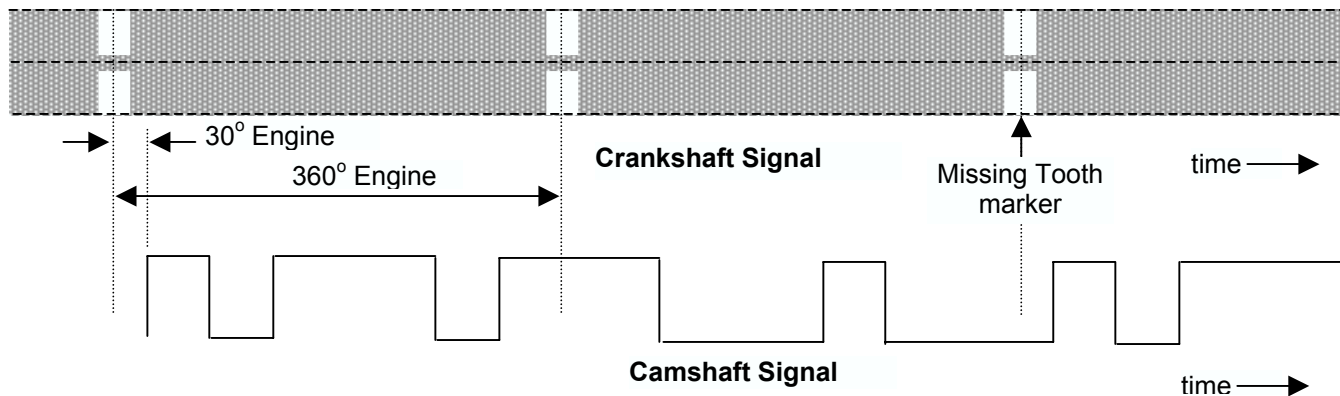

The cam gear wheel has four slots machined in it enabling cylinder identification every 90°. The signal is used for cylinder recognition; enabling sequential fuel injection, knock control and cylinder identification for diagnostic purposes.

The system checks the camshaft position sensor signal at every software reference mark i.e., 54° before top dead centre (2 teeth after the reluctor 2nd missing tooth). A fault condition is recognised if the signal does not change state (high to low or low to high voltage) every crankshaft revolution.

Camshaft Position Sensor								
Component/System	Fault Codes	Monitoring Strategy Description	Malfunction Criteria	Threshold value	Secondary Parameter	Enable Conditions	Time Required	MIL Illumination
Camshaft Position Sensor	P0340	rationality check	signal sequence	incorrect signal	crankshaft revolutions	> 100 revolutions	0.500 sec/continuous	two driving cycles

If the above table does not include details of the following enabling conditions: - IAT, ECT, vehicle speed range, and time after engine start-up then the state of these parameters has no influence upon the execution of the monitor.



4.11 Engine Coolant Temperature Sensor

4.11.1 Description

This sensor is a temperature dependant resistor (thermistor), which is a Negative Temperature Co-efficient (NTC) type, i.e. resistance decreases with increasing temperature. The sensor forms part of a voltage divider chain with a pull up resistor within the ECM. The change in resistance relates to change in the ECT.

The sensor is vital to the correct running of the engine as a richer mixture is required at lower block temperatures for good quality starts and smooth running, leaning off as the temperature rises to maintain emissions and performance. Should the sensor fail there is a software ECT warm-up model which will supply a changing default value during the warm up stage of the engine, based upon IAT. After the software model reaches 60°C ECT, a fixed default value of 85°C is used. The model also forms part of the diagnostics for the ECT sensor, in conjunction with open and short circuit tests.

A fault condition is recognised if the ECM is powered up and the ECT sensor resistance exceeds a minimum or maximum threshold, or the difference between the ECT model and the temperature indicated by the ECT sensor is greater than a threshold.

Engine Coolant Temperature Sensor								
Component/ System	Fault Codes	Monitoring Strategy Description	Malfunction Criteria	Threshold Value	Secondary Parameter	Enable Conditions	Time Required	MIL Illumination
Engine Coolant Temperature Sensor	P0117	circuit continuity range check (min)	voltage resistance	> 34.166 k Ω (-35.25°C)			0.180 sec/ continuous	two driving cycles
	P0118	range check (max)		< 70.96 Ω (139.5°C)				
	P0116	rationality check (temperature model = f [IAT, air mass, time])	difference to model temperature	> -20.25°C			2.54 sec/ continuous	

If the above table does not include details of the following enabling conditions: - IAT, ECT, vehicle speed range, and time after engine start-up then the state of these parameters has no influence upon the execution of the monitor.



4.12 Mass Airflow Sensor and Intake Air Temperature Sensor

The MAF sensor is a combined MAF sensor and IAT sensor.

4.12.1 Mass Airflow Sensor

4.12.2 Description

Airflow is determined by the cooling effect of the intake air passing over a “hot film” element contained within the device. The higher the air flow the greater the cooling effect and the lower the electrical resistance of the “hot film” element. The signal from the device is then used by the ECM to calculate the MAF into the engine.

The measured airflow is used in determining the fuel quantity to be injected in order to maintain the stoichiometric air fuel ratio required for correct operation of the engine and exhaust catalysts. Should the device fail there is a software backup strategy that will be evoked once a fault has been diagnosed. A fault is detected if the MAF signal exceeds the maximum or minimum threshold for a given speed range or the difference between the calculated load and the actual MAF signal is too great.

Mass Airflow Sensor								
Component/ System	Fault Codes	Monitoring Strategy Description	Malfunction Criteria	Threshold value	Secondary Parameter	Enable Conditions	Time Required	MIL Illumination
Mass Airflow Sensor	P0102	range check (min)	air flow verses engine Speed	<2.43 g/sec(@ 800 rpm) To 8.96 g/sec(@ 5000 rpm)	engine speed	> 400 rpm > 200 rpm (for > 0.3 sec)	0.5 sec/ continuous	two driving cycles
	P0103	range check (max)	4.0 litre 4.6 litre	>40.0g/sec to 224.5g/sec > 46.7g/sec to 248.9g/sec (1000 RPM to 5400 rpm)		> 200 rpm (for > 0.3 sec)	0.3 sec/ continuous	
	P0101	rationality check (low/high)	comparison of calculated load (engine speed and throttle position) to actual MAF signal	adaptation factor (af) $1.5 < af < 0.35$	engine speed engine load ECT	$800 < rpm < 4000$ $2 < TL \text{ msec} < 6.5$ $> -9.75^\circ \text{ C}$	immediately/ continuous	

If the above table does not include details of the following enabling conditions: - IAT, ECT, vehicle speed range, and time after engine start-up then the state of these parameters has no influence upon the execution of the monitor.



4.12.3 Intake Air Temperature Sensor

4.12.4 Description

The IAT sensor is a temperature dependent resistor (thermistor), i.e. the resistance of the sensor varies with temperature. The thermistor is an NTC type element, which means that the sensor resistance decreases as the sensor temperature increases. The sensor forms part of a voltage divider chain with an additional resistor in the ECM. The voltage from this network changes as the sensor resistance changes, relating the IAT to the voltage measured by the ECM.

A fault is detected if the resistance of the sensor exceeds a minimum or maximum threshold.

Intake Air Temperature Sensor								
Component/ System	Fault Codes	Monitoring Strategy Description	Malfunction Criteria	Threshold value	Secondary Parameter	Enable Conditions	Time Required	MIL Illumination
Intake Air Temperature Sensor	P0113	circuit continuity range check (max)	voltage resistance	<82.7 δ (>139.5°C)			0.20 sec/ continuous	two driving cycles
	P0112	range check (min)		>29.9k δ (<-35.25°C)	time after start engine load fuel system status	> 180 sec idle not in ORFCO (all above for > 10 sec)		

If the above table does not include details of the following enabling conditions: - IAT, ECT, vehicle speed range, and time after engine start-up then the state of these parameters has no influence upon the execution of the monitor.



4.13 Knock Sensor

4.13.1 Description

The ECM uses active knock control, which serves to prevent engine damaging pre-ignition or detonation under all operating conditions enabling the engine to operate without additional safety margins. For the ECM to be able to determine the point at which a cylinder is pre-detonating, 2 piezo ceramic sensors are mounted on the engine block. Each sensor monitors all 4 cylinders in a bank (i.e. cylinders 1, 3, 5 & 7, and cylinders 2, 4, 6 and 8) by converting the engine block noise into a suitable electrical signal, which is then transmitted back to the ECM via a shielded cable. The signal is then processed within the ECM to identify the data that characterises knocking.

There are three knock sensor diagnostic checks during which a fault is detected if: -

1. The sensor signal is less than the minimum engine rpm dependant threshold.
2. The sensor signal is greater than the maximum engine rpm dependant threshold.
3. The error counter for the verification of knock internal circuitry is exceeded.

Knock Sensor								
Component/ System	Fault Codes	Monitoring Strategy Description	Malfunction Criteria	Threshold Value	Secondary Parameter	Enable Conditions	Time Required	MIL Illumination
Knock Sensor Bank 1 Bank 2 Bank 1 Bank 2	P0327	sensor reference voltage check	sensor reference voltage (10 samples)	from <2.44 mV at 2000 rpm	knock control engine speed	active (for at least 50 engine revolutions) > 2200 rpm (and not changing dynamically)	approximately 20 engine revolutions/ continuous	No MIL illumination
	P0332			to <25.02mV at 5200 rpm				
	P0328			from >207.5mV at 2000 rpm				
	P0333			to >622.6mV at 5200 rpm				
	P0606	response to test Signal	integrator output (3 samples)	< 3.51V	ECT	> 60 °C	approximately 740 engine revolutions/ continuous	
	null test	integrator output (3 samples)	> 0.353V					
	OR	integrator change AND engine speed	> 45.5V/sec < 4200 rpm					

If the above table does not include details of the following enabling conditions: - IAT, ECT, vehicle speed range, and time after engine start-up then the state of these parameters has no influence upon the execution of the monitor.



4.14 Throttle Position Sensor

4.14.1 Description

The sensor is a variable resistor, which is used to determine the position of the throttle plate and the rate of change in its angle. A software strategy within the ECM enables the closed throttle position to be learnt, enabling the sensor to be fitted without the need for adjustment. The signal is used by the ECM as part of the transient fuelling strategy and to determine the closed throttle position for idle speed control, in conjunction with road speed.

The signal is not only checked for range (exceeds a minimum or maximum threshold), but also for plausibility against MAF. If the load-monitoring fault is stored, it is indicative of a blocked air filter or collapsed air intake duct etc. It is also probable that the altitude adaptation factor is incorrect under these conditions.

Throttle Position Sensor								
Component/ System	Fault Codes	Monitoring Strategy Description	Malfunction Criteria	Threshold value	Secondary Parameter	Enable Conditions	Time Required	MIL Illumination
Throttle Position Sensor	P0122	range check (min)	voltage	< 0.195V (3.9%)	engine speed	> 400 rpm (for > 2.0 sec)	0.05 sec/ continuous	two driving cycles
	P0123	range check (max)		> 4.83V (96%)				
	P0101	rationality check (low/high)	comparison of calculated load (engine speed and throttle position) to actual MAF signal	adaptation factor 1.5 < af < 0.35	engine speed engine load ECT	800 < rpm < 4000 2.0 < TL msec < 6.5 > -9.75° C	immediately/ continuous	

If the above table does not include details of the following enabling conditions: - IAT, ECT, vehicle speed range, and time after engine start-up then the state of these parameters has no influence upon the execution of the monitor.



4.15 Engine Control Module Self Test

4.15.1 Description

The ECM performs a number of self-test integrity diagnostics on its internal hardware and software to check for faults. An error is detected if the ECM receives no CAN messages for at least 0.8 seconds, the calculated checksums at power down do not match the values stored in flash Electrically Erasable Programmable Read Only Memory (EEPROM) or the internal or external RAM fails a read/write test.

Engine Control Module Self Test								
Component/ System	Fault Codes	Monitoring Strategy Description	Malfunction Criteria	Threshold value	Secondary Parameter	Enable Conditions	Time Required	MIL Illumination
ECM	P0600	bus check	no CAN messages	> 0.800 sec			immediately/ continuous	two driving cycles
	P0601	self check of ROM contents	invalid checksum		at power down		0.20/0.30 sec	
	P0603	external RAM check	fails read/write test					
	P0604	internal RAM check	fails read/write test		at power up			

If the above table does not include details of the following enabling conditions: - IAT, ECT, vehicle speed range, and time after engine start-up then the state of these parameters has no influence upon the execution of the monitor.



4.16 Fuel Level Sensor

4.16.1 Description

This input is required as part of the misfire detection system in order to record if a 'low fuel' situation was present when misfire was detected and logged as a fault. On Range Rover 38A the ECM is required to read an analogue fuel level input and determine the 'low fuel' condition from this signal. Discovery Series II had an active high digital input until 2000MY, at which point this input also became an analogue signal.

There are three fuel level input diagnostic checks, during which a fault is detected if: -

1. The input signal is less than a minimum voltage threshold.
2. The input signal is greater than a maximum voltage threshold.
3. The percentage difference between the fuel consumption calculated by the ECM and the change in the fuel tank level is greater than a threshold.

Fuel Level Sensor								
Component/ System	Fault Codes	Monitoring Strategy Description	Malfunction Criteria	Threshold value	Secondary Parameter	Enable Conditions	Time Required	MIL Illumination
Fuel Level Sensor	P0460	rationality check between the fuel consumption calculated by the ECM and the change in fuel tank level	calculated fuel consumption - change in fuel tank level	< -21.5% or > 20.4% (37.6% if tank full, which is defined as tank level > 91.4%)	total fuel used distance traveled transfer gears	> 21.5% > 0.62 miles high range	immediately/ continuous	no MIL illumination (leak detection defaults to enabled)
	P0462	range check (min)	voltage	< 0.49V			10.0 sec/	
	P0463	range check (max)		> 4.294V			continuous	

If the above table does not include details of the following enabling conditions: - IAT, ECT, vehicle speed range, and time after engine start-up then the state of these parameters has no influence upon the execution of the monitor.



4.17 Vehicle Speed Signal

4.17.1 Description

The vehicle speed signal is transmitted from either the Self Levelling, Anti-lock Braking System (SLABS) or the ABS control module. This signal is then passed by the ECM to the automatic TCM via the CAN bus. The ECM has input diagnostics for this signal; the SLABS/ABS signal is compared to the vehicle speed signal on CAN from the automatic TCM, derived from the main gearbox output shaft speed; if the difference is greater than a threshold then a fault is detected.

Vehicle Speed Signal								
Component/ System	Fault Codes	Monitoring Strategy Description	Malfunction Criteria	Threshold value	Secondary Parameter	Enable Conditions	Time Required	MIL Illumination
Vehicle Speed Signal	P0501	plausibility check	difference to calculated speed	> 31.1 mph	vehicle speed	> 49.7 mph	10.0 sec/ continuous	two driving cycles

If the above table does not include details of the following enabling conditions: - IAT, ECT, vehicle speed range, and time after engine start-up then the state of these parameters has no influence upon the execution of the monitor.

4.18 Power Supplies

4.18.1 Description

The ECM requires a permanent battery level voltage supply and a switched battery level voltage supply. The switched voltage supply is controlled by the ECM via a relay based on the condition of the ignition switch input (key position 2). At "key off" the ECM will maintain the switched supply active until various internal self-checks have been completed.

There are three battery voltage plausibility checks during which a fault is detected if: -

1. The battery voltage supply is less than a minimum voltage threshold.
2. The battery voltage supply is greater than a maximum voltage threshold and a jump-start condition has not been detected.
3. The battery voltage supply is less than a voltage threshold 60 seconds after the engine has been started.

Battery Voltage								
Component/ System	Fault Codes	Monitoring Strategy Description	Malfunction Criteria	Threshold value	Secondary Parameter	Enable Conditions	Time Required	MIL Illumination
Battery Voltage	P0560	battery voltage plausibility checks	battery voltage	< 2.55V			immediately/ continuous	no MIL illumination
	P0562		battery voltage	< 9.05V	time since engine start	> 60.0 sec		
	P0563		battery voltage	> 16.03V	jump start (vehicle speed = 0 and voltage > 15.0V)	not detected		

If the above table does not include details of the following enabling conditions: - IAT, ECT, vehicle speed range, and time after engine start-up then the state of these parameters has no influence upon the execution of the monitor.



4.19 Rough Road signal

4.19.1 Description

The SLABS/ABS control module transmits a PWM signal indicating rough road for misfire detection disablement. The ECM has input diagnostics for this signal.

There are three plausibility checks of the PWM signal during which a fault is detected if: -

1. The PWM signal is greater than a threshold indicating an electrical short to battery positive.
2. The PWM signal is less than a threshold indicating an electrical short to ground.
3. The PWM signal is greater than 44.92% but less than 55.08% indicating an error with the SLABS/ABS control module.

Rough Road Signal								
Component/ System	Fault Codes	Monitoring Strategy Description	Malfunction Criteria	Threshold Value	Secondary Parameter	Enable Conditions	Time Required	MIL Illumination
Rough Road Signal	P1590	plausibility checking of the PWM signal from the anti- lock brake ECM	PWM signal	44.92 % < signal < 55.08 %	ignition engine state	on not starting	2.0 sec/ continuous	no MIL illumination (misfire defaults to enabled)
	P1591		PWM signal	signal < 10.16 %				
	P1592		PWM signal	signal > 89.84%				

If the above table does not include details of the following enabling conditions: - IAT, ECT, vehicle speed range, and time after engine start-up then the state of these parameters has no influence upon the execution of the monitor.

4.20 Transfer Box Malfunction Indicator Lamp Request (Range Rover 38A Only)

4.20.1 Description

This input indicates to the ECM that there is an OBD relevant error within the transfer box control module. The ECM will illuminate the MIL and store the P1701 DTC whenever this signal is true. The ECM carries out an integrity check on this signal following an 'ignition on' condition as shown below and detects a fault if any of the following conditions are satisfied: -

1. The line voltage is high during the low test.
2. The line voltage is low during the high test.
3. The line voltage is in an undefined state, neither high nor low.

Ignition on Integrity Check Waveform

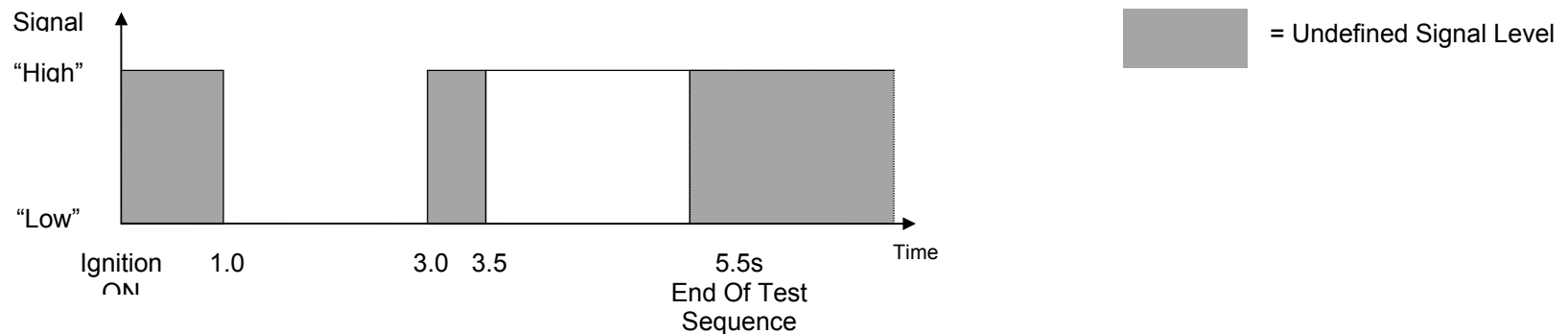



Transfer Box Malfunction Indicator Lamp Request

Component/ System	Fault Codes	Monitoring Strategy Description	Malfunction Criteria	Threshold value	Secondary Parameter	Enable Conditions	Time Required	MIL Illumination
Transfer Box Functionality (Range Rover Only)	P1701	MIL request from the transfer box control module			battery voltage	> 8.02V	5.5 sec/ continuous	two driving cycles
	P1702	plausibility checking of the link from the transfer box control module	line voltage	undefined state	ignition reset counter	On = 0	performed once at ignition on	
	P1703		line voltage	high during low test				
	P1708		line voltage	low during high test				

If the above table does not include details of the following enabling conditions: - IAT, ECT, vehicle speed range, and time after engine start-up then the state of these parameters has no influence upon the execution of the monitor.



4.21 Air Conditioning System (Discovery Series II Only)

4.21.1 Description

The air conditioning system comprises of the Heating and Ventilation Control (Air Conditioning) Module (HeVAC), the air conditioning compressor and the condenser fans. The ECM controls the compressor clutch via a relay.

The control strategy of the relay features hysteresis to avoid the compressor clutch cycling while the engine is running. When there is a need for the compressor to be activated, the HeVAC module sends a request signal to the ECM, which in turn activates the compressor clutch relay. The condenser fan relay is controlled separately by both the ECM and the HeVAC module, and again, the control strategy features hysteresis to avoid the cooling fans cycling while the engine is running and the engine coolant and/or condenser temperatures fluctuate around a given threshold. When there is a need for condenser cooling for air conditioning performance the HeVAC module sends a request signal to the condenser fan relay. If there is a requirement for condenser cooling due to ECT, the ECM will send the request signal to the condenser fan relay.

When the HeVAC module requests air conditioning, the signal it sends to the ECM is through two binary switches, which sense the minimum and maximum refrigerant pressure and an evaporator thermostat. If the pressure or the temperature is below or above certain levels the binary switches will be open circuit and effectively disable the A/C request line to the ECM, which in turn will disengage the compressor clutch.

The air conditioning system is in standby mode if the HeVAC module is on and economy mode is not selected.

There are four diagnostic checks of the air conditioning system during which a fault is detected if: -

1. The A/C compressor clutch relay short circuit to battery positive, i.e. the driver voltage is greater than half the battery voltage when the driver is on.
2. The A/C compressor clutch relay short circuit to ground, i.e. the driver voltage is less than one third of the battery voltage when the driver is off.
3. The A/C compressor clutch relay is open circuit, i.e. the driver voltage is greater than one third of the battery voltage but less than two thirds of the battery voltage when the driver is off.
4. A/C has been requested when the system is not in standby mode, i.e. a signal rationality check.



Air Conditioning System								
Component/ System	Fault Codes	Monitoring Strategy Description	Malfunction Criteria	Threshold Value	Secondary Parameter	Enable Conditions	Time Required	MIL Illumination
Air Conditioning System	P1538	circuit continuity - short to battery positive	voltage - drive on	voltage > 1/2 * Battery positive	battery voltage	7.5V < Battery positive < 17V	immediately/ continuous	no MIL illumination
	P1537	circuit continuity - short to ground	voltage - drive off	Voltage < 1/3 * Battery positive				
	P1536	circuit continuity -	voltage - drive off	1/3* Battery positive < voltage < 2/3* Battery positive	engine speed	> 80 rpm		
	P1535	open circuit signal rationality check	A/C requested when not in standby mode				0.5 sec	

If the above table does not include details of the following enabling conditions: - IAT, ECT, vehicle speed range, and time after engine start-up then the state of these parameters has no influence upon the execution of the monitor.

4.22 Fuel Injectors

4.22.1 Description

The engine is fitted with 8 fuel injectors (one per cylinder), each of which is directly driven by the ECM. The Injectors are fed from a common fuel rail as part of a return less fuel system, with the fuel rail pressure constant at 3.5 bar (52 psi). The Fuel Pressure Regulator is integral to the fuel pump module, within the fuel tank. There is no reference signal line to the intake manifold.

The ECM monitors the output power stages of the injector drivers for electrical faults. A fault is detected if any of the following conditions is satisfied: -

1. Fuel injector driver short circuit to battery positive, i.e. the driver voltage is greater than half the battery voltage when the driver is on.
2. Fuel injector driver short circuit to ground, i.e. the driver voltage is less than one third of the battery voltage when the driver is off.
3. Fuel injector driver open circuit, i.e. the driver voltage is greater than one third of the battery voltage but less than two thirds of the battery voltage when the driver is off.



Fuel Injectors								
Component/ System	Fault Codes	Monitoring Strategy Description	Malfunction Criteria	Threshold Value	Secondary Parameter	Enable Conditions	Time Required	MIL Illumination
Fuel Injector	P0201 to P0208	circuit continuity - open circuit	voltage - drive off	$1/3 * \text{Battery positive} < \text{voltage} < 2/3 * \text{Battery positive}$	engine speed battery voltage	$> 80 \text{ rpm}$ $7.5V < \text{Battery positive} < 17V$	immediately/ continuous	two driving cycles
	P0261/4/7 P0270/3/6 P0279/82	circuit continuity - short to ground.	voltage - drive off	$\text{voltage} < 1/3 * \text{Battery positive}$				
	P0262/5/8 P0271/4/7 P0280/3	circuit continuity - short to battery positive	voltage - drive on	$\text{voltage} > 1/2 * \text{Battery positive}$				

If the above table does not include details of the following enabling conditions: - IAT, ECT, vehicle speed range, and time after engine start-up then the state of these parameters has no influence upon the execution of the monitor.

4.23 Idle Speed Control Actuator

4.23.1 Description

The load on an idling engine is a combination of both internal and external engine loads such as engine friction, water pump, air conditioning etc., which all change with time and operating conditions. The idle speed control actuator is required to enable closed loop idle speed control to compensate for these changing conditions, by regulating the airflow into the engine.

The device consists of two coils which use opposing PWM signals to control the position of opening / closing of the rotary valve. If one circuit fails the other is switched off by the ECM as soon as it recognises the fault. This prevents the valve going to a maximum or minimum setting. There is a default position, which is determined by a permanent magnet. In the default condition the idle speed is raised and remains fixed at approximately 1200 rpm with no load.

There are eight idle speed control actuator diagnostic checks: -

1. Opening winding driver short circuit to battery positive, i.e. the driver voltage is greater than half the battery voltage when the driver is on.
2. Opening winding driver short circuit to ground, i.e. the driver voltage is less than one third of the battery voltage when the driver is off.
3. Opening winding driver open circuit, i.e. the driver voltage is greater than one third of the battery voltage but less than two thirds of the battery voltage when the driver is off.
4. Closing winding driver short circuit to battery positive, i.e. the driver voltage is greater than half the battery voltage when the driver is on.
5. Closing winding driver short circuit to ground, i.e. the driver voltage is less than one third of the battery voltage when the driver is off.
6. Closing winding driver open circuit, i.e. the driver voltage is greater than one third of the battery voltage but less than two thirds of the battery voltage when the driver is off.
7. Blocked Idle Air Control (IAC) valve – rpm error low, i.e. the engine speed is 100 rpm less than the target speed.
8. Blocked IAC valve – rpm error high, i.e. the engine speed is 180 rpm greater than the target speed.



Idle Air Control Valve								
Component/ System	Fault Codes	Monitoring Strategy Description	Malfunction Criteria	Threshold value	Secondary Parameter	Enable Conditions	Time Required	MIL Illumination
Idle Air Control Valve opening	P1510	circuit continuity - Open circuit	voltage - drive off	1/3 * Battery positive < voltage < 2/3 * Battery positive	engine speed	> 80 rpm	immediately/ continuous	two driving Cycles
	P1513	circuit continuity - short to ground	voltage - drive off	voltage < 1/3 * Battery positive	battery voltage	7.5V < Battery positive < 17V		
	P1514	circuit continuity - Short to battery positive	voltage - drive on	voltage > 1/2 * Battery positive				
	P1551	circuit continuity - open circuit	voltage - drive off	1/3 * Battery positive < voltage < 2/3 * Battery positive				
	P1552	circuit continuity - short to ground	voltage - drive off	voltage < 1/3 * Battery positive				
	P1553	circuit continuity - short to battery positive	voltage - drive on	voltage > 1/2 * Battery positive				
closing	P0505	functional check	actual - desired RPM	> +180 rpm < -100 rpm	vehicle speed ECT IAT altitude adaptation transfer gears engine load		= 0 mph > 80.25° C > -9.75° C > 0.712 high range < 2.5 m sec	2.0 to 3.0 sec/once per driving cycle

If the above table does not include details of the following enabling conditions: - IAT, ECT, vehicle speed range, and time after engine start-up then the state of these parameters has no influence upon the execution of the monitor.



4.24 Fuel Pump Relay

4.24.1 Description

The Land Rover V8 engine has a return-less fuel system. The fuel pressure regulator and filter are fitted to the 'in tank fuel pump module'. The system pressure is maintained at a constant 3.5 bar (52 Psi), with no reference to intake manifold pressure. The ECM compensates for the non-constant pressure drop across the injector nozzles.

The fuel is supplied to the injectors from a fuel pump fitted within the fuel tank. The electrical supply to this fuel pump is controlled by the ECM via a relay and an Inertia fuel shutoff switch, which will turn off the fuel supply upon vehicle impact. The fuel system is pressurised to 3.5 bar as soon as the ECM is powered up, the pump is then switched off until engine start has been achieved. If the pump runs but the fuel pressure is out of limits, adaptive fuel faults are stored.

The ECM monitors the output power stage of the fuel pump relay drive for electrical faults. A fault is detected if any of the following conditions is satisfied: -

1. Fuel pump relay driver short circuit to battery positive, i.e. the driver voltage is greater than half the battery voltage when the driver is on.
2. Fuel pump relay driver short circuit to ground, i.e. the driver voltage is less than one third of the battery voltage when the driver is off.
3. Fuel pump relay driver open circuit, i.e. the driver voltage is greater than one third of the battery voltage but less than two thirds of the battery voltage when the driver is off.

Fuel Pump Relay								
Component/ System	Fault Codes	Monitoring Strategy Description	Malfunction Criteria	Threshold value	Secondary Parameter	Enable Conditions	Time Required	MIL Illumination
Fuel Pump Relay	P1232	circuit continuity - short to battery positive	Voltage - drive on	voltage > 1/2 * Battery positive	battery voltage	7.5V < Battery positive < 17V	immediately/ continuous	no MIL illumination
	P1231	circuit continuity - short to ground	Voltage - drive off	voltage < 1/3 * Battery positive	engine speed	> 80 rpm		
	P1230	circuit continuity - open circuit	Voltage - drive off	1/3 * Battery positive < voltage < 2/3 * Battery positive	time after fuel pump off	> 0.5 sec		

If the above table does not include details of the following enabling conditions: - IAT, ECT, vehicle speed range, and time after engine start-up then the state of these parameters has no influence upon the execution of the monitor.



4.25 Malfunction Indicator Lamp

4.25.1 Description

The OBD system interfaces with the driver via the MIL, which is located in the instrument pack. A bulb check takes place every time the ignition is switched to ignition position II and until the engine is cranked.

The ECM monitors the driver junction temperature to detect an electrical fault. A fault is detected if the following condition is satisfied: -

1. MIL driver short circuit to battery positive, i.e. the driver stage junction temperature exceeds a temperature threshold.

Malfunction Indicator Lamp								
Component/ System	Fault Codes	Monitoring Strategy Description	Malfunction Criteria	Threshold value	Secondary Parameter	Enable Conditions	Time Required	MIL Illumination
Malfunction Indicator Lamp	P0650	short circuit to battery positive	drive stage junction temperature	> 150 °C	engine speed battery voltage	> 80 rpm 7.5V < Battery positive < 17V	immediately/ continuous	no MIL illumination

If the above table does not include details of the following enabling conditions: - IAT, ECT, vehicle speed range, and time after engine start-up then the state of these parameters has no influence upon the execution of the monitor.



4.26 Hill Descent Control Signal – Discovery Series II Only

4.26.1 Description

HDC operates in conjunction with the anti-lock braking system to provide greater control in off-road situations if necessary. HDC can be selected with the vehicle in any gear, but will only operate when low range gears are engaged with the vehicle traveling at less than 31 mph. During a descent, if engine braking is insufficient to control the vehicle speed, HDC (if selected) automatically operates the brakes to slow the vehicle and maintain a speed relative to the selected gear and the accelerator pedal position.

The ECM transmits throttle angle, engine torque, engine identification (V8 Thor) and transmission type to the SLABS control module to support the HDC system. This information is transmitted via a multiplexed PWM waveform.

The ECM has power stage diagnostics for the signal, with a fault being detected if any of the following conditions is satisfied: -

1. HDC link to the SLABS control module short circuit to battery positive, i.e. the driver voltage is greater than half the battery voltage when the driver is on.
2. HDC link to the SLABS control module short circuit to ground, i.e. the driver voltage is less than one third of the battery voltage when the driver is off.
3. HDC link to the SLABS control module open circuit, i.e. the driver voltage is greater than one third of the battery voltage but less than two thirds of the battery voltage when the driver is off.

Hill Decent Control Signal								
Component/ System	Fault Codes	Monitoring Strategy Description	Malfunction Criteria	Threshold value	Secondary Parameter	Enable Conditions	Time Required	MIL Illumination
Hill Decent Control Signal	P1665	circuit continuity - short to battery positive	voltage - drive on	voltage > 1/2 * Battery positive	engine speed battery voltage	> 80 rpm 7.5V < Battery positive < 17V	immediately/ continuous	two driving cycles
	P1664	circuit continuity – short to ground	voltage - drive off	voltage < 1/3 * Battery positive				
	P1663	circuit continuity – open circuit	voltage - drive off	1/3 * Battery positive < voltage < 2/3 * Battery positive				

If the above table does not include details of the following enabling conditions: - IAT, ECT, vehicle speed range, and time after engine start-up then the state of these parameters has no influence upon the execution of the monitor.



4.27 Engine Speed Signal

4.27.1 Description

The engine speed signal is sent by the ECM to the instrument pack, Body Control Module (BCM) and SLABS/ABS control module via a direct hardwired connection.

The ECM has power stage diagnostics for this signal with a fault being detected if any of the following conditions is satisfied: -

1. Engine speed signal driver short circuit to battery positive, i.e. the driver voltage is greater than half the battery voltage when the driver is on.
2. Engine speed signal driver short circuit to ground, i.e. the driver voltage is less than one third of the battery voltage when the driver is off.
3. Engine speed signal driver open circuit, i.e. the driver voltage is greater than one third of the battery voltage but less than two thirds of the battery voltage when the driver is off.

Engine Speed Signal								
Component/ System	Fault Codes	Monitoring Strategy Description	Malfunction Criteria	Threshold value	Secondary Parameter	Enable Conditions	Time Required	MIL Illumination
Engine Speed Signal	P0654	circuit continuity - short to battery positive	voltage - drive on	voltage > 1/2 * Battery positive	engine speed battery voltage	> 80 rpm 7.5V < Battery positive <17V	immediately/ continuous	no MIL illumination
	P0654	circuit continuity - short to ground	voltage - drive off	voltage < 1/3 * Battery positive				
	P0654	circuit continuity - open circuit	voltage - drive off	1/3 * Battery positive < voltage < 2/3 * Battery positive				

If the above table does not include details of the following enabling conditions: - IAT, ECT, vehicle speed range, and time after engine start-up then the state of these parameters has no influence upon the execution of the monitor.



4.28 Environmental-Box Cooling Fan – Range Rover 38A Only

4.28.1 Description

This function is required to control the Environmental-Box (E-Box) mounted cooling fan. This fan provides cabin air into the E-Box to provide a cool temperature environment for the ECM fitted in the under-bonnet mounted E-Box. The temperature is determined by an internally (to the ECM) mounted temperature sensor. The fan will be switched on at $40^{\circ}\text{C} \pm 15^{\circ}\text{C}$ and also tested for 2 seconds every engine start.

The ECM has power stage diagnostics for this signal with a fault being detected if any of the following conditions is satisfied: -

1. E-Box cooling fan driver short circuit to battery positive, i.e. the driver voltage is greater than half the battery voltage when the driver is on.
2. E-Box cooling fan driver short circuit to ground, i.e. the driver voltage is less than one third of the battery voltage when the driver is off.
3. E-box cooling fan driver open circuit, i.e. the driver voltage is greater than one third of the battery voltage but less than two thirds of the battery voltage when the driver is off.

Environmental-Box Cooling Fan – Range Rover 38A Only								
Component/ System	Fault Codes	Monitoring Strategy Description	Malfunction Criteria	Threshold value	Secondary Parameter	Enable Conditions	Time Required	MIL Illumination
E-Box Cooling Fan (Range Rover 38A only)	P1671	circuit continuity - short to battery positive	voltage - drive on	voltage > $1/2 * \text{Battery positive}$	engine speed	> 80 rpm	20 sec/	two driving
	P1670	circuit continuity – short to ground	voltage - drive off	voltage < $1/3 * \text{Battery positive}$	battery voltage	$7.5\text{V} < \text{Battery positive} < 17\text{V}$	continuous	cycles
	P1669	circuit continuity – open circuit	voltage - drive off	$1/3 * \text{Battery positive} < \text{voltage} < 2/3 * \text{Battery positive}$				

If the above table does not include details of the following enabling conditions: - IAT, ECT, vehicle speed range, and time after engine start-up then the state of these parameters has no influence upon the execution of the monitor.



4.29 Low Range Signal

4.29.1 Description

The transmission range switch information and calculated range data are transmitted from the automatic TCM via the CAN bus.

The ECM performs a rationality test between these signals, a fault is detected if one the following conditions are satisfied: -

1. The transmission range switch information indicates low range and the calculated range information indicates high.
2. The transmission range switch information indicates high range and the calculated range information indicates low.

Low Range Signal								
Component/ System	Fault Codes	Monitoring Strategy Description	Malfunction Criteria	Threshold value	Secondary Parameter	Enable Conditions	Time Required	MIL Illumination
Low Range Signal	P1700	plausibility check of the transfer gear signal	or	lever position = low range and gear information = high range lever position = high range & gear information = low range	throttle position vehicle speed engine load engine speed time after start	> 19.92% > 62.15 mph > 4.0 msec > 2000 rpm > 5.0 sec	5.0 sec/ continuous	no MIL illumination (diagnostics all default to enabled)

If the above table does not include details of the following enabling conditions: - IAT, ECT, vehicle speed range, and time after engine start-up then the state of these parameters has no influence upon the execution of the monitor.



4.30 Controller Area Network System

4.30.1 Description

The CAN is a high-speed serial interface for sharing dynamic signals between control modules. CAN communications are 'self checked' for errors, if an error is detected the message is ignored by the receiving control module. Due to the high rate of information exchange (500K baud) the system has a high degree of latency. This allows for a high amount of errors to be present without reducing the data transfer rate.

The CAN communication system is a differential bus using a twisted pair, which is normally very reliable. If either or both of the wires of the twisted pair CAN bus is open or short-circuited a CAN time out fault will occur and the automatic TCM defaults to third gear. In order to alert the driver the 'sport' and 'manual' warning lights in the instrument pack will flash alternatively.

An error is detected if the ECM receives no CAN messages for at least 0.8 seconds or the duration of the automatic TCM retard request is greater than 10 seconds.

CAN System								
Component/ System	Fault Codes	Monitoring Strategy Description	Malfunction Criteria	Threshold value	Secondary Parameter	Enable Conditions	Time Required	MIL Illumination
Transmission Interface	P1776	TCM ignition retard plausibility test	duration of retard request	> 10.0 sec	vehicle speed	> 24.86 mph	10.0 sec/ continuous	no MIL illumination (MIL request by TCM)
	P0600	CAN Time-out (bus check)	no CAN messages	> 0.80 sec			immediately/ continuous	two driving cycles

If the above table does not include details of the following enabling conditions: - IAT, ECT, vehicle speed range, and time after engine start-up then the state of these parameters has no influence upon the execution of the monitor.

4.31 Positive Crankcase Ventilation System Monitoring

4.31.1 Description

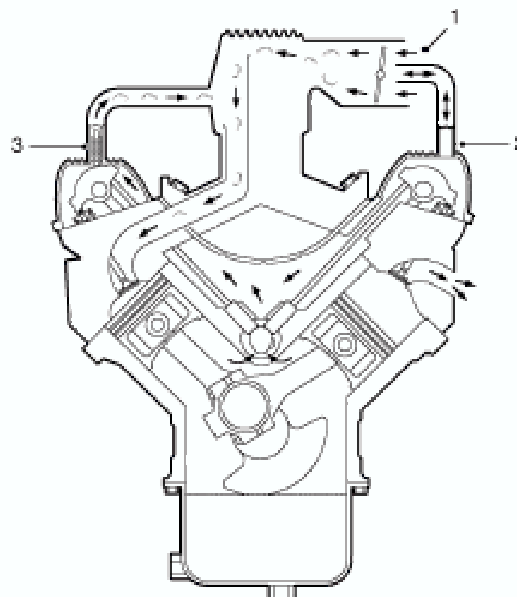

M17 0155

1. Intake air
2. Left hand rocker cover breather tube
3. Oil separator in right hand rocker breather tube

A spiral oil separator is located in the stub pipe to the ventilation hose on the right hand cylinder head rocker cover, where oil is separated and returned to the cylinder head. The rubber ventilation hose from the right hand rocker cover is routed to a port on the right hand side of the inlet manifold plenum chamber where the returned gases mix with the fresh intake air passing through the throttle butterfly valve. This pipe is primarily for part-load breathing and is connected to the engine via a restrictor that prevents an excessive vacuum building up in the crankcase at small throttle openings.

The stub pipe on the left hand rocker cover does not contain an oil separator or a restrictor and the ventilation hose is routed to the throttle body housing at the air inlet side of the butterfly valve. This pipe is for breathing at higher loads. Flow through this second pipe is negligible under normal driving conditions.

The ventilation hoses are attached to the stub pipes by metal band clamps.



Disconnection of the part-load breather is likely to result in a tendency of the engine to stall when returning to idle and the quantity of un-metered air, which flows into the intake manifold, will result in the detection of a fuel system fault by the OBD system.

For this reason, there are no separate monitors for compliance with the requirements of Positive Crankshaft Ventilation (PCV) monitoring.