

COOLING SYSTEM - V8

Description

General

The cooling system used on the V8 engine is a pressure relief by-pass type system which allows coolant to circulate around the cylinder block and the heater circuit when the thermostat is closed. With coolant not passing through the radiator, this promotes faster heater warm-up which in turn improves passenger comfort.

A coolant pump is located in a housing at the front of the engine and is driven by a drive belt. The pump is connected into the coolant passages cast in the cylinder block and pumps coolant from the radiator through the cylinder block.

A viscous fan is attached by means of a nut to the coolant pump pulley drive spindle. The fan draws air through the radiator to assist in cooling when the vehicle is stationary. The fan rotational speed is controlled relative to the running temperature of the engine by a thermostatic valve regulated by a bi-metallic coil.

The cooling system uses a 50/50 mix of anti-freeze and water.

Thermostat housing

A plastic thermostat housing is located behind the radiator. The housing has three connections which locate the radiator bottom hose, top hose and coolant pump feed hose. The housing contains a wax element and a spring loaded by-pass flow valve.

Thermostat - Main valve

The thermostat is used to maintain the coolant at the optimum temperature for efficient combustion and to aid engine warm-up. The thermostat is closed at temperatures below approximately 82°C (179°F). When the coolant temperature reaches approximately 82°C the thermostat starts to open and is fully open at approximately 96°C (204°F). In this condition the full flow of coolant is directed through the radiator.

The thermostat is exposed to 90% hot coolant from the engine on one side and 10% cold coolant returning from the radiator bottom hose on the other side.

Hot coolant from the engine passes from the by-pass pipe through four sensing holes in the flow valve into a tube surrounding 90% of the thermostat sensitive area. Cold coolant returning from the engine, cooled by the radiator, conducts through 10% of the sensitive area.

In cold ambient temperatures, the engine temperature is raised by approximately 10°C (50°F) to compensate for the heat loss of 10% exposure to the cold coolant returning from the bottom hose.

By-pass flow valve

The by-pass flow valve is held closed by a light spring. It operates to further aid heater warm-up. When the main valve is closed and the engine speed is at idle, the coolant pump does not produce sufficient flow and pressure to open the valve. In this condition the valve prevents coolant circulating through the by-pass circuit and forces the coolant through the heater matrix only. This provides a higher flow of coolant through the heater matrix to improve passenger comfort in cold conditions.

When the engine speed increases above idle the coolant pump produces a greater flow and pressure than the heater circuit can take. The pressure acts on the flow valve and overcomes the valve spring pressure, opening the valve and limiting the pressure in the heater circuit. The valve modulates to provide maximum coolant flow through the heater matrix and yet allowing excess coolant to flow into the by-pass circuit to provide the engine's cooling needs at higher engine rev/min.



Inlet manifold - Cooling connections

Coolant leaves the cylinder block via an outlet pipe attached to the front of the air intake manifold. The pipe is connected to the thermostat housing and the radiator by a branch hose off the radiator top hose.

Hot coolant from the engine is also directed from the inlet manifold via pipes and hoses into the heater matrix. Coolant is circulated through the heater matrix at all times when the engine is running.

A further tapping from the inlet manifold supplies coolant to the throttle housing via a hose. The coolant circulates through a plate attached to the bottom of the housing and is returned through a plastic bleed pipe to an expansion tank. The hot coolant heats the air intake of the throttle housing preventing ice from forming.

An Engine Coolant Temperature (ECT) sensor is fitted in the inlet manifold adjacent to the manifold outlet pipe. The sensor monitors coolant temperature emerging from the engine and sends signals to the ECM for engine management and temperature gauge operation.

 **ENGINE MANAGEMENT SYSTEM - V8, DESCRIPTION AND OPERATION, Description - engine management.**

Expansion tank

The expansion tank is located in the engine compartment. The tank is made from moulded plastic and attached to brackets on the right hand inner wing. A maximum coolant when cold level is moulded onto the tank.

Excess coolant created by heat expansion is returned to the expansion tank from the radiator bleed pipe at the top of the radiator. An outlet pipe is connected into the pump feed hose and replaces the coolant displaced by heat expansion into the system when the engine is cool.

The expansion tank is fitted with a sealed pressure cap. The cap contains a pressure relief valve which opens to allow excessive pressure and coolant to vent through the overflow pipe. The relief valve opens at a pressure of 1.4 bar (20 lbf.in²) and above.

Heater matrix

The heater matrix is fitted in the heater assembly inside the passenger compartment. Two pipes pass through the bulkhead into the engine compartment and provide coolant flow to and from the matrix. The pipes from the bulkhead are connected to the matrix, sealed with 'O' rings and clamped with circular rings.

The matrix is constructed from aluminium with two end tanks interconnected with tubes. Aluminium fins are located between the tubes and conduct heat away from the hot coolant flowing through the tubes. Air from the heater assembly is warmed as it passes through the matrix fins. The warm air is then distributed into the passenger compartment as required.

 **HEATING AND VENTILATION, DESCRIPTION AND OPERATION, Description.** When the engine is running, coolant from the engine is constantly circulated through the heater matrix.

Radiator

The 45 row radiator is located at the front of the vehicle. The cross-flow type radiator is manufactured from aluminium with moulded plastic end tanks interconnected with tubes. Aluminium fins are located between the tubes and conduct heat from the hot coolant flowing through the tubes, reducing the cooling temperature as it flows through the radiator. Air intake from the front of the vehicle when moving carries heat away from the fins. When the vehicle is stationary, the viscous fan draws air through the radiator fins to prevent the engine from overheating.

Two connections at the top of the radiator provide for the attachment of the top hose and bleed pipe. A connection at the bottom of the radiator allows for the attachment of the bottom hose to the thermostat housing.

Two smaller radiators are located in front of the cooling radiator. The lower radiator provides cooling of the gearbox oil and the upper radiator provides cooling for the engine oil.

 **MANUAL GEARBOX - R380, DESCRIPTION AND OPERATION, Description.**

 **AUTOMATIC GEARBOX - ZF4HP22 - 24, DESCRIPTION AND OPERATION, Description.**

 **ENGINE - V8, DESCRIPTION AND OPERATION, Description.**

Pipes and hoses

The coolant circuit comprises flexible hoses and metal formed pipes which direct coolant into and out of the engine, radiator and heater matrix. Plastic pipes are used for the bleed and overflow pipes to the expansion tank.

A bleed screw is installed in the radiator top hose and is used to bleed air during system filling. A drain plug is fitted to each cylinder bank in the cylinder block. These are used to drain the block of coolant.

COOLING SYSTEM - V8

Coolant pump

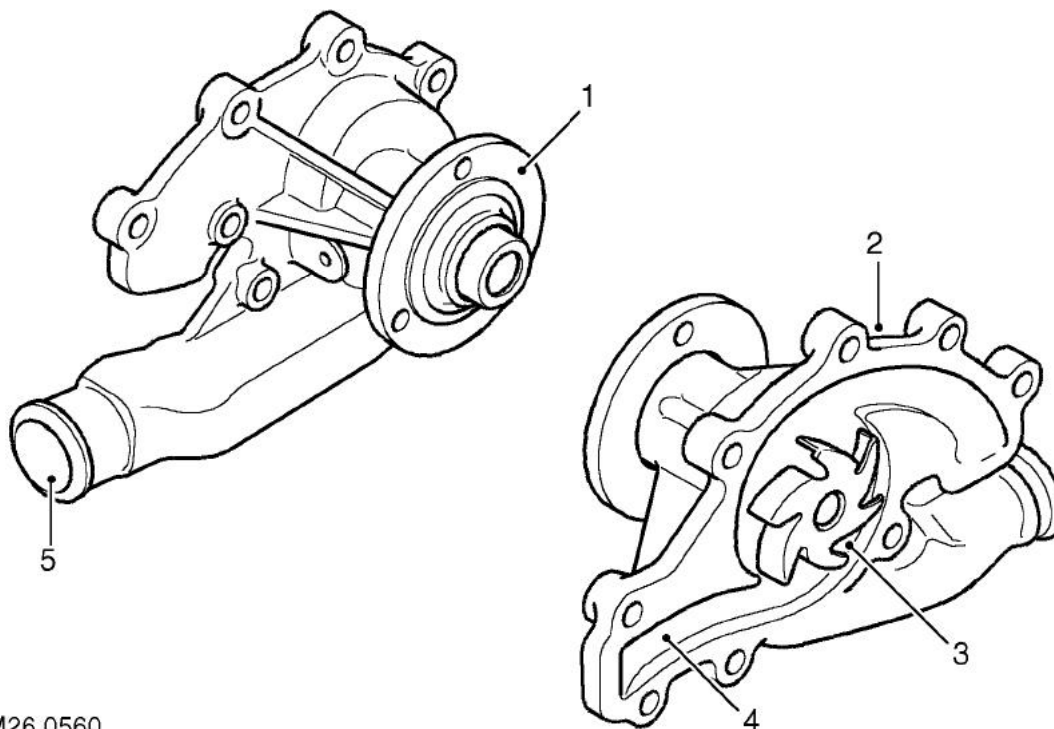

M26 0560

- 1 Pulley flange
- 2 Body
- 3 Impeller

- 4 Gallery
- 5 Inlet connection

The coolant pump is attached to the front of the cylinder block with nine bolts and sealed between the pump housing and the cylinder block with a gasket. The pump comprises a shaft which passes through an alloy housing. The outer end of the shaft has a flange which allows for the attachment of the pump drive pulley which is secured with three bolts. The drive pulley is driven by the grooved auxiliary drive belt and rotates at the same speed as the crankshaft. The inner end of the shaft is fitted with an impeller which draws coolant from the thermostat housing and circulates it through the galleries in the cylinder block and through the heater matrix.

The shaft is supported on bearings in the housing which are packed with grease and sealed for life. A seal is positioned in the housing to further protect the bearings from the ingress of coolant. The seal is manufactured from a synthetic material which will allow for expansion of the casing when hot coolant is present.

The cast alloy housing has a hose connection which provides the attachment for the coolant pump feed hose. The cast housing connects with galleries in the cylinder block and distributes coolant from the pump impeller into the galleries and water jackets.



Viscous fan

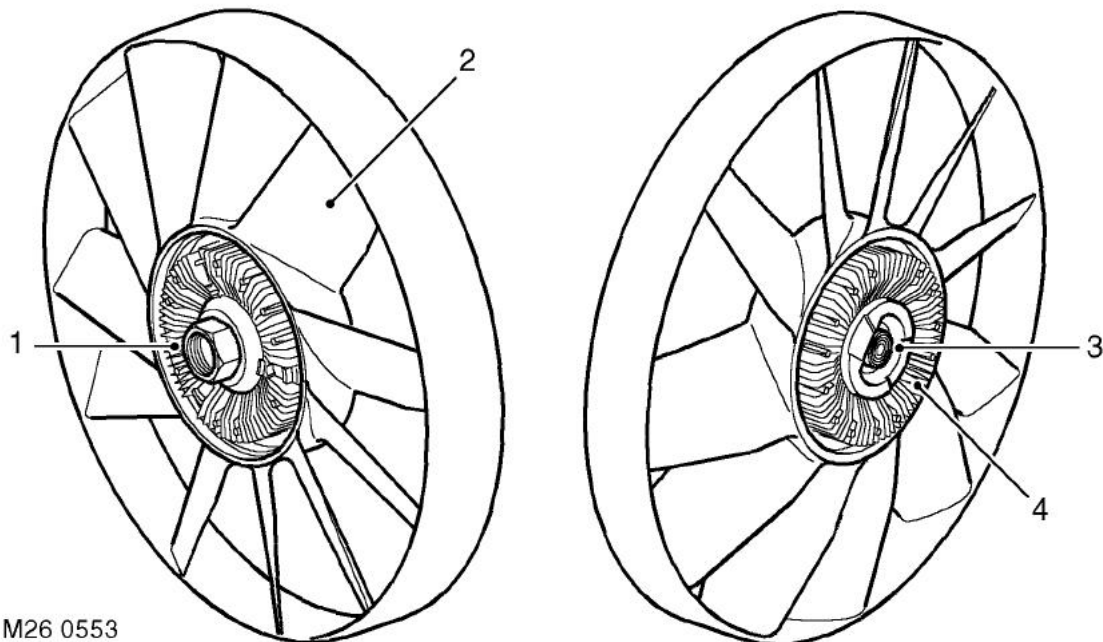

M26 0553

- 1 Coolant pump pulley drive attachment
- 2 Fan blades

- 3 Bi-metallic coil
- 4 Body

The viscous fan provides a means of controlling the speed of the fan relative to the operating temperature of the engine. The fan rotation draws air through the radiator, reducing engine coolant temperatures when the vehicle is stationary or moving slowly.

The viscous fan is attached to the coolant pump drive pulley and secured to the pulley by a nut. The nut is positively attached to a spindle which is supported on bearings in the fan body. The viscous drive comprises a circular drive plate attached to the spindle and driven from the coolant pump pulley and the coupling body. The drive plate and the body have interlocking annular grooves with a small clearance which provides the drive when silicone fluid enters the fluid chamber. A bi-metallic coil is fitted externally on the forward face of the body. The coil is connected to and operates a valve in the body. The valve operates on a valve plate with ports that connect the reservoir to the fluid chamber. The valve plate also has return ports which, when the valve is closed, scoop fluid from the fluid chamber and push it into the reservoir under centrifugal force.

Silicone fluid is retained in a reservoir at the front of the body. When the engine is off and the fan is stationary, the silicone fluid level stabilises between the reservoir and the fluid chamber. This will result in the fan operating when the engine is started, but the drive will be removed quickly after the fan starts rotating and the fan will 'freewheel'.

At low radiator temperatures, the fan operation is not required and the bi-metallic coil keeps the valve closed, separating the silicone fluid from the drive plate. This allows the fan to 'freewheel' reducing the load on the engine, improving fuel consumption and reducing noise generated by the rotation of the fan.

When the radiator temperature increases, the bi-metallic coil reacts and moves the valve, allowing the silicone fluid to flow into the fluid chamber. The resistance to shear of the silicone fluid creates drag on the drive plate and provides drive to the body and the fan blades.

COOLING SYSTEM - V8

Operation

Coolant flow - Engine warm up

Refer to illustration.

 **COOLING SYSTEM - V8, DESCRIPTION AND OPERATION, Cooling system coolant flow.**

During warm-up the coolant pump moves fluid through the cylinder block and it emerges from the inlet manifold outlet pipe. From the outlet pipe, the warm coolant flow is prevented from flowing through the radiator because the thermostat is closed. The coolant is directed into the heater circuit.

Some coolant from the by-pass pipe can pass through small sensing holes in the flow valve. The warm coolant enters a tube in the thermostat housing and surrounds 90% of the thermostat sensitive area. Cold coolant returning from the radiator bottom hose conducts through 10% of the thermostat sensitive area. In cold ambient temperatures the engine temperature can be raised by up to 10°C (50°F) to compensate for the heat loss of the 10% exposure to the cold coolant returning from the radiator bottom hose.

At engine idle speed, the by-pass valve is closed only allowing the small flow through the sensing holes. As the engine speed increases above idle, the greater flow and pressure from the pump overcomes the light spring and opens the by-pass flow valve. The flow valve opens to meet the engines cooling needs at higher engine speeds and prevents excess pressure in the system. With the thermostat closed, maximum flow is directed through the heater circuit.

The heater matrix acts as a heat exchanger reducing coolant temperature as it passes through the matrix. Coolant emerges from the matrix and flows into the coolant pump feed pipe and recirculated around the heater circuit. In this condition the cooling system is operating at maximum heater performance.

Coolant flow - Engine hot

As the coolant temperature increases the thermostat opens. This allows some coolant from the outlet housing to flow through the top hose and into the radiator to be cooled. The hot coolant flows from the left tank in the radiator, along the tubes to the right tank. The air flowing through the fins between the tubes cools the coolant as it passes through the radiator.

A controlled flow of the lower temperature coolant is drawn by the pump and blended with hot coolant from the by-pass and the heater return pipes in the pump feed pipe. The pump then passes this coolant into the cylinder block to cool the cylinders.