

HEATING AND VENTILATION

Blower assembly

80.20.12

Remove

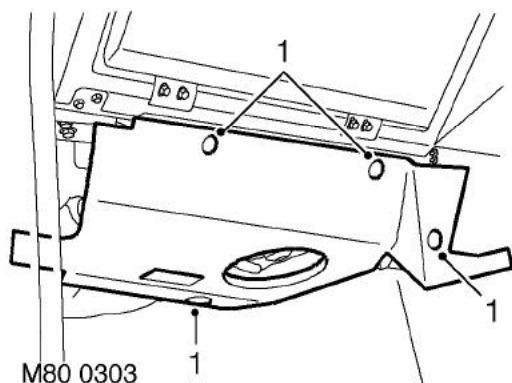

1. Remove 4 studs securing toe board and remove toe board.

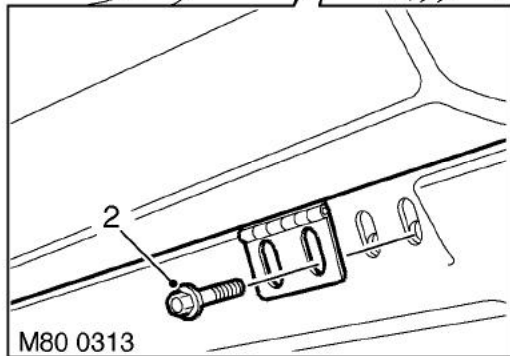
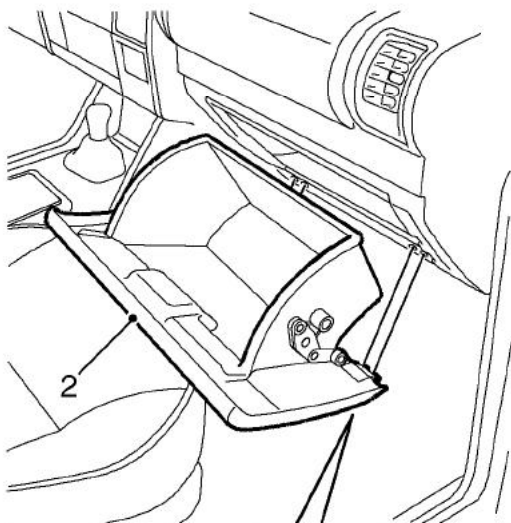

2. Remove 4 screws securing glove box, release catch and remove glove box.
3. Disconnect battery earth lead.

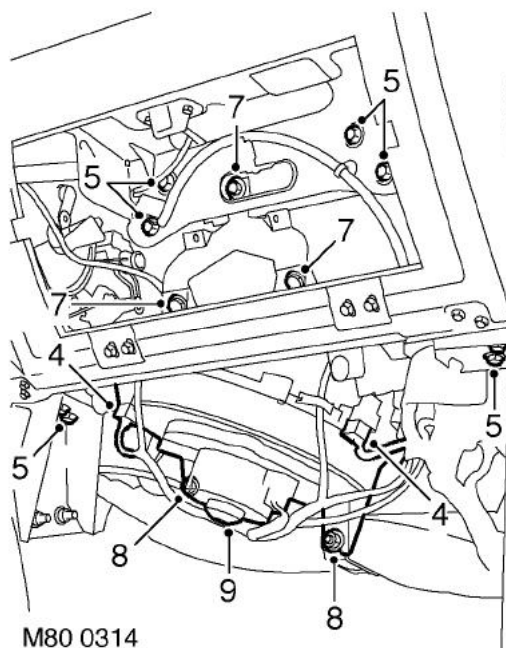

4. Disconnect multiplugs from blower motor.
5. Remove 8 bolts securing passenger side of fascia panel.
6. Carefully ease fascia away from bulkhead
7. Remove 3 bolts securing blower motor support bracket and remove bracket.
8. Remove 2 nuts securing motor assembly.
9. Release blower motor assembly from heater and manoeuvre from under fascia.

Refit

1. Position blower motor assembly under fascia and locate to heater casing.
2. Position support bracket, fit and tighten nuts and bolts.
3. Align fascia, fit bolt to support bracket and tighten to 26 Nm (19 lbf.ft).
4. Connect multiplugs to blower motor.
5. Connect battery earth lead.
6. Fit glove box, align hinges and tighten screws.
7. Position toe board and secure with studs.