

**Thermostat Monitoring sensor**

The thermostat monitoring sensor is located in the radiator, adjacent the bottom hose. The ECM compares the temperature measured by the thermostat monitoring sensor to the temperature measured by the ECT sensor. If the difference between the two readings is too great, the ECM determines the thermostat is stuck. In this case, the ECM registers a fault code in its memory.

The thermostat monitoring sensor works as a Negative Temperature Coefficient (NTC) sensor. As temperature rises, the resistance in the sensor decreases, as temperature decreases, the resistance in the sensor increases. With this information, the ECM is able to monitor the performance of the thermostat. The normal operating parameters of the thermostat monitoring sensor are as follows:

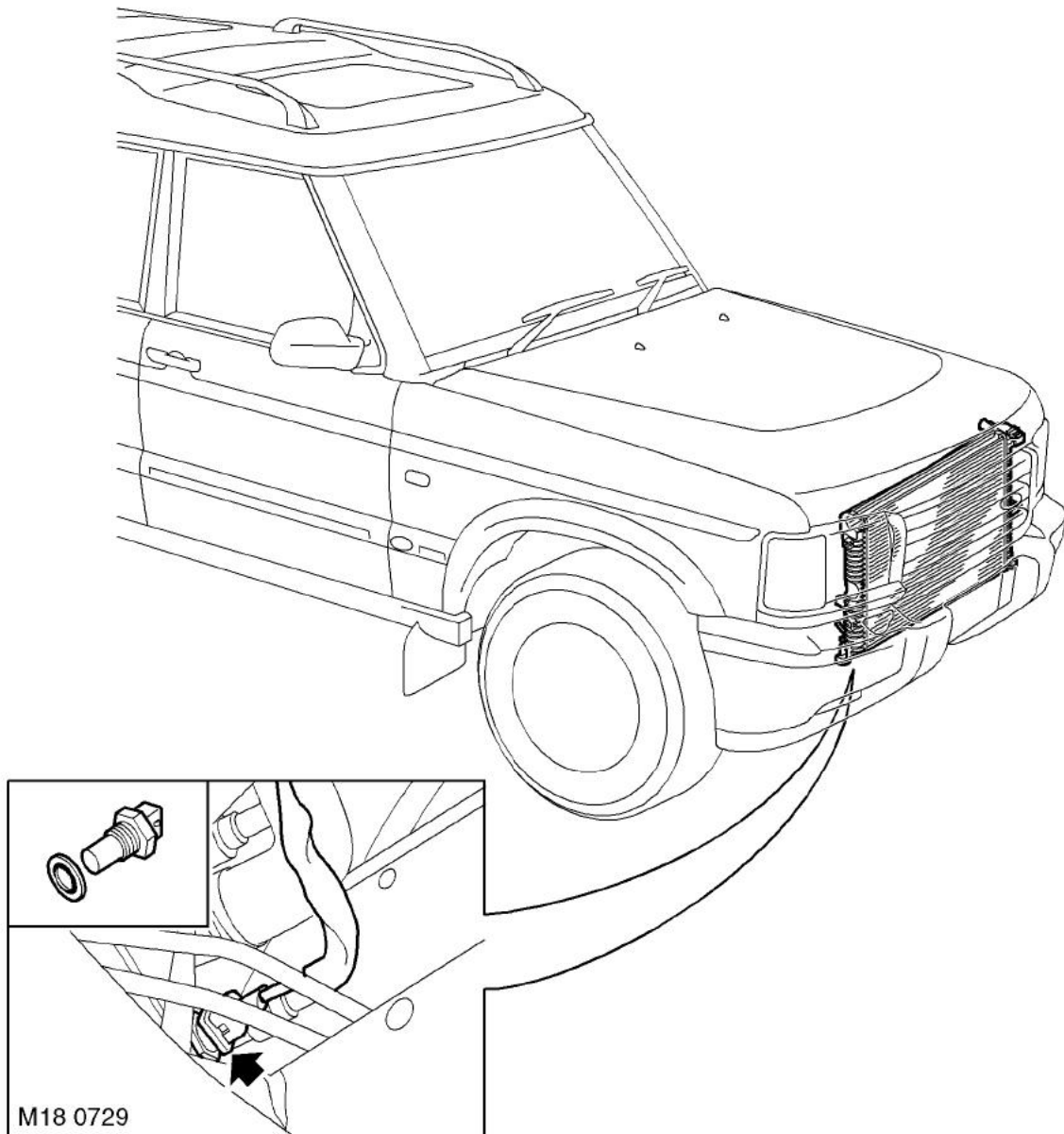
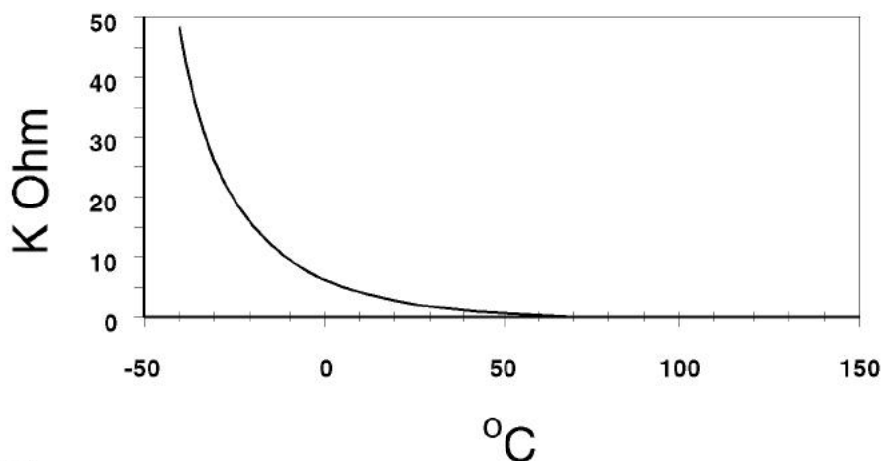

M18 0730

### ***Input/Output***

The ECM provides the thermostat monitoring sensor with a 5 volt reference via pin 21 of connector C0635 of the ECM, and an earth via pin 5 of connector C0635 of the ECM.

There are three types of thermostat monitoring sensor diagnostic checks:

- Sensor signal is above maximum threshold. For the ECM to register this as a fault, and illuminate the MIL, the temperature registered by the thermostat monitoring sensor must be above 140 °C (284 °F) for more than 1 second.
- Sensor signal is below minimum threshold. For the ECM to register this as a fault, and illuminate the MIL, the temperature registered by the thermostat monitoring sensor must be below -33 °C (-27 °F) for more than 1 second, while the inlet air temperature reading is greater than -32 °C (-25 °F).
- Signal difference between ECT sensor and thermostat monitoring sensor is below maximum threshold. For the ECM to register this as a fault, and illuminate the MIL, the following conditions must exist:
  - No maximum or minimum threshold signal faults exist.
  - No faults are recorded against the thermostat monitoring sensor or vehicle speed signal.
  - Engine not in idle speed control.
  - Fuel cut-off not active.
  - Engine speed is greater than 400 rpm.
  - Road speed is greater than 0 mph.
  - Integrated mass air flow from engine start to fuel cut-off is greater than set value (between 3 kg and 10 kg dependent upon engine coolant temperature at engine start).
  - Engine coolant temperature at engine start is between 9 °C and 39 °C (48 °F and 102 °F).
  - High range is selected.
  - Delay time before thermostat monitoring is enabled is between set limits (between 50 and 500 seconds dependent upon engine coolant temperature at engine start).
  - Engine coolant temperature is greater than 90 °C (194 °F).
  - The difference between the ECT sensor reading and the thermostat monitoring sensor reading is less than 39 °C (102 °F).



Should a malfunction occur, the following fault codes may be evident and can be retrieved by TestBook:

P code	J2012 description	Land Rover description
P1117	Radiator outlet temperature thermister low	Thermostat reading below -33 °C (-27 °F)
P1118	Radiator outlet temperature thermister high	Thermostat reading above 140 °C (284 °F)
P0126	Engine thermostat defective	Difference in radiator and engine coolant temperatures too small

**Mass Air Flow (MAF)/ Inlet Air Temperature (IAT) sensor (C0149)**

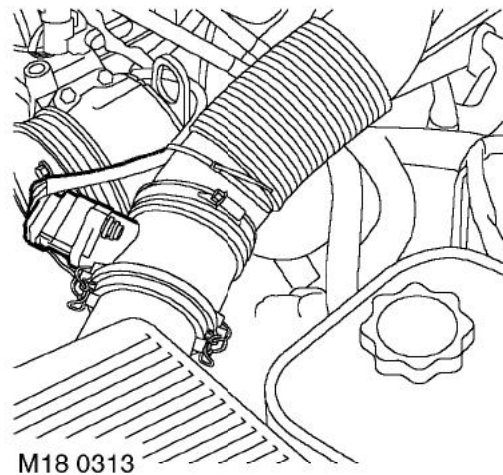

The MAF/ IAT sensors are combined into a single unit and located between the air filter housing and the inlet manifold. The ECM receives input signals from the MAF/ IAT sensor to calculate the mass of air flowing into the engine inlet manifold.

**Input/Output**

The MAF sensor has both electrical input and output. Input to the MAF sensor comes from two different sources. Battery voltage is supplied to the MAF sensor via fuse 2 of the engine compartment fuse box. The MAF sensor also utilises a 5 volt reference input via pin 7 of connector C0636 of the ECM. The MAF sensor output voltage is measured via pin 23 of connector C0636 of the ECM.

The IAT sensor has only electrical output. Output from the IAT sensor is measured at pin 34 of connector C0636 of the ECM, this is a variable voltage/ resistance measured by the sensor to provide air temperature information to the ECM.

The MAF/ IAT sensor share the same sensor earth. Sensor earth is via pin 9 of connector C0636 of the ECM.

The MAF/ IAT sensor and its connector has silver plated terminals for its low current signals to protect against corrosion. **DO NOT** apply 12V to the 5V supply, as this will destroy the internal circuitry. The MAF/IAT sensor should not be dropped or roughly handled and should be kept free from contamination.