





---

## Gasket - rear cover plate

---

➔ 41.20.30

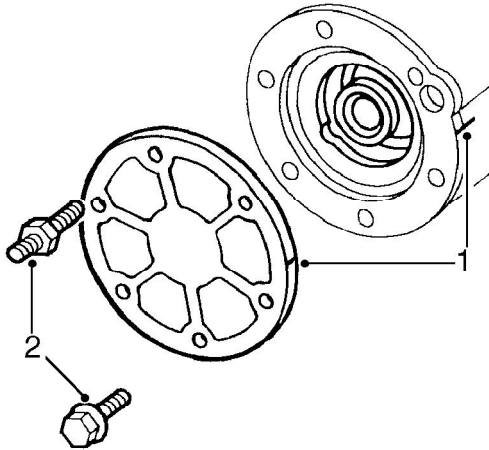
### Remove



M41 7476

1. Mark rear cover to bearing housing for assembly purposes.
2. Note fitted position of stud nut, remove stud nut and 5 bolts securing rear cover.
3. Carefully release rear cover from bearing housing.

### Refit

1. Clean rear cover, mating face on bearing housing and sealant from stud/bolt threads.
2. Apply sealant Part No. STC 4600 to rear cover mating face.
3. Align reference marks and position rear cover.
4. Apply sealant, Part No. STC 50552 to stud/bolt threads, fit rear cover plate stud nut and bolts and tighten to 25 Nm (18 lbf.ft).
5. Top-up transfer box oil.

 **MAINTENANCE, PROCEDURES, Transfer box.**