

ENGINE

OIL PUMP



NOTE: Overhaul procedures for the oil pump, oil pressure by-pass and relief valves are limited to carrying out dimensional checks. In the event of wear or damage being found, a replacement timing cover and oil pump assembly must be fitted.

Oil pump - remove

1. Remove timing cover.



CAUTION: Do not attempt to remove oil pump drive gear from inner rotor at this stage.

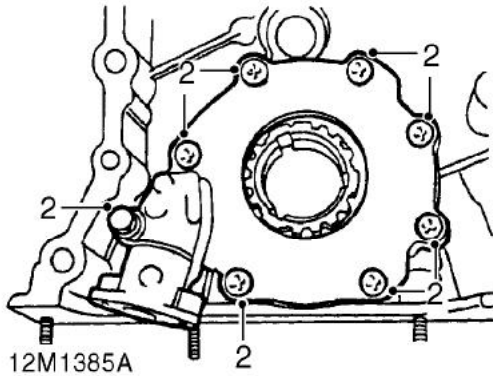

2. Remove 7 screws and bolt securing oil pump cover plate, remove plate.

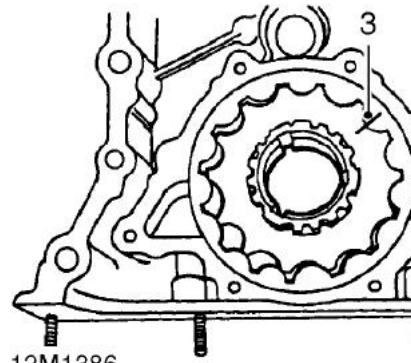

3. Make suitable alignment marks on inner and outer rotors, remove rotors and oil pump drive gear as an assembly.



Oil pressure by-pass valve - remove

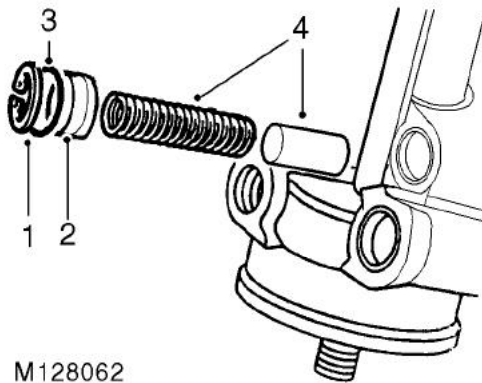

M128062

1. Remove circlip.
2. Remove by-pass valve plug.
3. Remove and discard 'O' ring from plug.
4. Remove by-pass valve spring and plunger.
5. Check plunger and bore of by-pass valve in oil pump body for scoring and corrosion.



NOTE: Light corrosion may be removed using grade 600 emery cloth soaked in oil.

Oil pressure relief valve - if fitted - remove

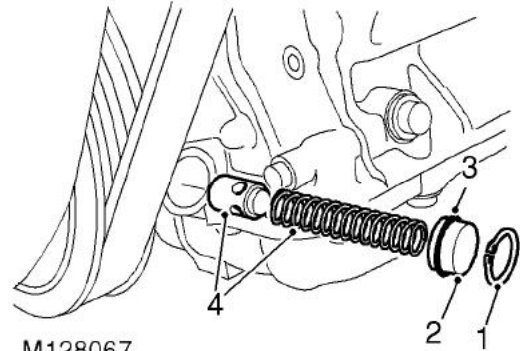

M128067

1. Remove circlip.
2. Remove relief valve plug.
3. Remove and discard 'O' ring from plug.
4. Remove relief valve spring and piston.
5. Check piston and bore of relief valve in oil pump body for scoring and corrosion.



NOTE: Light corrosion may be removed using grade 600 emery cloth soaked in oil.

ENGINE

Oil pump - inspection

1. Thoroughly clean oil pump drive gear, cover plate, rotors and housing. Remove all traces of sealant from threads of cover plate securing screws and bolt; ensure tapped holes in timing cover are clean and free from oil.
2. Check mating surfaces of cover plate, rotors and housing for scoring.
3. Assemble rotors and oil pump drive gear in housing ensuring that reference marks are aligned.

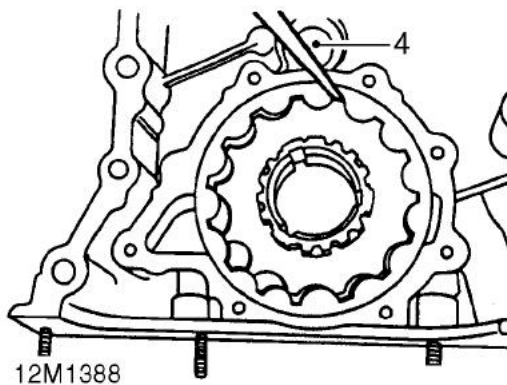

4. Using feeler gauges, check clearance between teeth of inner and outer rotors:
Maximum clearance = 0.25 mm (0.01 in)

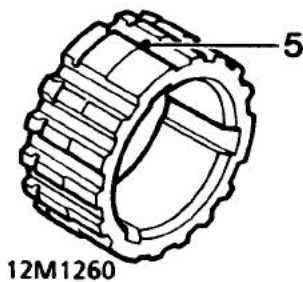

5. Remove oil pump drive gear, check depth of any wear steps on gear teeth:
Wear step maximum depth = 0.15 mm (0.006 in)

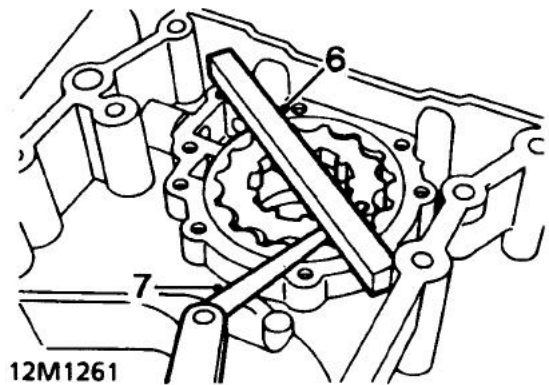

6. Place a straight edge across housing.
7. Using feeler gauges, check clearance between straight edge and rotors:
Maximum clearance = 0.1 mm (0.004 in).



Oil pressure by-pass valve - inspection

1. Clean by-pass valve components and plunger bore in timing cover.
2. Check plunger and bore for scoring and that plunger slides freely in bore with no perceptible side movement.
3. Check by-pass valve spring for damage and distortion; check spring free length:
Spring free length = 60.0 mm (2.4 in).

Oil pressure relief valve - if fitted - inspection

1. Clean relief valve components and piston bore in timing cover.
2. Check piston and bore for scoring and that piston slides freely in bore with no perceptible side movement.
3. Check relief valve spring for damage and distortion; check spring free length:
Spring free length = 60.0 mm (2.4 in).

ENGINE

Oil pump - refit

1. Lubricate rotors, oil pump drive gear, cover plate and housing with engine oil.
2. Assemble rotors and drive gear in housing ensuring that reference marks are aligned.
3. Position cover plate to housing.
4. Apply sealant, Part number STC 50552 to threads of cover plate screws and bolt.
5. Fit cover plate screws and bolt and tighten to:-
Screws - 4 Nm (3 lbf.ft)
Bolt - 8 Nm (6 lbf.ft)
6. Fit timing cover.

Oil pressure by-pass valve - refit

1. Lubricate new 'O' ring with engine oil and fit to by-pass valve plug.
2. Lubricate by-pass valve spring, plunger and plunger bore with engine oil.
3. Assemble plunger to by-pass valve spring, insert plunger and spring into bore.
4. Fit by-pass valve plug, depress plug and fit circlip.
5. Ensure circlip is fully seated in groove.



Oil pressure relief valve if fitted - refit

1. Lubricate new 'O' ring with engine oil and fit to relief valve plug.
2. Lubricate relief valve spring, piston and piston bore with engine oil.
3. Assemble piston to relief valve spring, insert piston and spring into piston bore.
4. Fit relief valve plug, depress plug and fit circlip.
5. Ensure circlip is fully seated in groove.

CAMSHAFT AND TAPPETS

Camshaft end-float - check

1. Remove rocker shaft assemblies.
2. Remove pushrods and store in their fitted order.
3. Remove timing chain and gears.

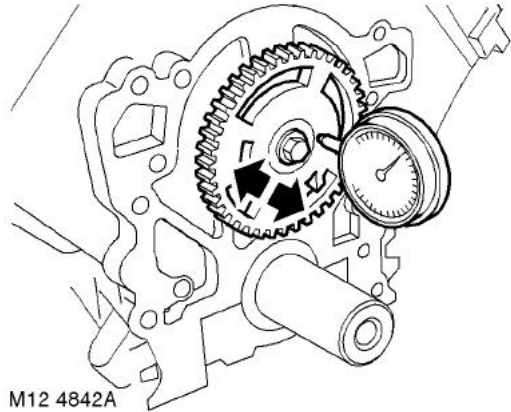

4. Temporarily fit camshaft gear and gear bolt.
5. Attach a suitable DTI to front of cylinder block with stylus of gauge contacting camshaft gear.
6. Push camshaft rearwards and zero gauge.
7. Using camshaft gear bolt, pull camshaft forwards and note end-float reading on gauge.
End-float = 0.05 to 0.25 mm (0.002 to 0.010 in)
8. If end-float is incorrect, fit a new thrust plate and re-check. If end-float is still incorrect, a new camshaft must be fitted.