



Refit

1. Clean park lock components.
2. Lubricate and fit new 'O' ring to output shaft.
3. Position park lock gear on the output shaft.
4. **Td5 models:** Fit the spacer.

CAUTION: Ensure that spacer is fitted on output shaft - Tdi Models only. If spacer is omitted, park gear and speed sensor may move out of position.

5. Position pivot pin, spring and ratchet.
6. Position parking pawl guide and guide plate, tighten Torx screw to 10 Nm (8 lbf.ft).
7. Clean extension housing and gearbox case.
8. Position new gasket to gearbox case.
9. Position extension housing and tighten bolts to 25 Nm (18 lbf.ft).
10. Fit transfer gearbox.
 - ☞ **TRANSFER BOX - LT230SE, REPAIRS, Transfer box - Diesel.**
 - ☞ **TRANSFER BOX - LT230SE, REPAIRS, Transfer box - V8.**
11. Fill automatic gearbox with oil.
 - ☞ **MAINTENANCE, PROCEDURES, Automatic gearbox.**

Gasket - oil sump

☞ **44.24.05**

Remove

1. Raise vehicle on ramp.
2. Drain automatic gearbox oil.
 - ☞ **MAINTENANCE, PROCEDURES, Automatic gearbox.**

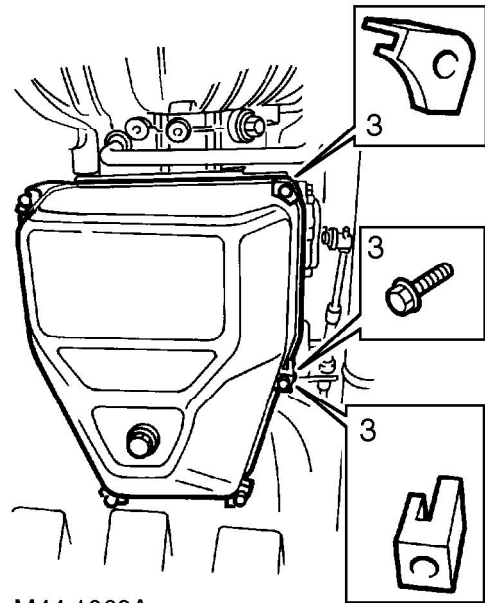

M44 1063A

3. Remove 6 bolts and spacers securing oil sump to gearbox, remove sump and discard gasket.

Refit

1. Clean oil sump and mating face.
2. Fit new gasket to oil sump, position sump to gearbox.
3. Position spacers and tighten bolts to 8 Nm (6 lbf. ft).
4. Fill automatic gearbox with oil.
 - ☞ **MAINTENANCE, PROCEDURES, Automatic gearbox.**
5. Lower vehicle.

Filter - oil

🔑 44.24.07

Remove

1. Remove oil sump gasket.
👉 **AUTOMATIC GEARBOX - ZF4HP22 - 24, REPAIRS, Gasket - oil sump.**

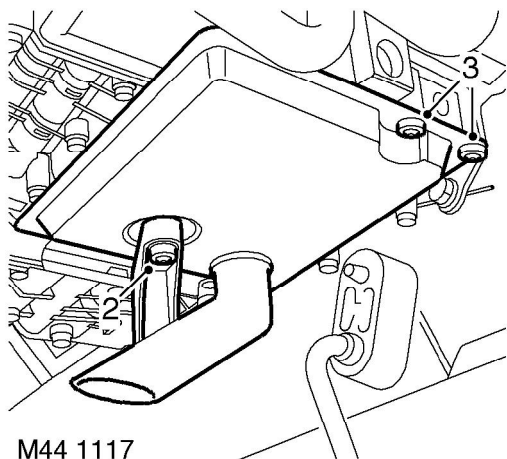

2. Remove Torx screw securing oil pick-up tube and remove tube.
3. Remove 2 Torx screws securing filter to valve body and discard 'O' rings.

Refit

1. Clean filter and pick-up tube using a lint free cloth.
2. Fit new 'O' rings to filter.
3. Position filter and tighten Torx screws to 8 Nm (6 lbf.ft).
4. Position oil pick-up tube and tighten Torx screw to 8 Nm (6 lbf.ft).
5. Fit oil sump gasket.
👉 **AUTOMATIC GEARBOX - ZF4HP22 - 24, REPAIRS, Gasket - oil sump.**