

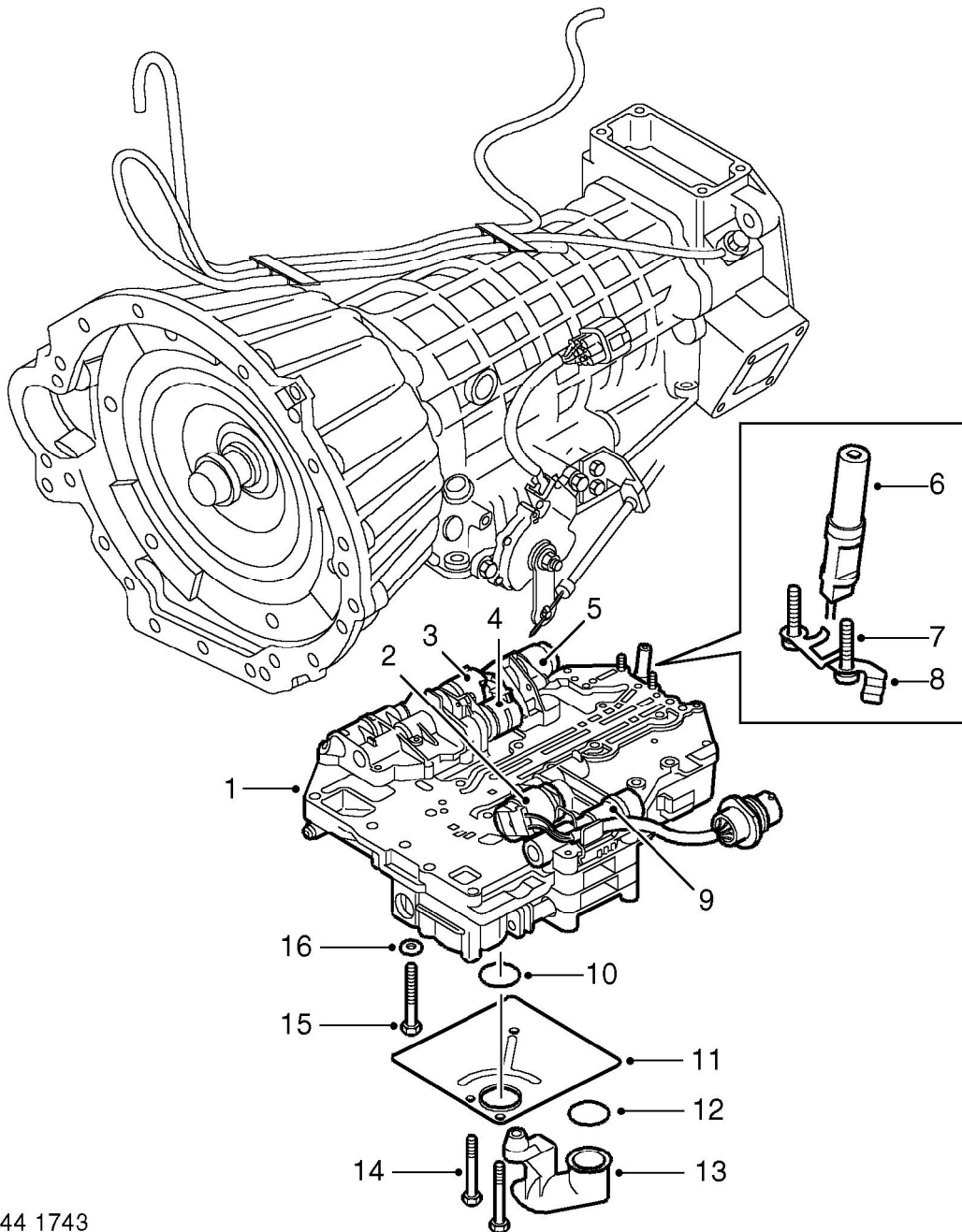

Valve block



M44 1743

- | | |
|---|-----------------|
| 1 Valve block | 9 Manual valve |
| 2 Pressure regulating solenoid valve (MV 4) | 10 'O' ring |
| 3 Shift control solenoid valve (MV 2) | 11 Filter |
| 4 Shift control solenoid valve (MV 1) | 12 'O' ring |
| 5 Lock-up solenoid valve (MV 3) | 13 Suction pipe |
| 6 Output shaft speed sensor | 14 Bolt |
| 7 Bolt | 15 Bolt |
| 8 Sensor retaining clip | 16 Washer |