

MAINTENANCE

Front and rear axle

WARNING: Avoid excessive skin contact with mineral oil. Mineral oils remove the natural fats from the skin, leading to dryness, irritation and dermatitis.

Replace oil

1. Place a suitable container beneath differential housing of axle to be drained.
2. Clean area around oil filler/level and drain plugs.

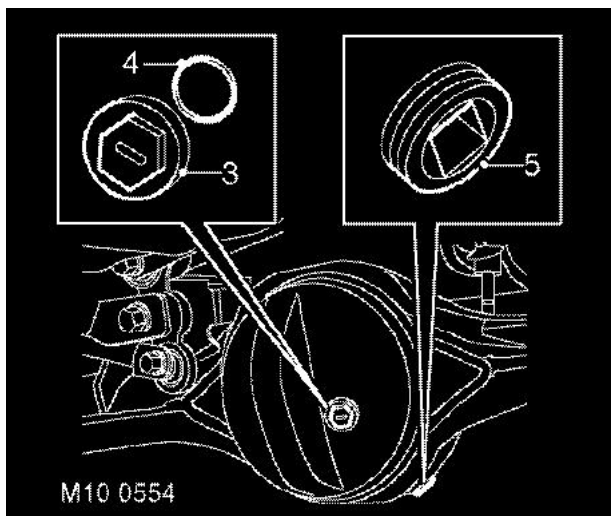

3. Remove oil filler/level plug.
4. Remove and discard 'O' ring from oil filler/level plug.
5. Remove oil drain plug, allow oil to drain.
6. Fit axle drain plug and tighten to 64 Nm (47 lbf.ft).
7. Fill differential housing with recommended oil to bottom of oil filler/level plug hole.
🔧 CAPACITIES, FLUIDS, LUBRICANTS AND SEALANTS, Lubrication.
8. Lubricate a new 'O' ring with recommended oil and fit to oil filler/level plug.
9. Fit axle filler/level plug and tighten to 10 Nm (7 lbf.ft).
10. Remove all traces of oil from differential housing.

Propeller shafts

Lubricate

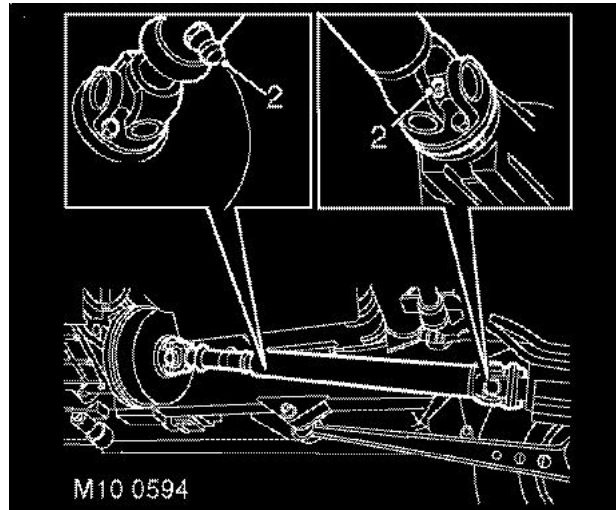

Rear shaft

1. Clean area around front universal joint grease nipple.
2. Apply recommended grease to the grease nipple.

🔧 CAPACITIES, FLUIDS, LUBRICANTS AND SEALANTS, Lubrication.

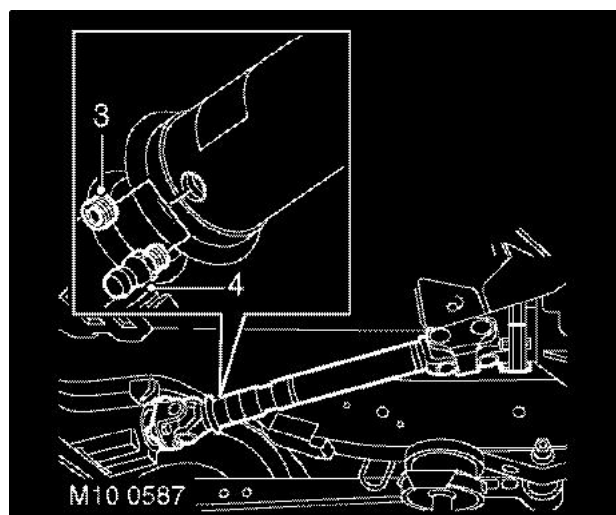

Front shaft

3. Remove blanking plug adjacent to sliding joint from propeller shaft.
4. Screw a 1/4in UNF grease nipple into blanking plug hole.