



ROCKER SHAFTS

Rocker shafts - remove

5. Mark each rocker shaft in relation to original cylinder head.



CAUTION: Incorrect fitment of rocker shafts will lead to an oil feed restriction.

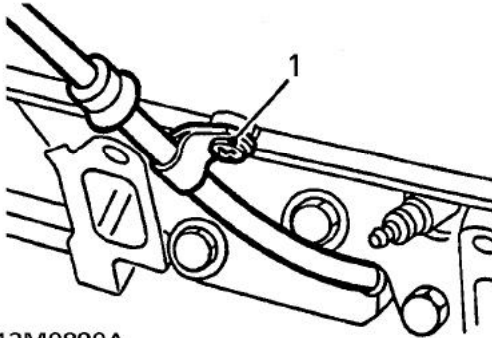

12M0890A

1. *LH rocker shaft only:* Remove screw securing dipstick tube to rocker cover.

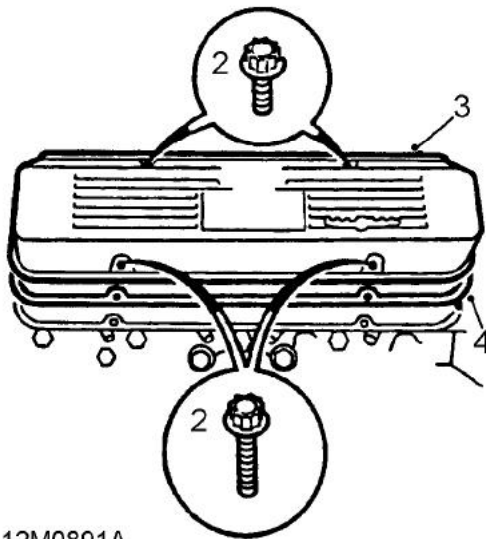

12M0891A

2. Noting fitted positions of 2 longer screws or multi-hex bolts, remove and discard screws/bolts securing rocker cover to cylinder head.
3. Remove rocker cover.
4. Remove and discard gasket from rocker cover.



CAUTION: Gaskets fitted to early engines were cork; these must be replaced with later type gaskets which incorporate compression limiters in the bolt holes.

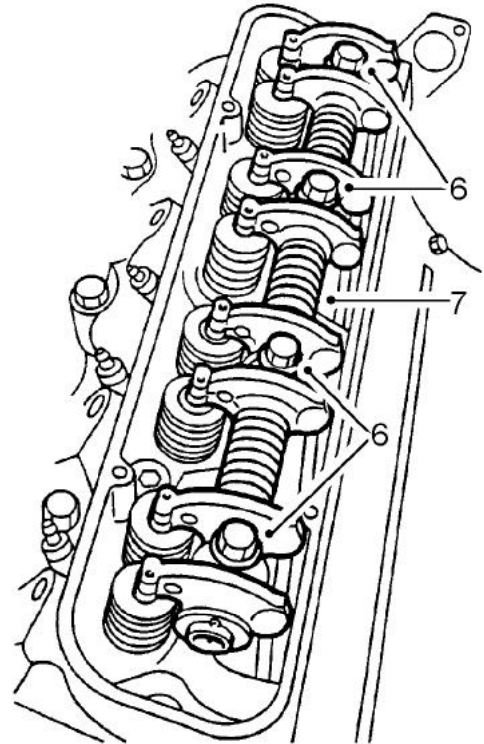

12M0892

6. Progressively slacken and remove 4 bolts securing rocker shaft assembly to cylinder head.
7. Remove rocker shaft assembly.
8. Remove pushrods and store in fitted order.

ENGINE

Rocker shafts - dismantling

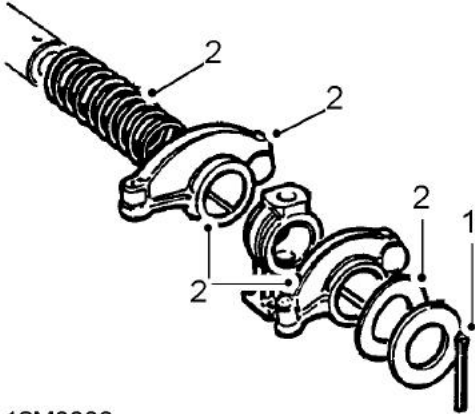

12M0886

1. Remove and discard split pin from one end of rocker shaft.
2. Remove plain washer, wave washer, rocker arms, brackets and springs.

Inspecting components

1. Thoroughly clean components.
2. Inspect each component for wear, in particular rocker arms and shafts. Discard weak or broken springs.
3. Inspect pushrod seats in rocker arms.
4. Check pushrods for straightness and inspect ball ends for damage, replace as necessary.



Rocker shafts - assembling

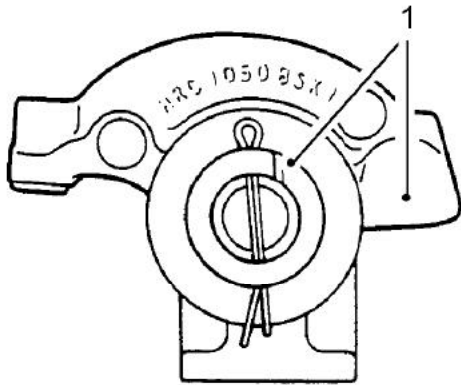

12M0887

1. Assemble rocker shafts with identification groove at one o'clock position with push rod end of rocker arm to the right.



CAUTION: Incorrect assembly of rocker shafts will lead to an oil feed restriction.

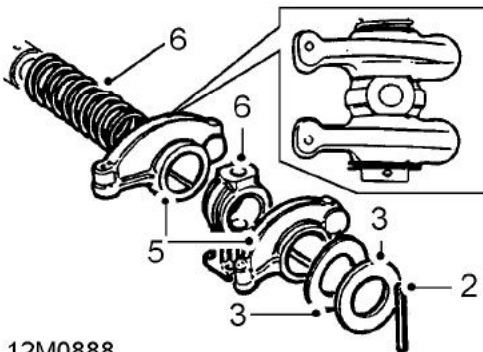

12M0888

2. Fit new split pin to one end of rocker shaft.
3. Fit plain washer and wave washer.
4. Lubricate rocker arm bushes with engine oil.
5. Fit rocker arms with offsets as illustrated.
6. Assemble rocker arms, brackets and springs to rocker shaft.
7. Compress springs, fit wave washer, plain washer and secure with new split pin.

Rocker shafts - refit

1. Lubricate pushrods with engine oil.
2. Fit pushrods in removed order.

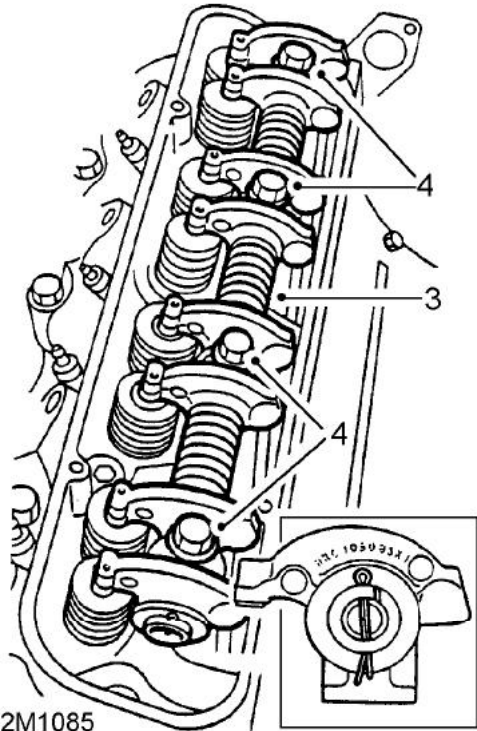

12M1085

3. Fit each rocker shaft assembly, ensuring identification groove is uppermost and towards front of engine on RH side and towards rear of engine on LH side.



CAUTION: Incorrect fitment of rocker shafts will lead to an oil feed restriction.

4. Fit bolts and starting at centre brackets, tighten to 38 Nm (28 lbf.ft).

5. Clean gasket surface in rocker cover and on cylinder head, ensure bolt holes are clean and dry.
6. Fit new gasket, dry to rocker cover.



CAUTION: Replace cork gasket(s) with modified gasket(s) which incorporate compression limiters in the bolt holes.

7. Fit rocker cover to cylinder head, fit new 'patched' multi-hex bolts and tighten in diagonal sequence to:
Stage 1 - 3 Nm (2.5 lbf.ft)
Stage 2 - 8 Nm (6 lbf.ft)



CAUTION: The 2 short bolts must be fitted on side of cover nearest centre of engine. Ensure that outer rim of gasket is correctly positioned around periphery of rocker cover.

8. *LH rocker shaft only:* Align dipstick tube to rocker cover, fit and tighten screw.

CYLINDER HEAD

Cylinder head - remove

1. Remove rocker shaft assembly.
2. Mark heads LH and RH for reassembly.

Engines fitted with secondary air injection (SAI)

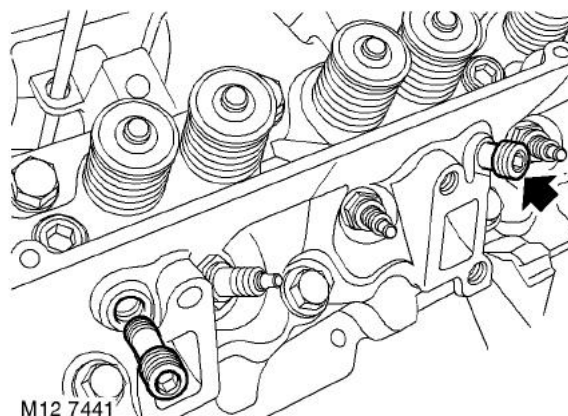

3. Using a suitable hexagonal drive bit, remove and discard 2 secondary air injection adapters from cylinder head.



NOTE: To release the adapter thread locking agent and prevent damage to the cylinder head, remove the adapters by loosening then tightening slightly. Repeat this procedure until the adapters are removed.



CAUTION: Do not use an air tool to remove adapters.