



Switch - starter inhibitor

🔑 44.15.19

Remove

1. **Diesel models:** Remove exhaust front pipe.
 **MANIFOLDS AND EXHAUST SYSTEMS - Td5, REPAIRS, Pipe - front.**
2. Move the selector lever to position 'P'.

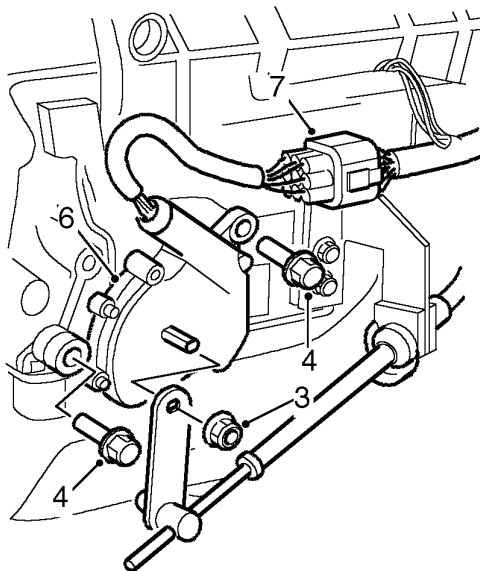

M44 1060A

3. Remove nut securing selector lever to gearbox selector shaft and release lever.
4. Remove 2 bolts securing inhibitor switch to gearbox.
5. Release multiplug from gearbox bracket.
6. Release inhibitor switch from selector shaft.
7. Disconnect switch multiplug and remove switch.

Refit

1. Ensure 'P' is selected by rotating selector shaft fully clockwise.
2. Engage 'N' by rotating selector shaft 2 detents anti-clockwise.
3. Position inhibitor switch to selector shaft, connect multiplug and secure multiplug to gearbox bracket.
4. Engage switch to selector shaft, and fit but do not tighten retaining bolts.

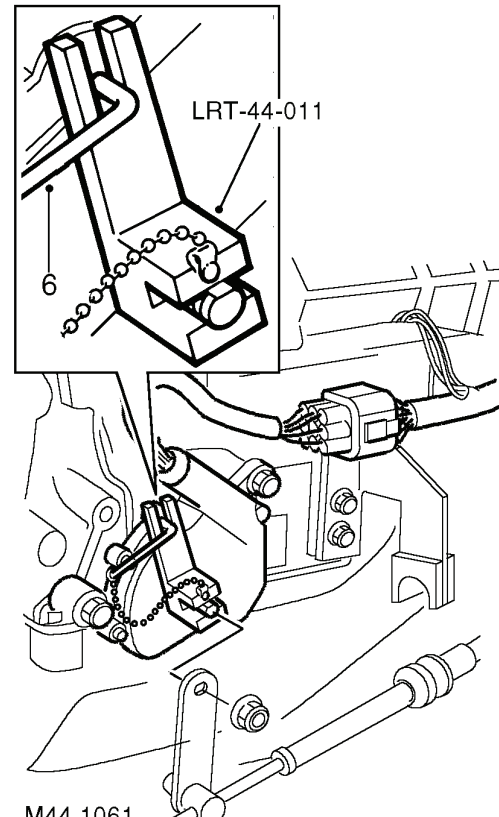

M44 1061

5. Fit tool **LRT-44-011** to selector shaft.
6. Insert setting pin into tool. Rotate switch until setting pin engages with hole in switch as shown and tighten bolts to 10 Nm (7 lbf.ft).
7. Remove setting tool **LRT-44-011**.
8. Position selector lever to selector shaft and tighten nut to 26 Nm (19 lbf.ft).
9. **Diesel models:** Fit exhaust front pipe.
 **MANIFOLDS AND EXHAUST SYSTEMS - Td5, REPAIRS, Pipe - front.**