

COLOUR CODES**DRAADKLEURCODES****CODICI COLORI DEI CAVI****CODES DES COULEURS DES FILS****CODIGOS DE COLORES DE LOS CABLES****KABELFARBCODES****CÓDIGOS DAS CORES DOS FIOS**

CODE	COLOUR	CODE	KLEUR	CODE	COULEUR	CODE	FARBE	CODICE	COLORE	CODIGO	COLOR	CÓDIGO	COR
B	BLACK	B	ZWART	B	NOIR	B	SCHWARZ	B	NERO	B	NEGRO	B	PRETO
G	GREEN	G	GROEN	G	VERT	G	GRÜN	G	VERDE	G	VERDE	G	VERDE
K	PINK	K	ROZE	K	ROSE	K	ROSA	K	ROSA	K	ROSA	K	ROSA
LG	LIGHT GREEN	LG	LICHTGROEN	LG	VERT CLAIR	LG	HELLGRÜN	LG	VERDE CHIARO	LG	VERDE CLARO	LG	VERDE CLARO
N	BROWN	N	BRUIN	N	BRUN	N	BRAUN	N	MARRONE	N	MARRON	N	CASTANHO
O	ORANGE	O	ORANJE	O	ORANGE	O	ORANGE	O	ARANCIONE	O	NARANJA	O	LARANJA
P	PURPLE	P	PAARS	P	VIOLET	P	LILA	P	PORPORA	P	PURPURA	P	ROXO
R	RED	R	ROOD	R	ROUGE	R	ROT	R	ROSSO	R	ROJO	R	VERMELHO
S	SLATE (grey)	S	LEIGRIJS	S	GRIS	S	GRAU	S	ARDESIA (grigio)	S	PIZARRO (gris)	S	CINZENTO
T	TRANSPARENT	T	TRANSPARANT	T	TRANSPARENT	T	TRANSPARENT	T	TRASPARENTE	T	TRANSPARENTE	T	TRANSPARENTE
U	BLUE	U	BLAUW	U	BLEU	U	BLAU	U	BLU	U	AZUL	U	AZUL
W	WHITE	W	WIT	W	BLANC	W	WEISS	W	BIANCO	W	BLANCO	W	BRANCO
Y	YELLOW	Y	GEEL	Y	JAUNE	Y	GELB	Y	GIALLO	Y	AMARILLO	Y	AMARELO

HOW TO USE THE CIRCUIT DIAGRAMS

All of the information in this publication is intended for use in conjunction with the Electrical Library, which can be found on RAVE.

The circuit diagrams are presented with Power and Earth distribution first, followed by individual circuits for each electrical system on the vehicle.

Power Distribution

The Power Distribution diagram shows the connections from the battery to the engine, passenger, and where applicable, rear fuse box. It also shows the internal circuitry of the fuse boxes.

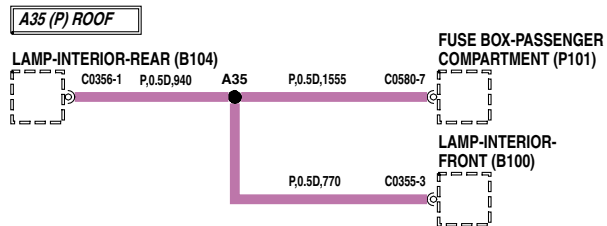

M86 5963

The fuse box details are followed by independent functionally specific circuits and then a splices and centre taps section outlining the way in which internal harness splices and centre taps distribute power in the harnesses. This information should be used during diagnosis of electrical faults to check for symptoms in associated circuits and narrow down the search area.

Earth Distribution

The earth distribution section comprises a number of Headers and Splices circuits. These are used in a similar manner to those in Power Distribution; to narrow the search area by checking for fault symptoms in associated circuits.

Splices and centre taps

Header and splice tables present the joint(s) and wiring up to the first component. Splices are identified by a number with an alphabetical prefix and the wire colour.

The splice information shown on individual system circuits is not complete. Always refer to the splices circuit for complete information on each splice.

Wire length (Power & Earth Distribution only)

The length of the wire is shown in millimetres. This can be used to locate internal harness splices; look for the shortest wire between the joint and connector. For example, it can be seen that C0580-7 is 1555mm from joint A35.

Connectors

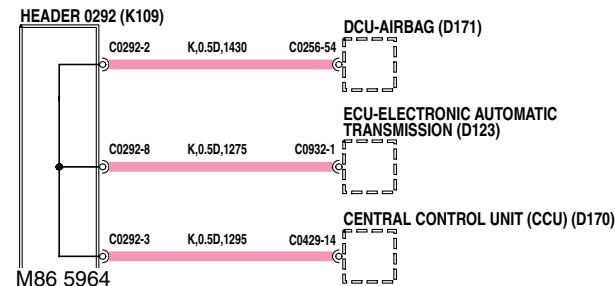

M86 5964

Header joints are identified by their corresponding connector number with a numbered suffix to indicate the pin-out detail of the wire, i.e. C0292-1 identifies connector 292, pin number 1. Wire insulation colour is identified in the normal way. Where wires have a predominant colour with a secondary colour tracer, the main colour is identified first, i.e. LGS - Light Green with a Slate tracer.

Line Types

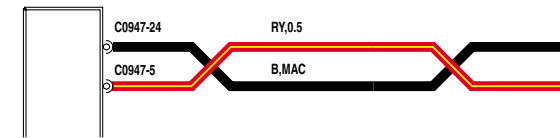

M86 5967

This denotes the wires are a twisted pair.

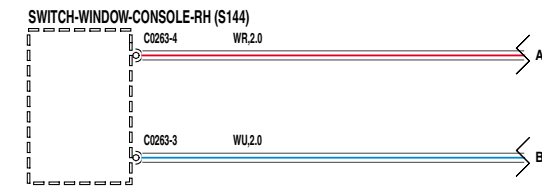

M86 5968

These page break symbols indicate the circuit continues on later pages.

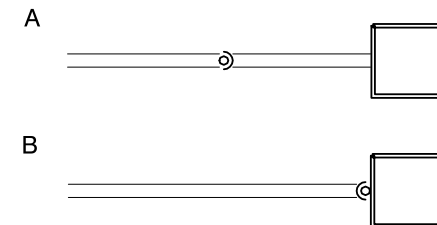

86M4230A

The cup and ball symbol indicates the male and female halves of connector.

A. Plug on lead (Flylead) wired directly to the component.

B. Connector plugs directly into component.

HOW TO USE THE CIRCUIT DIAGRAMS

Components

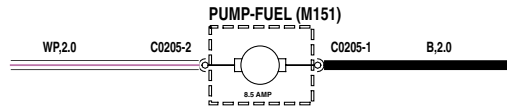

M86 5965

The name or description of the component is shown. A dotted outline indicates that the component is not shown in its entirety.

Earth points

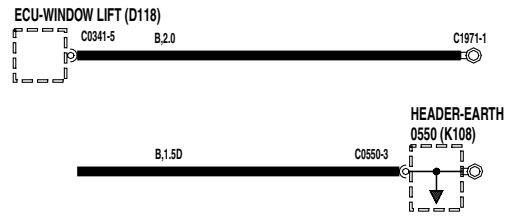

M86 5966

Earth points are identified with an eyelet symbol and a connector number, except where components are grounded through their fixings, when only the eyelet is shown.

Fuses and Diodes

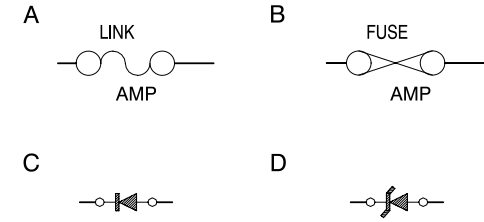

86M4234A

Fusible links (A) and current rated fuses (B) are identified as shown.

The direction of the arrow in a Diode symbol (C) indicates the direction of current flow. The Zener diode (D) - prevents current flow until a precise voltage is reached.

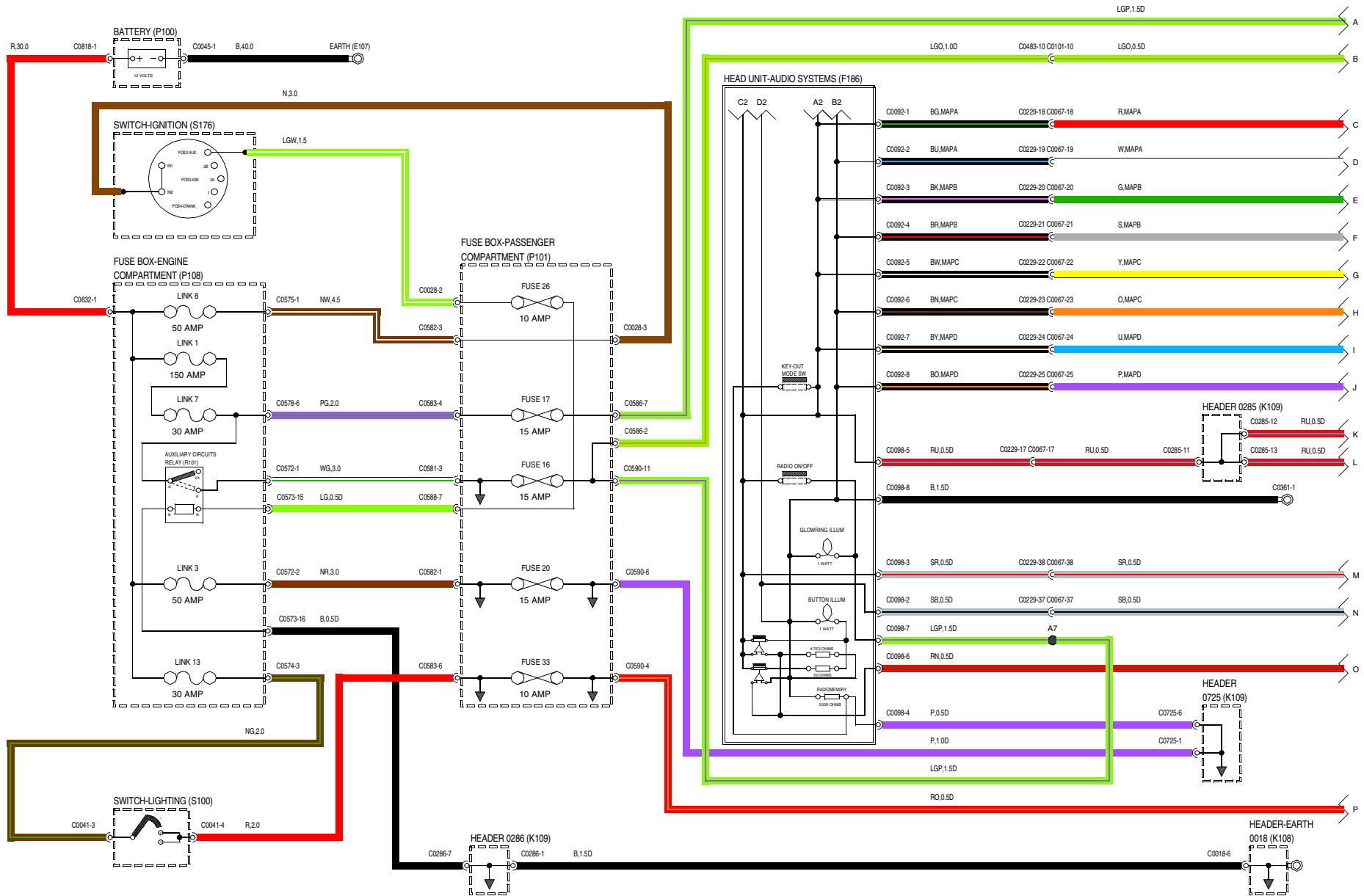

WRI08430-A-01

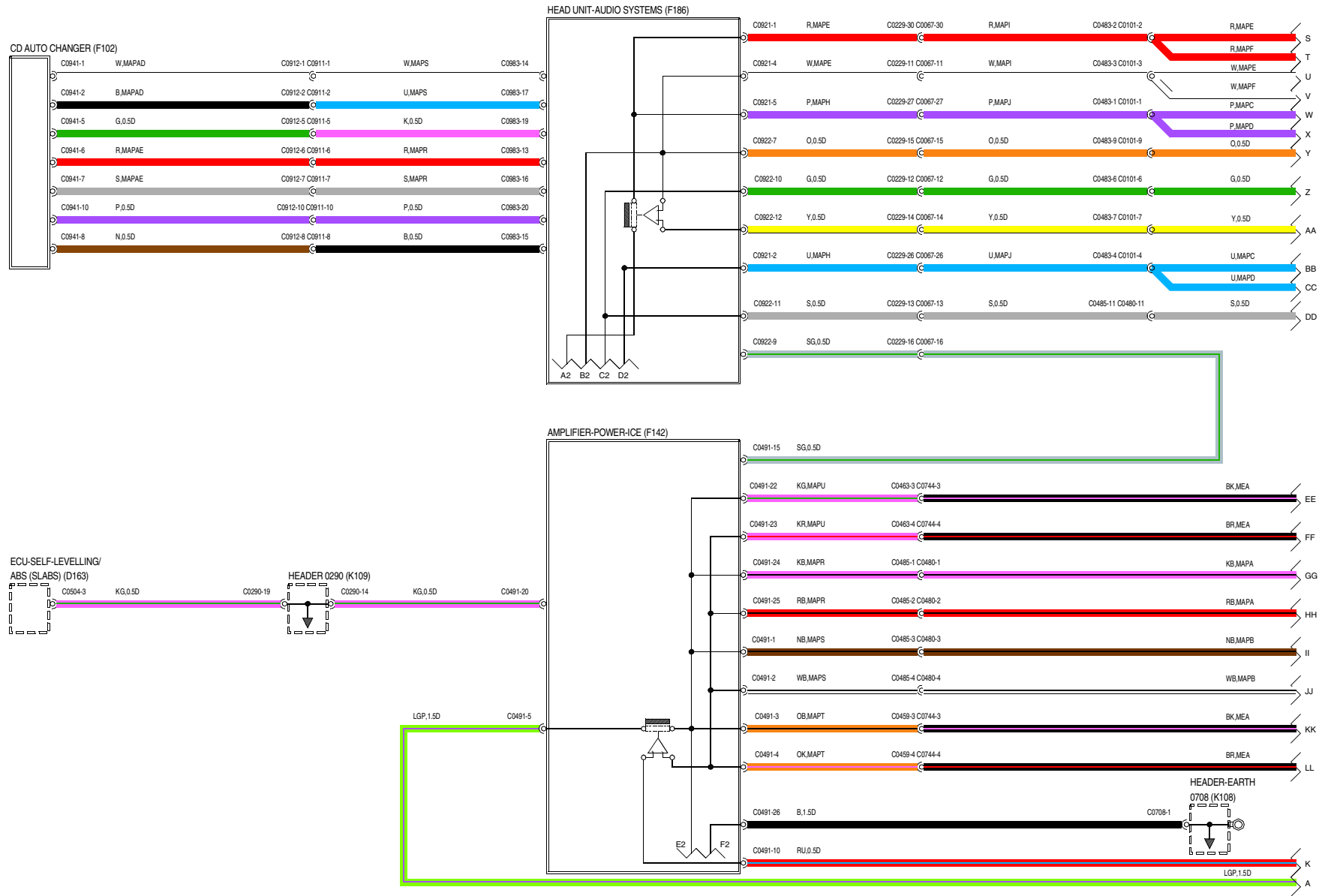

WVR108430-A-02

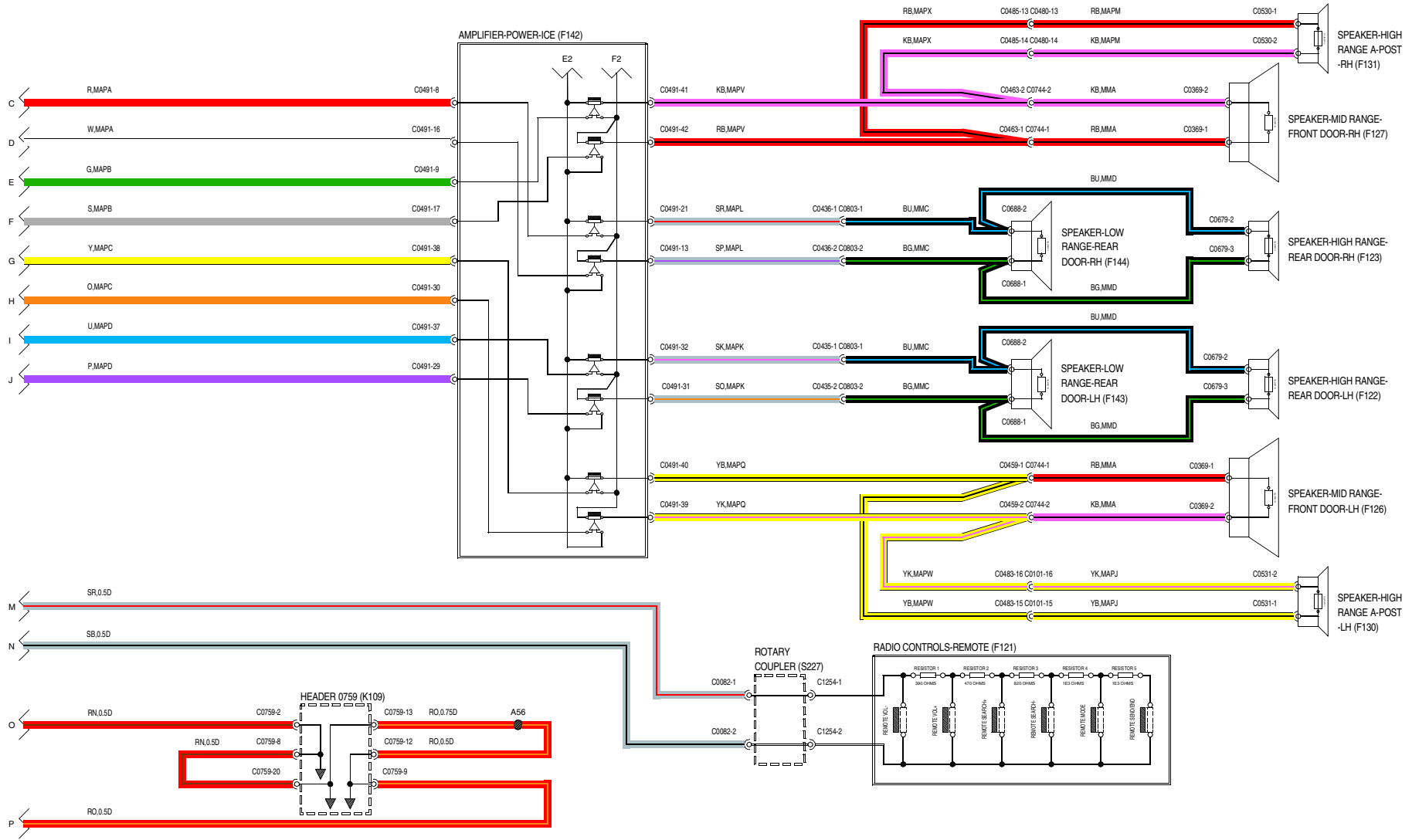

WVR108430-A-03

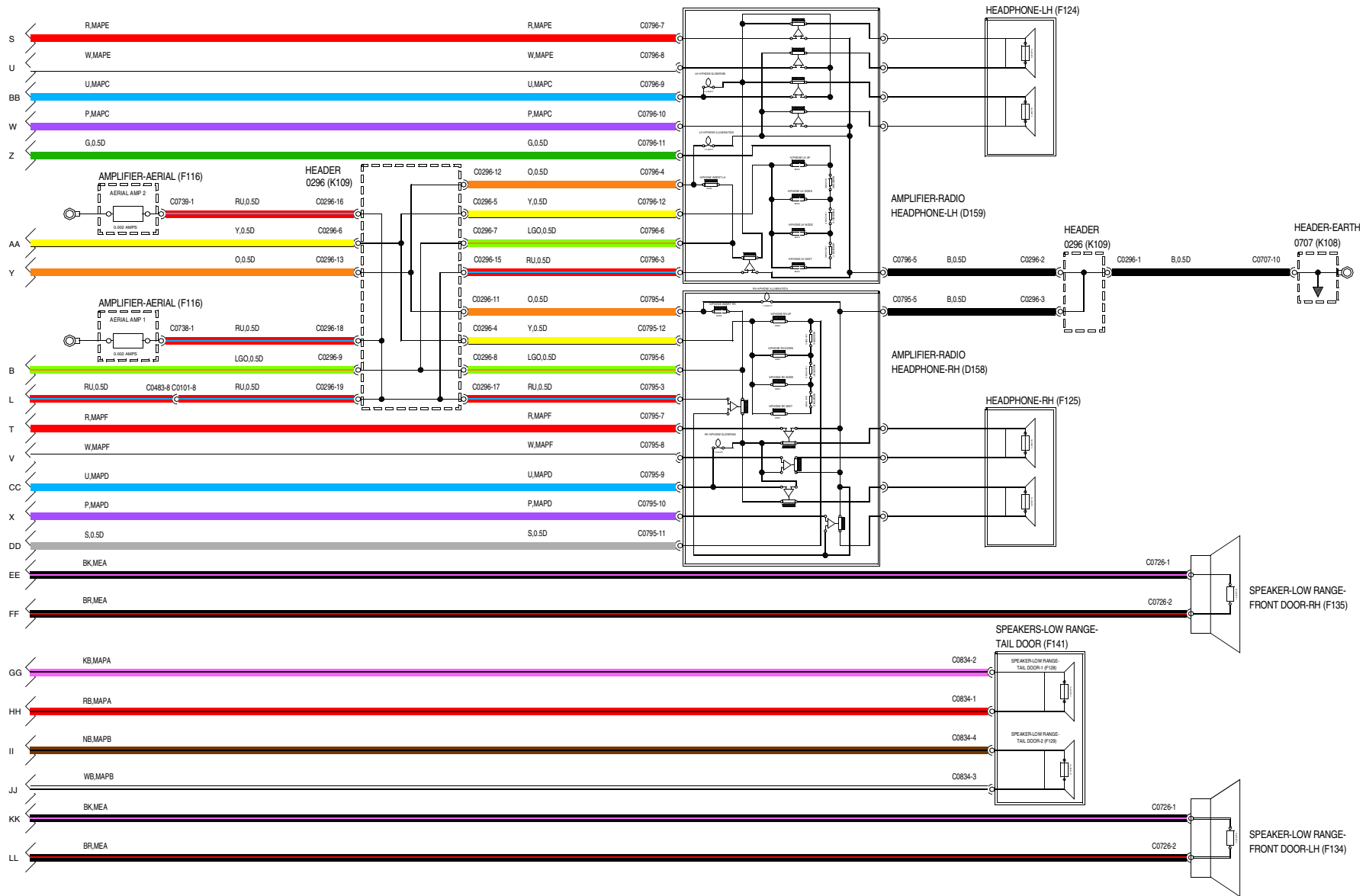

WWR108430-A-04