

AERIAL AMPLIFIER

Service repair no - 86.50.29

Remove

1. Remove parcel tray support panel. *See CHASSIS AND BODY, Repair.*
2. Disconnect 2 multiplugs from amplifier.

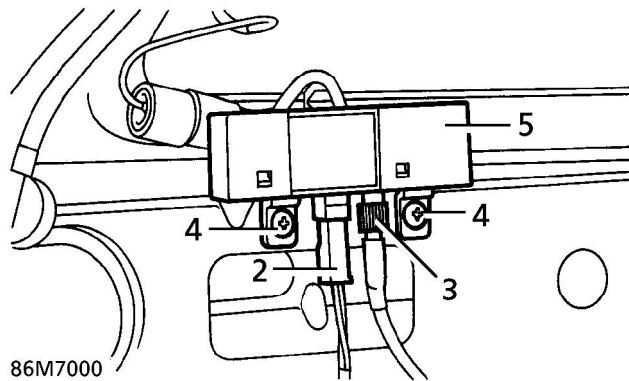

3. Release co-axial lead from amplifier.
4. Remove 2 screws securing aerial amplifier to body.
5. Remove aerial amplifier.

Refit

6. Reverse removal procedure.

AMPLIFIER - DIGITAL SOUND PROCESSING (DSP) - FROM 2000MY

Service repair no - 86.50.36

Remove

1. Remove LH parcel tray support trim. *See CHASSIS AND BODY, Repair.*

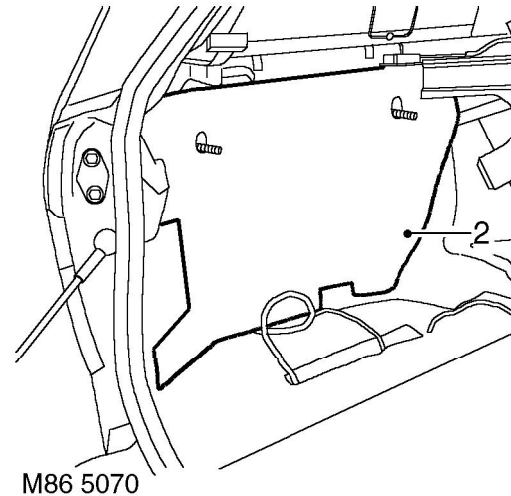

2. Remove sound insulation panel from body.

