

## CIRCUIT OPERATION

### Interface to transfer motor inside Transfer Box (X313)

The Transmission Gearbox Control Unit (Z256) has a seven wire interface to the Transfer Motor inside the Transfer Box (X313), consisting of the four motor position switches, the ground for the switches and the drives to move the motor one way or the other.

### Motor Position Switches—pins 17, 32, 33, 7

The Transmission Gearbox Control Unit (Z256) reads the position of the motor in the form of a binary Gray Code.

So the Transmission Gearbox Control Unit (Z256) can find out in which gear the Transfer Box (X313) is in and where the motor should move to, to engage the desired range. If the Transfer Box (X313) moves outside the normal modes (e.g. Left of High) then the Transmission Gearbox Control Unit (Z256) can move the motor back to the correct position.

### Motor Position Switch ground—pin 19

The switches on the transfer box motor are referenced to pin 19, i.e. if there is a problem with the harness to pin 19 then the Transmission Gearbox Control Unit (Z256) will not be able to assess where the transfer motor is and so will not move the motor.

### Motor drive Clockwise (pins 25, 26) and Counter Clockwise (pins 1, 2)

The Transmission Gearbox Control Unit (Z256) receives signals from the motor position switches, the drivers request, the vehicle speed and the transmission neutral signal and, when the parameters are correct, powers the motor from one mode to another via the motor drives. This is actually a single wire interface for each direction which is split down to two wires at the Transmission Gearbox Control Unit (Z256) to help pass the current through two pins rather than one. If there is a problem with either the motor drives or the harness, then the motor will not move and a range change will not be possible.

### Vehicle Speed Sensor—pins 13, 30

The Transmission Gearbox Control Unit (Z256) senses how fast the vehicle is travelling, compares this speed to the value stored in the memory and decides if a range change is allowed. Presently the shift speeds are set at 5 mph High to Low and Low to High on vehicles with an automatic transmission

and 15 mph Low to High on vehicles with a manual transmission.

### Interface to BeCM (Z238)

#### High, Low and Neutral Status Lamps —pins 35, 14, 36

The Transmission Gearbox Control Unit (Z256) informs the BeCM (Z238), which informs the Instrument Pack (Z142), about the range the vehicle is in via three status lamps.

When a range change is requested, the desired range will flash up on the display (i.e. "HIGH") and continue flashing until the range change is achieved. When complete, the range message will switch to constant and be displayed for a few seconds.

If a range change is requested and not all of the conditions are satisfied then the desired range message will flash and continue flashing until all of the parameters are satisfied or the request is removed.

If the transfer box neutral is selected then, after a five second safety delay, the Transfer Box (X313) moves to neutral and the display shows "NEUTRAL".

The High and Low status lamp signals also pass information to the H-Gate and the Auto Gear Box Control Unit (Z255).

### Interface to Engine Control Module (ECM) (Z132)

On North American Specification (NAS) vehicles, the inability of the Transfer Gear Box ECU (Z256) to move into the High range is flagged over the fault output line. A fault will also be flagged in the event of a speed sensor failure or incorrect transfer motor position information. The Malfunction Indicator Lamp (MIL) will illuminate if a fault is recorded on two successive journeys.

**Neutral Switch (X308) or Clutch Switch—pin 34**

A shift between ranges is possible when the transmission is in neutral. The Transmission Gearbox Control Unit (Z256) senses this via a Park/Neutral Switch (X308) on automatic transmission vehicles and via either a clutch switch or a lever neutral switch on manual transmission vehicles. This signal is passed via the BeCM (Z238).

**Interface to “H–Gate”—pin 35, 15 (automatic transmission only)**

The H–Gate gets the range information via a High and Low status signal from the output of the Transmission Gearbox Control Unit (Z256); e.g. when the vehicle is in High then the High side of the “H” is illuminated. When a range change to Low is requested, the Low side of the “H” starts to flash whilst the High side stays constant. When Low range is obtained then the flashing light on the Low side changes to constant and the High side light goes off.

If a range change is requested and not all of the conditions are satisfied, then the current range will stay illuminated and the desired range will flash and continue flashing until all of the parameters are satisfied or the request is removed.

If the gear lever is placed in the neutral position for the gearbox and the transfer box then, after a five second safety delay, the transfer box moves to neutral and the lights on both side of the “H” are extinguished.

**Interface to Auto Gear Box Control Unit (Z255) – pin 35**

The High/Low signal to the Auto Gear Box Control Unit (Z255) comes from the High range status lamp. If the Auto Gear Box Control Unit (Z255) does not receive the range information, then an incorrect gear change mode could be selected, i.e. Manual rather than Sport in High range and vice versa in Low range. Also, the shift strategy is different between the Economy modes of High and Low and so poor shift quality could result.

**Automatic Selector Park Interlock**

When the gear selector lever is in the park position, the shift interlock solenoid is deenergized and prevents the selector from being moved to another gear. To free the selector, the Ignition Switch (X134) must be in position II and the brake pedal must be depressed.

Current is then supplied to the solenoid through the PR wire via fuse 13. The solenoid is grounded using the B wire to the console ground E621.

The solenoid is now energised, freeing the selector. The solenoid is energised continuously whilst the selector lever is in any position other than park and the Ignition Switch (X134) is in position II.

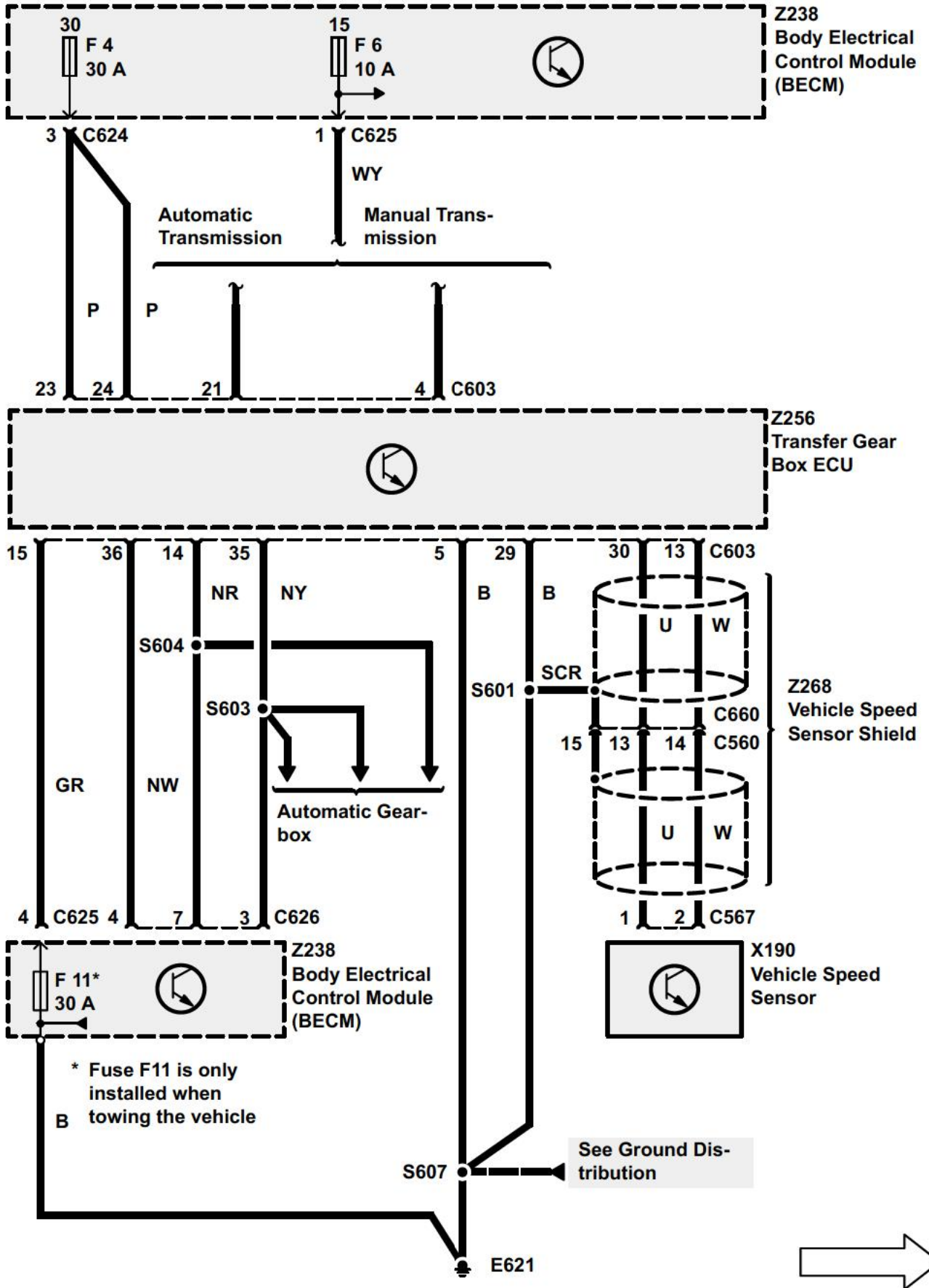

\* Fuse F11 is only installed when towing the vehicle

See Ground Distribution

← Manual Transmission

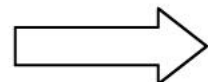
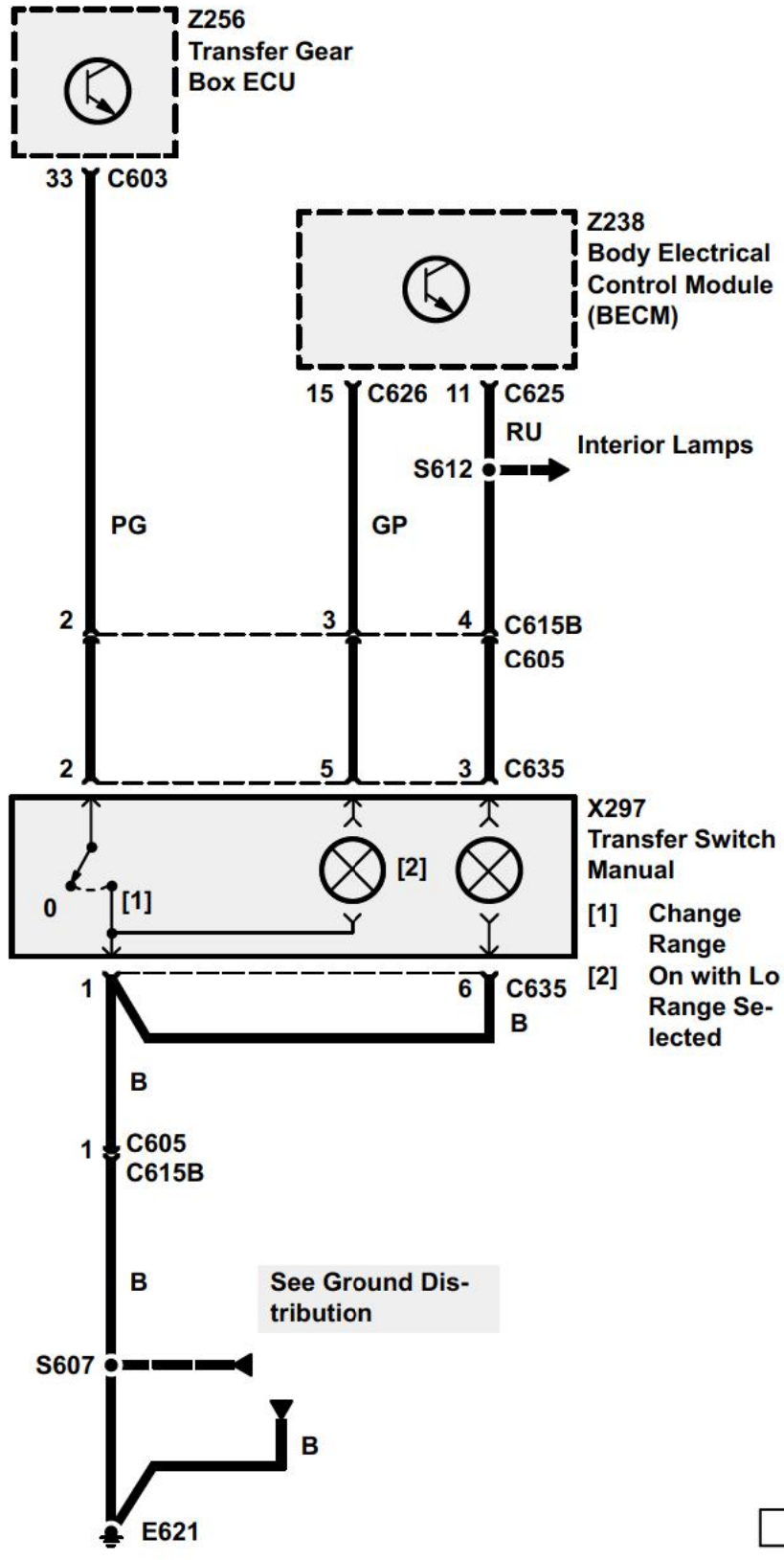

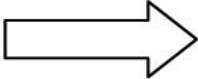
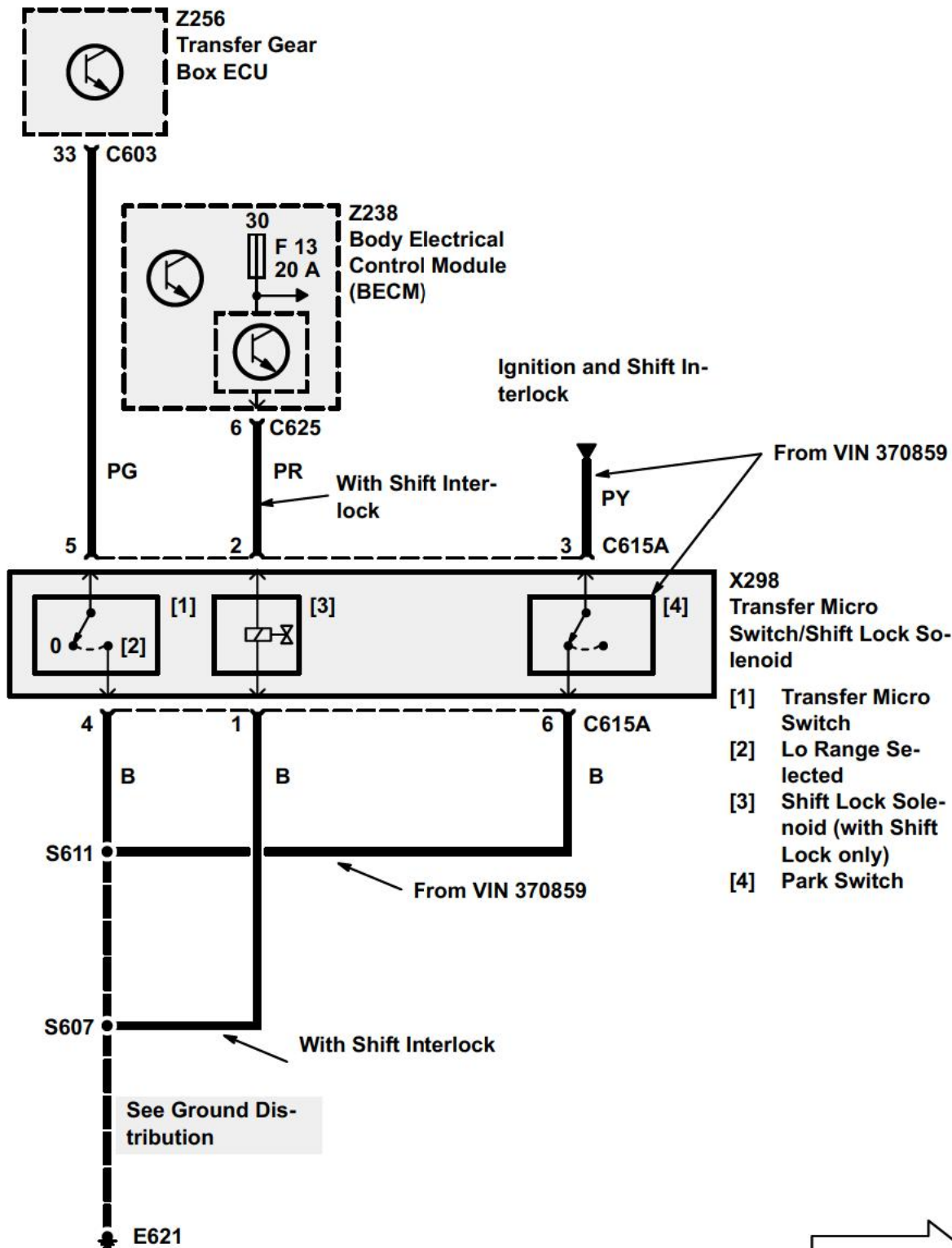
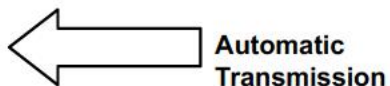

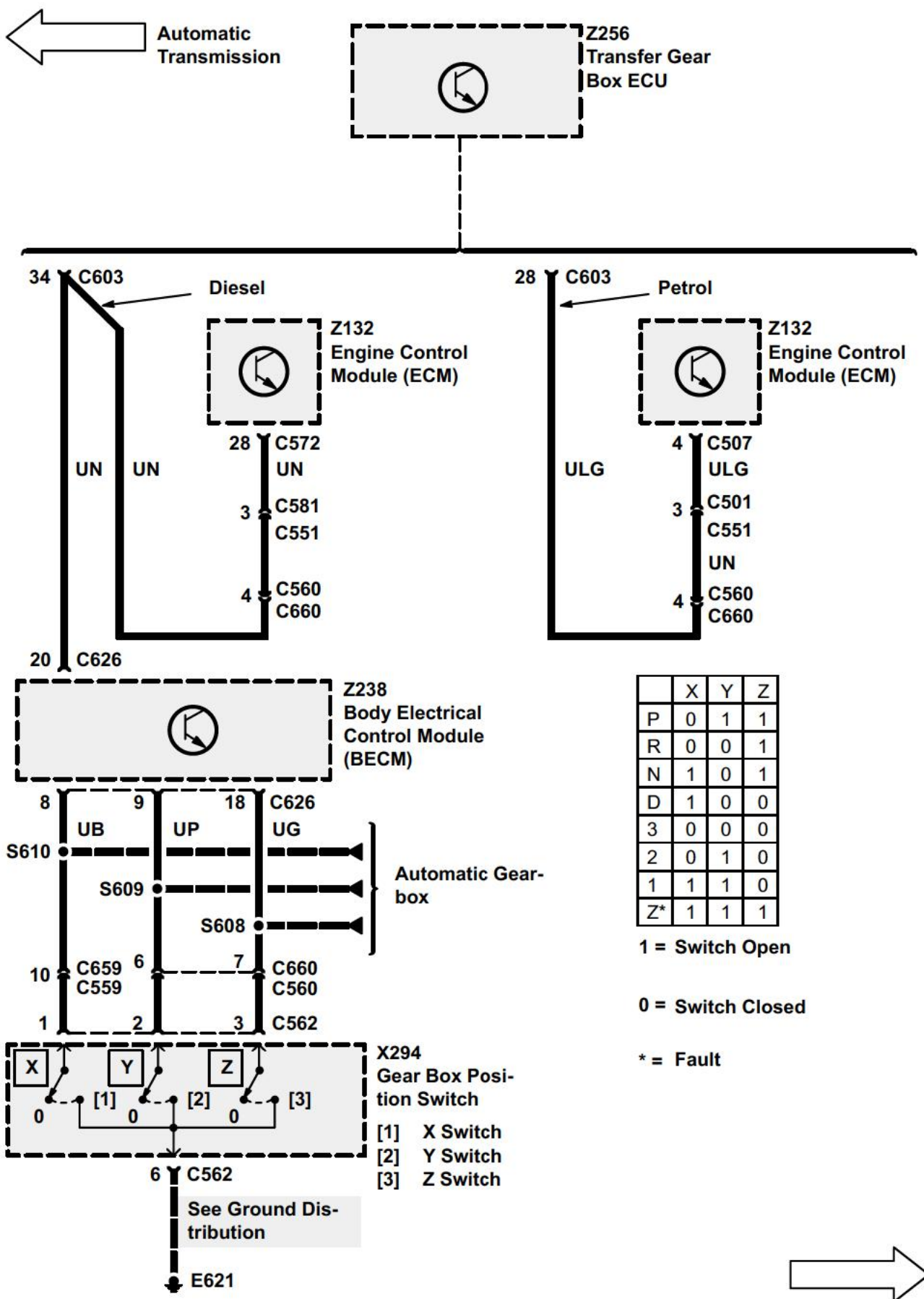

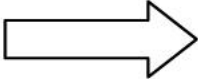
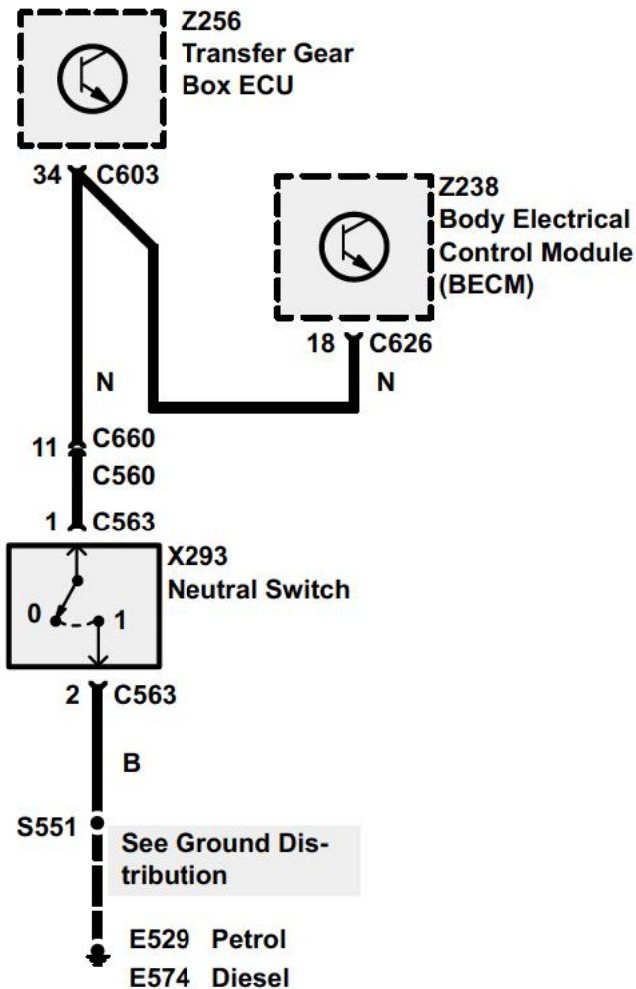
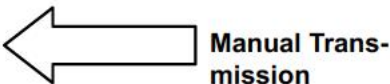

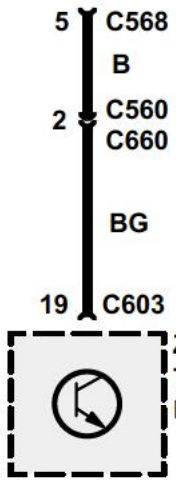
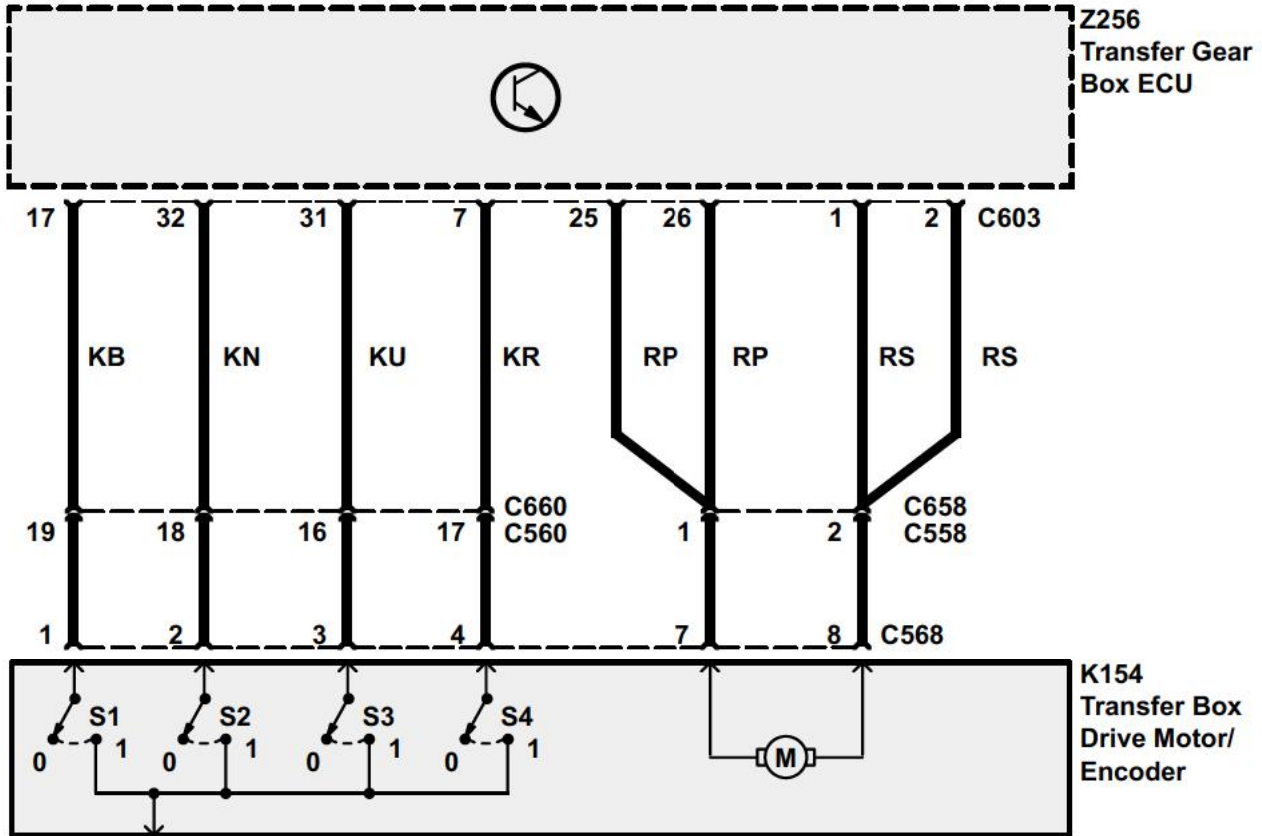
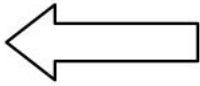

	S1	S2	S3	S4
Left Stop	1	1	1	0
Left of Hi Mode	1	0	1	0
Hi Mode	0	0	1	0
Right of Hi Mode	0	0	0	0
Zone 1	1	0	0	0
Neutral Mode	1	0	0	1
Zone 2	0	0	0	1
Lo Mode	0	1	0	1
Right Stop	0	1	0	0

1 = Switch Open  
0 = Switch Closed

