

## Transfer Box Electrical Components

### Ratio control motor

The ratio control motor is located on the rear casing of the transfer box and secured with four bolts. The motor comprises a conventional single speed permanent magnet type motor. The motor spindle has a worm which engages with a worm wheel in a housing at the end of the motor. The worm wheel is attached to the spindle of the selector interlock spool inside the transfer box.

The worm wheel also drives a motor encoder which comprises four position switches. The transfer box ECU provides a 5 V signal to each switch and interprets the transfer box range by monitoring the condition of each switch.

The transfer box ECU reads the motor position in the form of a binary code with each switch either open or closed circuit. The ECU measures between the switches and an encoder ground on connector pin 19.

By using the combinations of the switches, the transfer box ECU can calculate the transfer box position and how the motor should operate to select the desired range. If the transfer box should move to a position outside the normal condition, i.e. left of high range, the ECU can move the motor to the correct position.

The table below shows the motor switch states and the corresponding motor position for each state.

Switch 1	Switch 2	Switch 3	Switch 4	Motor position
Pin 17	Pin 32	Pin 31	Pin 7	
Open	Open	Open	Closed	Left stop
Open	Closed	Open	Closed	Left of high
Closed	Closed	Open	Closed	High range
Closed	Closed	Closed	Closed	Right of high
Open	Closed	Closed	Closed	Zone 1
Open	Closed	Closed	Open	Neutral
Closed	Closed	Closed	Open	Zone 2
Closed	Open	Closed	Open	Low range
Closed	Open	Closed	Closed	Right stop

### Speed sensor

The speed sensor is located in the rear casing and secured with a screw. A toothed reluctor ring is integrated on the rear output shaft. The inductive speed sensor senses the reluctor ring and produces a sine wave, impulse type signal as each tooth on the reluctor ring passes the sensor.

The transfer box ECU processes the signal from the speed sensor and compares this to a stored speed value in the memory to determine if a range change is allowed.



**NOTE:** The speed sensor is dedicated to the transfer box ECU to determine if a range change can be permitted.



### Temperature sensor

The temperature sensor is screwed into the rear casing. The sensor has two Lucar connectors. One connector is attached to an earth eyelet connector, the other is connected to the BeCM.

When the transfer box oil reaches a temperature of between 140 and 150 °C (284 and 302 °F), contacts in the switch close, completing an earth path to the BeCM. The BeCM uses the completed earth path as a signal to generate a 'TRANSFER OVRHEAT' message in the message centre. The 'TRANSFER OVRHEAT' message is displayed alternately with a 'REFER HANDBOOK' message. When the transfer box oil cools to between 126 and 134 °C (258 and 273 °F), the switch contacts open and the 'TRANSFER OVRHEAT' message is extinguished.

### Transfer box ECU

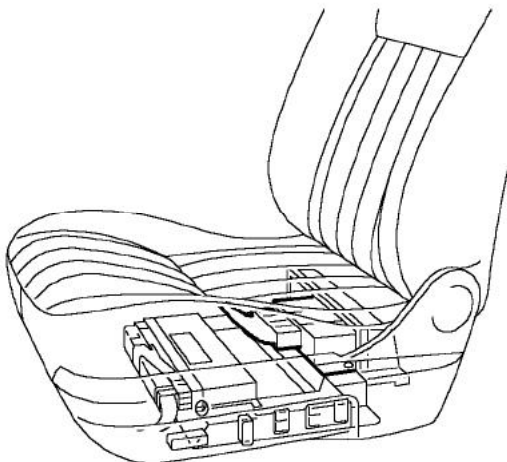

M41 7642

### Transfer box ECU

The transfer box ECU is located below the front LH seat and is identified from the other ECU's located under the seat by its single 36 pin harness connector. The connector supplies power, earth, signal and sensor information to/from the ECU and other ECU's for transmission operation.

The BeCM, located below the right hand front seat, contains its own integral fusebox. The transfer box ECU receives a battery power supply from the BeCM via fuse number 4. An ignition on signal is also supplied from the BeCM via fuse 6. The ignition on signal is supplied to different ECU connector pins for manual and automatic transmission vehicles.

On NAS only vehicles, if a fault occurs which prevents the transfer box moving from low to high range, the transfer box ECU outputs a signal to the ECM which is interpreted as an OBDII fault flag.

The transfer box ECU provides feed and return paths to the ratio control motor to operate the motor in the required direction. Two pins are used to supply power to the motor in each direction. The feed is supplied from two pins to avoid overload and heat generation which would occur if one pin was used. A 5 V signal current is supplied to the four motor encoder switches which are used by the ratio control motor to determine motor position.

Speed signals from the transfer box speed sensor are received as an input to the transfer box ECU which calculates whether the speed is below the threshold to allow a range change.

Range change request signals are received from the H-gate selector switch on automatic transmission vehicles or the high/low switch on manual vehicles.

On automatic transmission vehicles, a park/neutral signal is transmitted from the BeCM to the transfer box ECU. On manual transmission vehicles, a neutral switch located in the transmission provides an earth signal which is used by the ECU and BeCM to determine that the transmission is in neutral. The park/neutral and neutral signal are used by the ECU to allow a range change only when the transmission is in neutral.

Outputs are provided by the transfer box ECU to the BeCM for high and low range status. The BeCM uses the signals for instrument pack message centre display of range status.

## Transfer box ECU connector face view

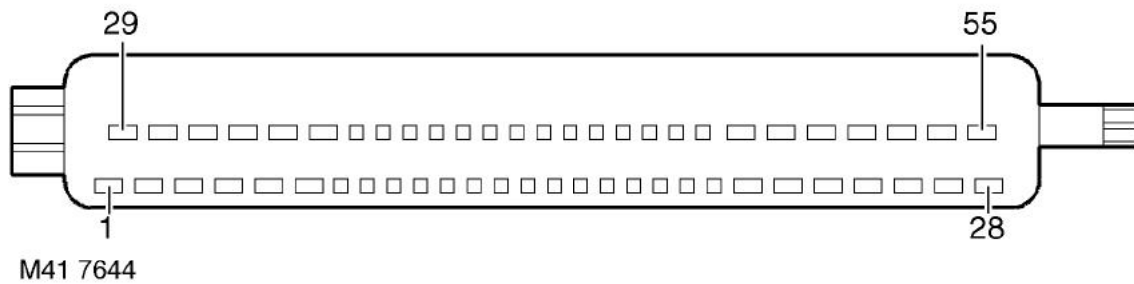

## Transfer box ECU connector pin details

Pin No.	Description	Input/Output
1	Motor drive - Counter clockwise	Output
2	Motor drive - Counter clockwise	Output
3	Not used	-
4	Ignition - Manual vehicles only	Input
5	Power earth	Input
6	Not used	-
7	Motor position switch 4	Input
8 to 12	Not used	-
13	Vehicle speed signal	Input
14	Low range status	Output
15	Transfer box neutral select	Input
16	Not used	-
17	Motor position switch 1	Input
18	Not used	-
19	Motor encoder earth	Output
20	Not used	-
21	Ignition - Automatic vehicles only	Input
22	Not used	-
23	Battery supply	Input
24	Battery supply	Input
25	Motor drive - Clockwise	Output



Pin No.	Description	Input/Output
26	Motor drive - Clockwise	Output
27	Not used	-
28	Transfer box OBDII link	Output
29	Power earth	Input
30	Vehicle speed signal earth	Input
31	Motor position switch 3	Input
32	Motor switch position 2	Input
33	High/Low range select	Input
34	Park/Neutral (Auto) Neutral (Manual) Signal	Input
35	High range status line	Output
36	Neutral range status line	Output

## TRANSFER BOX - OPERATION

### Transfer Box

Drive is transmitted to the transfer box from the gearbox output shaft which is permanently engaged in the sun gear of the epicyclic gear set. In high range the sun gear transmits drive directly to the selector sleeve. In low range, when the selector spool has moved the selector sleeve, the sun gear transmits drive through the planet carrier.

The rotation of the selector sleeve is transferred to the intermediate shaft. A gear attached to the intermediate shaft carries the morse chain which transfers the drive to the differential unit.

The rear output shaft passes through the differential unit and rotates at the same speed. The viscous coupling passes drive from the rear output shaft to the front output shaft. When the silicon fluid in the viscous coupling becomes warm its resistance to shear increases passing more drive to the front drive shaft increasing traction.

### Electrical Operation

#### Range change



**NOTE: Range changes should be performed with the vehicle stationary and although range changes are possible at very low speeds, this practice is not recommended.**

#### Automatic transmission

To change range the vehicle speed must be reduced to below 5 mph (8 km/h). Move the gear selector to neutral and then across the H-gate into the neutral position in the selected range. The appropriate LED illuminations on the selected range side of the selector cover will flash and an audible warning will sound. The flashing LED's and the audible warning will continue while the ratio control motor is moving the transfer box to the selected range.

When the ratio control motor has moved the transfer box into the selected range the LED's will stop flashing, the audible warning will stop and a message is displayed in the message centre. The desired gear can be selected and the vehicle can be driven as required.

If the vehicle is moving above 5 mph (8 km/h) or the selector lever is moved into gear before the range change is complete, the change will not occur and a 'SLOW DOWN' or 'SELECT NEUTRAL' message will be displayed in the message centre.



**NOTE: The 'SLOW DOWN' message is generated by the BeCM, not the transfer box ECU.**

The transfer box can be placed in the 'Neutral' position by moving the selector lever into the 'PARK' position. Insert a spare fuse (minimum 5 Amp) into fuse position 11 on the BeCM. After 5 seconds the transfer box moves to the neutral position, an audible warning will sound, a 'TRANSFER NEUTRAL' message is displayed in the message centre and the high and low LED illumination on the selector cover will extinguish.

#### Manual transmission

To change from high to low the vehicle speed must be below 5 mph (8 km/h) or from low to high the vehicle speed must be below 15 mph (24 Km/h).

Select neutral with the gear lever and press the high/low switch on the fascia. The indicator lamp on the switch will flash as the range change takes place. If the change is from high to low the lamp will continuously illuminate when the change is successfully completed. If the change is from low to high the lamp will extinguish when the change is complete. The message centre displays the selected range.

If a range change is requested and the vehicle is moving too fast or neutral has not been selected, the indicator lamp on the switch will flash and a 'SLOW DOWN' or 'SELECT NEUTRAL' message will appear in the message centre.



**NOTE: The 'SLOW DOWN' message is generated by the BeCM, not the transfer box ECU.**

The transfer box can be placed in the 'Neutral' position by placing the gear lever in neutral and inserting a spare fuse (minimum 5 Amp) into fuse position 11 on the BeCM. After 5 seconds the transfer box moves to neutral, an audible warning will sound and a 'TRANSFER NEUTRAL' message is displayed in the message centre.



### Range information - Automatic transmission

#### High range

When the transfer box is in high range the message centre only displays the selected gear and the high range side of the selector lever cover is illuminated in green.

#### High to low range

When a change from high to low range is requested:

- The low range selector cover LED's flash in orange
- The high range selector cover LED's remain illuminated in green
- The transfer box amber warning lamp in the instrument pack flashes while the range change is taking place.

When the range change is complete:

- The low range selector cover LED's are continuously illuminated in orange
- The high range selector cover green LED illumination goes off
- The transfer box warning lamp goes off
- The message centre displays 'LOW' and after several seconds displays 'L' in front of the selected gear.

#### Low to high range

When a change from low to high range is requested:

- The high range selector cover LED's flash in green
- The low range selector cover LED's remain illuminated in orange
- The transfer box warning lamp in the instrument pack flashes while the range change is taking place.

When the range change is complete:

- The high range selector cover LED's are continuously illuminated in green
- The low range selector cover orange LED illumination goes off
- The transfer box warning lamp goes off
- The message centre displays 'HIGH' for several seconds, then 'HIGH' is removed and only the selected gear is displayed.

#### Range selection parameters incorrect

If a range change is requested and the vehicle speed is too high:

- The LED illumination on the selected side of the cover will flash
- A 'SLOW DOWN' message is displayed in the message centre
- The transfer box warning lamp in the instrument pack flashes.

If a range change is requested and the selector lever is moved before the range change is complete:

- The LED illumination on the selected side of the cover will flash
- A 'SELECT NEUTRAL' message is displayed in the message centre
- The BeCM will initiate an audible warning
- The transfer box warning lamp in the instrument pack flashes.

#### Transfer box to neutral

When a spare fuse (5 Amp minimum) is inserted in BeCM fuse position 11 to select transfer box neutral:

- A five second delay is initiated before the transfer box moves to neutral
- The BeCM initiates an audible warning
- A 'TRANSFER NEUTRAL' message is displayed in the message centre.

**Range information - Manual transmission****High range**

When the transfer box is in high range, the message centre does not display any transmission information and the high/low request switch indicator lamp is off.

**High to low range**

When a change from high to low is requested:

- The high/low switch indicator lamp flashes
- The transfer box warning lamp in the instrument pack flashes.

When the range change is complete:

- The high/low switch indicator lamp is illuminated continuously
- The transfer box warning lamp goes off
- A 'LOW' message is continuously displayed in the message centre.

**Low to high range**

When a change from low to high range is requested:

- The high/low switch indicator lamp flashes
- The transfer box warning lamp in the instrument pack flashes.

When the range change is complete:

- The high/low switch indicator lamp goes off
- The transfer box warning lamp goes off
- The message centre displays 'HIGH' for several seconds.

**Range selection parameters incorrect**

If a range change is requested and the vehicle speed is too high:

- The high/low switch indicator lamp will flash
- The transfer box warning lamp in the instrument pack will flash
- A 'SLOW DOWN' message is displayed in the message centre.

If a range change is requested and the transmission is in gear or a gear selected before range change is complete:

- The high/low switch indicator lamp will flash
- The transfer box warning lamp in the instrument pack will flash
- A 'SELECT NEUTRAL' message is displayed in the message centre for several seconds. If the vehicle remains in gear the message will not be repeated.

**Transfer box to neutral**

When a spare fuse (5 Amp minimum) is inserted in BeCM fuse position 11 to select transfer box neutral:

- A five second delay is initiated before the transfer box moves to neutral
- The BeCM initiates an audible warning
- A 'TRANSFER NEUTRAL' message is displayed in the message centre.