

### Secondary Air Injection System

---

The secondary air injection (SAI) system comprises the following components:

- Secondary air injection pump
- SAI vacuum solenoid valve
- SAI control valves (2 off, 1 for each bank of cylinders)
- SAI pump relay
- Vacuum reservoir
- Vacuum harness and pipes

The secondary air injection system is used to limit the emission of carbon monoxide (CO) and hydrocarbons (HCs) that are prevalent in the exhaust during cold starting of a spark ignition engine. The concentration of hydrocarbons experienced during cold starting at low temperatures are particularly high until the engine and catalytic converter reach normal operating temperature. The lower the cold start temperature, the greater the prevalence of hydrocarbons emitted from the engine.

There are several reasons for the increase of HC emissions at low cold start temperatures, including the tendency for fuel to be deposited on the cylinder walls, which is then displaced during the piston cycle and expelled during the exhaust stroke. As the engine warms up through operation, the cylinder walls no longer retain a film of fuel and most of the hydrocarbons will be burnt off during the combustion process.

The SAI pump is used to provide a supply of air into the exhaust ports in the cylinder head, onto the back of the exhaust valves, during the cold start period. The hot unburnt fuel particles leaving the combustion chamber mix with the air injected into the exhaust ports and immediately combust. This subsequent combustion of the unburnt and partially burnt CO and HC particles help to reduce the emission of these pollutants from the exhaust system. The additional heat generated in the exhaust manifold also provides rapid heating of the exhaust system catalytic converters. The additional oxygen which is delivered to the catalytic converters also generate an exothermic reaction which causes the catalytic converters to 'light off' quickly.

The catalytic converters only start to provide effective treatment of emission pollutants when they reach an operating temperature of approximately 250°C (482°F) and need to be between temperatures of 400°C (752°F) and 800°C (1472°F) for optimum efficiency. Consequently, the heat produced by the secondary air injection "afterburning", reduces the time delay before the catalysts reach an efficient operating temperature.

The ECM checks the engine coolant temperature when the engine is started in addition to the elapsed time since the engine was last started. The engine coolant temperature must be below 55°C (131°F) for the SAI pump to run.

**NOTE: The ambient air temperature must also be above 8°C (46°F) for the SAI pump to run.**

Also, depending on the long term 'modelled' ambient temperature determined by the ECM, the minimum elapsed time required since the last engine start can be up to 8.25 hours. The period of time that the SAI pump runs for depends on the starting temperature of the engine and varies from approximately 96 seconds at 8°C (46°F) to 30 seconds at 55°C (131°F).

Air from the SAI pump is supplied to the SAI control valves via pipework and an intermediate T-piece which splits the air flow evenly to each bank.

At the same time the secondary air pump is started, the ECM operates a SAI vacuum solenoid valve, which opens to allow vacuum from the reservoir to be applied to the vacuum operated SAI control valves on each side of the engine. When the vacuum is applied to the SAI control valves, they open simultaneously to allow the air from the SAI pump through to the exhaust ports. Secondary air is injected into the inner most exhaust ports on each bank.

When the ECM breaks the ground circuit to de-energise the SAI vacuum solenoid valve, the vacuum supply to the SAI control valves is cut off and the valves close to prevent further air being injected into the exhaust manifold. At the same time as the SAI vacuum solenoid valve is closed, the ECM opens the ground circuit to the SAI pump relay, to stop the SAI pump.

A vacuum reservoir is included in the vacuum line between the intake manifold and the SAI vacuum solenoid valve. This prevents changes in vacuum pressure from the intake manifold being passed on to cause fluctuations of the secondary air injection solenoid valve. The vacuum reservoir contains a one way valve and ensures a constant vacuum is available for the SAI vacuum solenoid valve operation. This is particularly important when the vehicle is at high altitude.



## EMISSION CONTROL - V8

The ECM connector and pins pertinent for secondary air injection are listed in the following table:

Connector / Pin No.	Description	Signal type	Control
C0635-23	Main relay output	Output drive	Switch to ground
C0636-4	Secondary air injection vacuum solenoid valve control	Output, drive	Switch to ground
C0636-16	Secondary air injection pump relay control	Output drive	Switch to ground
C0636-21	Coolant temperature (ECT) sensor	Ground	0V
C0636-22	Coolant temperature (ECT) sensor	Input signal	Analogue 0 - 5V
C0637-20	MIL "ON"	Output drive	Switch to ground

### Secondary Air Injection System Components

The secondary air injection (SAI) system components (where fitted) are described below:

#### Secondary Air Injection (SAI) Pump

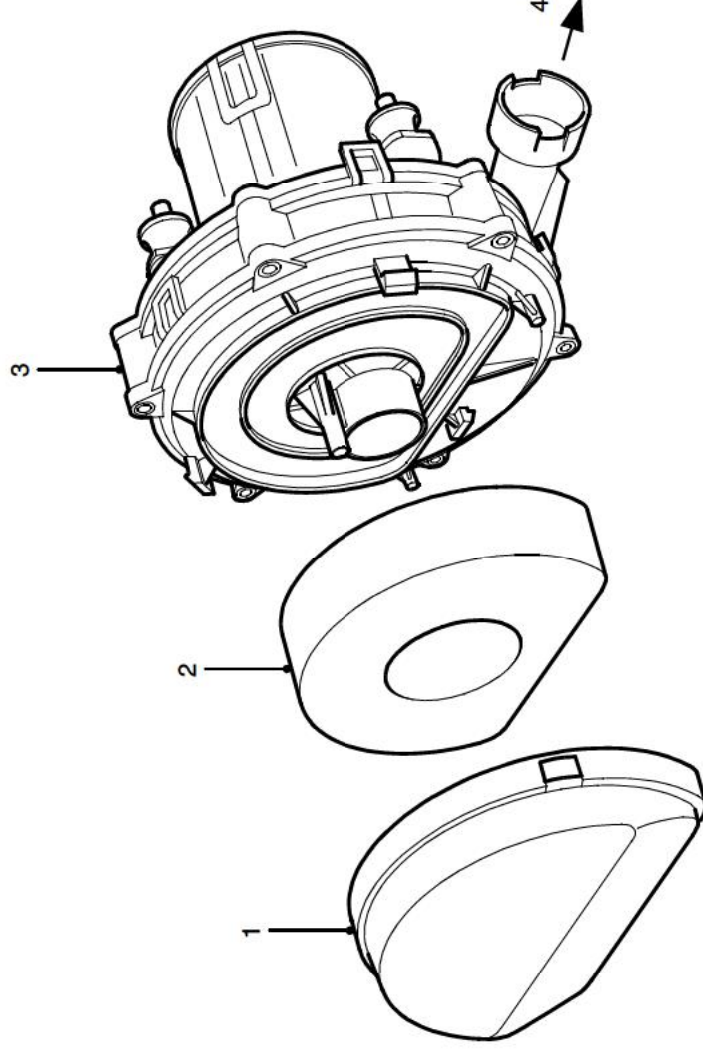

M17 0204

- 1 SAI pump cover
- 2 Foam filter

- 3 SAI pump
- 4 Pressurised air to exhaust manifolds

The SAI pump is attached to a bracket at the rear RH side of the engine compartment and is fixed to the bracket by three studs and nuts. The pump is electrically powered from a 12V battery supply via a dedicated relay and supplies approximately 35kg/hr of air when the vehicle is at idle in Neutral/Park on a start from 20°C (68°F).

Air is drawn into the pump through vents in its front cover and is then passed through a foam filter to remove particulates before air injection. The air is delivered to the exhaust manifold on each side of the engine through a combination of plastic and metal pipes.

## EMISSION CONTROL - V8

The air delivery pipe is a flexible plastic type, and is connected to the air pump outlet via a plastic quick-fit connector. The other end of the flexible plastic pipe connects to the fixed metal pipework via a short rubber hose. The part of the flexible plastic pipe which is most vulnerable to engine generated heat is protected by heat reflective sleeving. The metal delivery pipe has a fabricated T-piece included where the pressurised air is split for delivery to each exhaust manifold via the SAI control valves.

The pipes from the T-piece to each of the SAI control valves are approximately the same length, so that the pressure and mass of the air delivered to each bank will be equal. The ends of the pipes are connected to the inlet port of each SAI control valve through short rubber hose connections.

The T-piece is mounted at the rear of the engine (by the ignition coils) and features a welded mounting bracket which is fixed to the engine by two studs and nuts.

The foam filter in the air intake of the SAI pump provides noise reduction and protects the pump from damage due to particulate contamination. In addition, the pump is fitted on rubber mountings to help prevent noise which is generated by pump operation from being transmitted through the vehicle body into the passenger compartment.

If the secondary air injection (SAI) pump is found to be malfunctioning, the following fault codes may be stored in the ECM diagnostic memory, which can be retrieved using Testbook/T4:

P-code	Description
P0418	Secondary Air Injection System – Relay 'A' circuit malfunction (SAI pump powerstage fault, e.g. - SAI pump relay fault or relay not connected / open circuit / harness damage).

**NOTE:** Refer to 'SAI System Fault Finding' and 'Checking Malfunctions on SAI System' at the end of this section to determine root cause of fault codes.

**NOTE:** The electrical test of the SAI pump powerstage only indicates that there is a problem with the relay or the power supply to the relay. It does not indicate the state of the SAI pump itself (i.e. broken or not connected).

As a result of a SAI pump powerstage malfunction, other fault codes may also become stored in the ECM memory. These may include the following P codes.

**NOTE:** A malfunction of the SAI pump powerstage is logically expected to result in both engine banks reporting the same fault.

P-code	Description
P1412	Secondary Air Injection System – Malfunction Bank 1 LH (Insufficient SAI flow during passive test)
P1414	Secondary Air Injection System – Low air flow Bank 1 LH (Insufficient SAI flow during active test)
P1415	Secondary Air Injection System – Malfunction Bank 2 RH (Insufficient SAI flow during passive test)
P1417	Secondary Air Injection System – Low air flow Bank 2 RH (Insufficient SAI flow during active test)

**NOTE:** Refer to 'SAI System Fault Finding' and 'Checking Malfunctions on SAI System' at the end of this section to determine root cause of fault codes.

### Secondary Air Injection (SAI) Pump Relay

The secondary air injection pump relay is located in the engine compartment fusebox. The engine control module (ECM) is used to control the operation of the SAI pump via the SAI pump relay. Power to the coil of the relay is supplied from the vehicle battery via the main relay and the ground connection to the coil is via the ECM.

Power to the SAI pump relay contacts is via fusible link FL2 which is located in the engine compartment fusebox.



### Secondary Air Injection (SAI) Vacuum Solenoid Valve

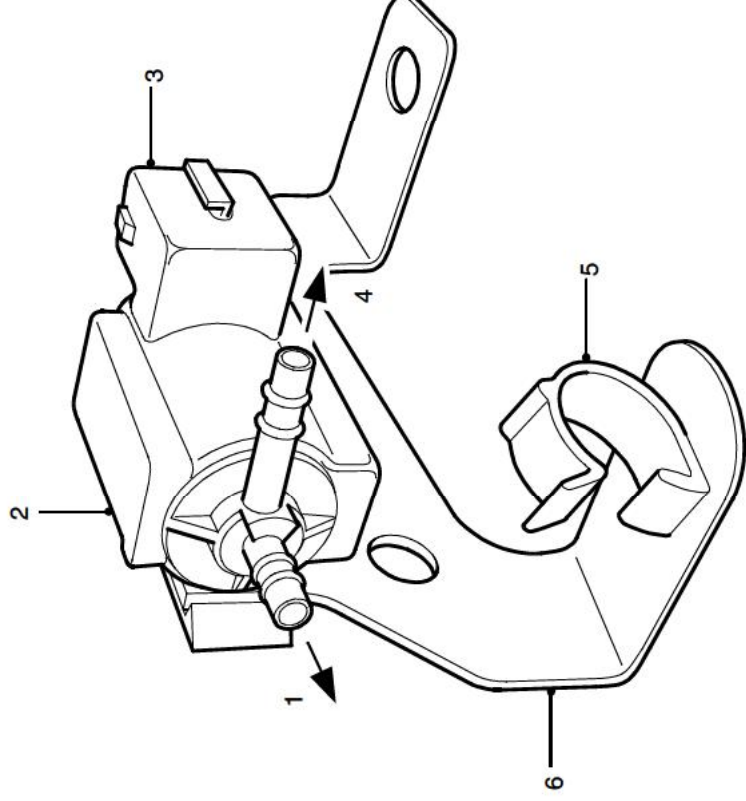

M17 0211

- 1 Vacuum port to intake manifold (via vacuum reservoir)
- 2 SAI vacuum solenoid valve
- 3 Electrical connector

- 4 Vacuum port to vacuum operated SAI control valves
- 5 Purge valve clip
- 6 Mounting bracket

The SAI vacuum solenoid valve is located at the rear LH side of the engine and is electrically operated under the control of the ECM. The SAI vacuum solenoid valve is mounted on a bracket together with the EVAP system purge valve.

Vacuum to the SAI vacuum solenoid valve is provided from the intake manifold depression via a vacuum reservoir. A small bore vacuum hose with rubber elbow connections at each end provides the vacuum route between the vacuum reservoir and SAI vacuum solenoid valve. A further small bore vacuum hose with a larger size elbow connector is used to connect the SAI vacuum solenoid valve to the SAI control valves on each side of the engine via an intermediate connection. The SAI vacuum solenoid valve port to the SAI control valves is located at a right angle to the port to the vacuum reservoir.

The intermediate connection in the vacuum supply line is used to split the vacuum equally between the two SAI control valves. The vacuum hose intermediate connection is located midpoint in front of the inlet manifold. All vacuum hose lines are protected by flexible plastic sleeving.

Electrical connection to the SAI vacuum solenoid valve is via a 2-pin connector. A 12V electrical power supply to the SAI vacuum solenoid valve is provided via the Main relay and Fuse 2 in the engine compartment fusebox. The ground connection is via the ECM which controls the SAI vacuum solenoid valve operation. **Note that the harness connector to the SAI solenoid valve is grey, and must not be confused with the harness connector to the EVAP system purge valve which is black.**

The ECM switches on the SAI vacuum solenoid valve at the same time as initiating SAI pump operation. When the SAI vacuum solenoid valve is open, a steady vacuum supply is allowed through to open the two vacuum operated SAI control valves. When the ECM breaks the earth path to the SAI vacuum solenoid valve, the valve closes and immediately shuts off the vacuum supply to the two SAI control valves at the same time as the SAI pump operation is terminated.

## EMISSION CONTROL - V8

If the SAI vacuum solenoid valve malfunctions, the following fault codes may be stored in the ECM diagnostic memory, which can be retrieved using TestBook/T4:

P-code	Description
P0412	SAI vacuum solenoid valve powerstage fault - harness damage, short circuit to battery supply voltage
P0413	SAI vacuum solenoid valve not connected, open circuit
P0414	SAI vacuum solenoid valve short circuit to ground

**NOTE:** Refer to 'SAI System Fault Finding' and 'Checking Malfunctions on SAI System' at the end of this section to determine root cause of fault codes.

As a result of the SAI vacuum solenoid malfunction, other fault codes may also be stored in the ECM diagnostic memory. These may include the following:

**NOTE:** A malfunction of the valve is logically expected to result in both engine banks reporting the same fault.

P-code	Description
P1412	Secondary Air Injection System – Malfunction Bank 1 LH (Insufficient SAI flow during passive test)
P1413	Secondary Air Injection System – Air control valve always open Bank 1 LH (Excessive SAI flow during active leak test)
P1414	Secondary Air Injection System – Malfunction Bank 1 LH (Insufficient SAI flow during passive test)
P1415	Secondary Air Injection System – Malfunction Bank 2 RH (Insufficient SAI flow during passive test)
P1416	Secondary Air Injection System – Air control valve always open Bank 2 RH (Excessive SAI flow during active leak test)
P1417	Secondary Air Injection System – Low air flow Bank 2 RH (Insufficient SAI flow during active test)

**NOTE:** Refer to 'SAI System Fault Finding' and 'Checking Malfunctions on SAI System' at the end of this section to determine root cause of fault codes.



## EMISSION CONTROL - V8

## SAI Control Valves

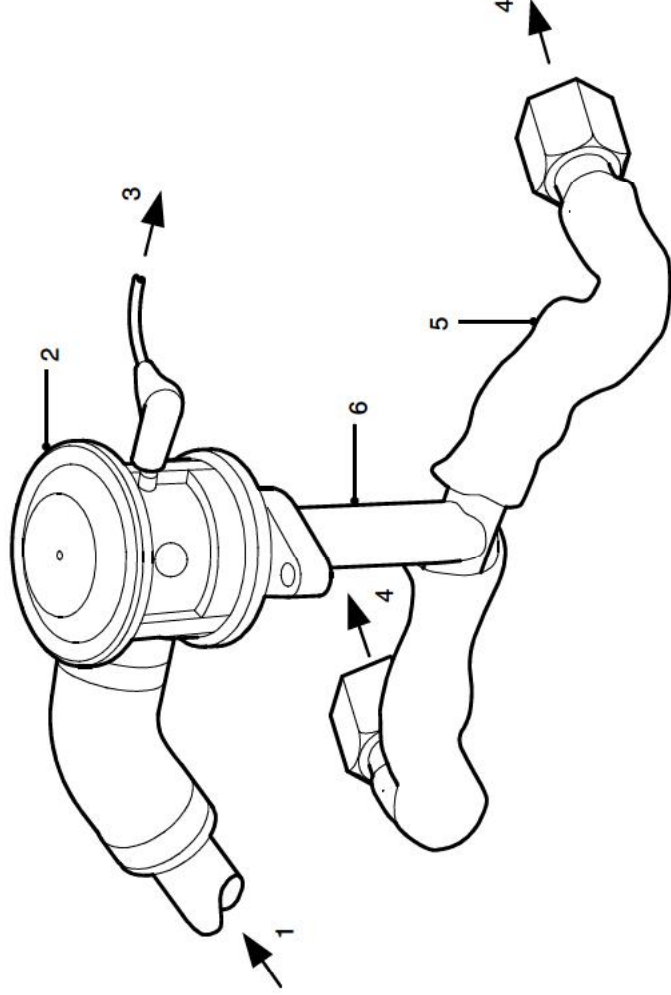

M17 0205

- 1 Pressurised air from SAI pump
- 2 Vacuum operated SAI control valve
- 3 Vacuum hose from SAI vacuum solenoid valve
- 4 Pressurised air to exhaust manifold
- 5 Protective heat sleeving
- 6 Air delivery pipe to exhaust manifold

The SAI control valves are located on brackets at each side of the engine.

The air injection supply pipes connect to a large bore port on the side of each SAI control valve via a short rubber connection hose. A small bore vacuum port is located on each SAI control valve at the opposite side to the air injection supply port. The vacuum supply to each vacuum operated SAI control valve is through small bore nylon hoses from the SAI vacuum solenoid valve. An intermediate connector is included in the vacuum supply line to split the vacuum applied to each vacuum operated valve, so that both valves open and close simultaneously.

When a vacuum is applied to the SAI control valves, the valve opens to allow the pressurised air from the SAI pump through to the exhaust manifolds. The injection air is output from each SAI control valve through a port in the bottom of each unit. A metal pipe connects between the output port of each SAI control valve and each exhaust manifold via an intermediate T-piece. The T-piece splits the pressurised air delivered to ports at the outer side of the two centre exhaust ports on each cylinder head. The pipes between the T-piece and the exhaust manifold are enclosed in thermal sleeving to protect the surrounding components from the very high heat of the exhaust gas, particularly at high engine speeds and loads.

When the SAI vacuum solenoid valve is de-energised, the vacuum supply line opens to atmosphere, this causes the vacuum operated valves to close automatically and completely to prevent further air injection.

As a result of SAI control valve malfunction, certain fault codes may be stored in the ECM diagnostic memory, which can be retrieved using Testbook/T4. These may include the following::