

FUSE DETAILS

ENGINE COMPARTMENT FUSE BOX

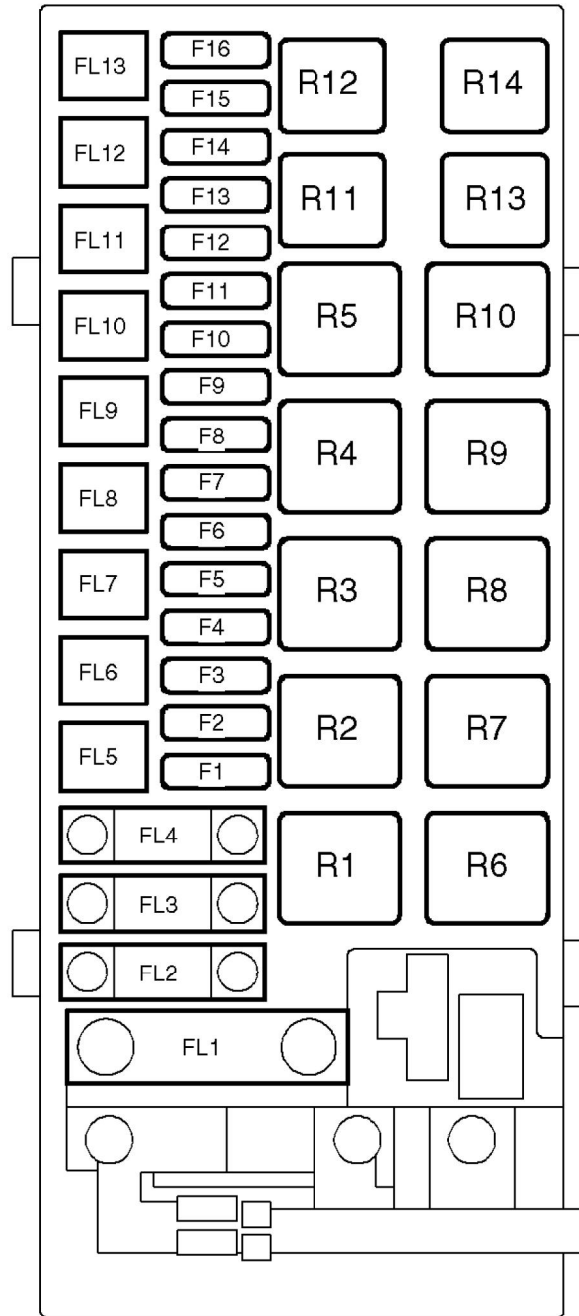

M86 4472

Relays (R)

1. Fuel pump
2. Starter
3. Headlamp powerwash
4. Cooling fan
5. Self Levelling/ABS (SLABS)
6. Glowplugs - Diesel only
7. Auxiliary circuits
8. Heated Front Screen (HFS)
9. Main relay
10. Anti-lock Braking System (ABS)
11. Compressor clutch (A/C only)
12. Front fog lamps
13. Horns
14. Active Cornering Enhancement (ACE)

Link	Rating	Vehicle	Function
FL1	150 A	ALL	Fusible links 4, 5, 6 and 7, fuses 3, 4, 5, and 6 of the engine compartment fuse box, and the HFS relay.
FL2	100 A	Td5	Glow plug relay.
FL3	50 A	ALL	Fuses 1, 2, 20 and 21 of the passenger compartment fuse box.
FL4	100 A	ALL	Fuses 6 and 7 of the passenger compartment fuse box.
FL5	50 A	ALL	RH seat relay, LH seat relay, and fuse 34 of the passenger compartment fuse box.
FL6	50 A	ALL	Fuses 8, 12 and 13 of the passenger compartment fuse box.
FL7	30 A	ALL	Auxiliary relay and fuse 17 of the passenger compartment fuse box.
FL8	50 A	ALL	Ignition switch and the ignition relay.
FL9	30 A	ALL	SLABS relay.
FL10	40 A	ALL	Lighting switch, fuses 4 and 5 of the passenger compartment fuse box.
FL11	30 A	ALL	ABS return pump relay.
FL12	30 A	ALL	Starter relay.
FL13	30 A	ALL	Lighting switch.

FUSE DETAILS

Fuse	Rating	Vehicle	Function
F1	30 A	Td5	ECM
F1	30 A	V8	ECM, fuel injectors, IACV, idle suppressor solenoid.
F2	15 A	Td5	EGR modulator, EGR throttle, MAF sensor, RH front HO2S, RH rear HO2S, LH front HO2S, LH rear HO2S.
F2	15 A	V8	Purge control valve, CMP sensor, MAF sensor, RH front HO2S, RH rear HO2S, LH front HO2S, LH rear HO2S.
F3	15 A	All	Front fog lamp relay.
F4	20 A	All	Headlamp power wash relay.
F5	40 A	All	Cooling fan relay.
F6	10 A	All	A/C compressor clutch relay.
F7	40 A	All	LH HFS element.
F8	40 A	All	RH HFS element.
F9	30 A	Td5	FBH
F10	30 A	All	Fuel pump relay.
F11	30 A	All	SLABS ECU
F12	20 A	Td5	EAT ECU.
F12	20 A	V8	EAT ECU, ECM.
F13	10 A	All	Inertia switch, BCU, IDM, instrument pack.
F14	15 A	All	IDM
F15	15 A	All	ACE relay.
F16	10 A	All	Horn relay.