

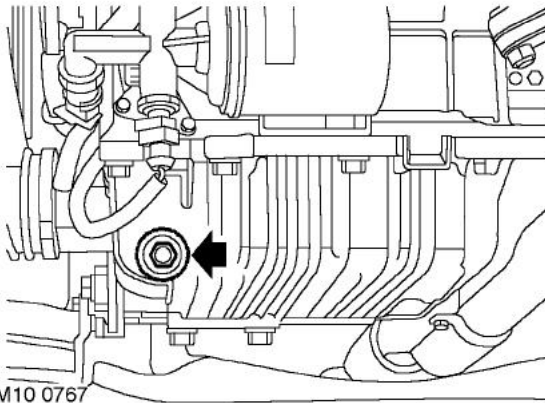

Engine Oil and Filter – K1.8

Drain

1. Raise vehicle on ramp.
2. Remove underbelly panel.
 **EXTERIOR FITTINGS, REPAIRS, Panel - underbelly.**





3. Place a suitable container under engine sump drain plug, remove plug and discard sealing washer. Allow oil to drain.

WARNING: Observe due care when draining engine oil as the oil can be very hot.

WARNING: Avoid excessive skin contact with used engine oil. Used engine oil contains potentially harmful contaminants which may cause skin cancer or other serious skin disorders.

4. Remove and discard engine oil filter.

Refill

1. Lubricate sealing ring of new filter with clean engine oil.
2. Fit new filter and tighten by hand until it seats, then tighten a further half a turn.
3. Clean sump drain plug and fit new sealing washer.
4. Fit sump drain plug and tighten to 25 Nm (18 lbf.ft).
5. Remove engine oil filler cap and fill engine with oil to correct level.
 **CAPACITIES, FLUIDS, LUBRICANTS AND SEALANTS, Lubrication.**
6. Fit oil filler cap.
7. Fit underbelly panel.
 **EXTERIOR FITTINGS, REPAIRS, Panel - underbelly.**
8. Lower vehicle.
9. Start engine. Run at idle until oil pressure warning light extinguishes.
10. Stop engine. Recheck engine oil level.
11. Check for signs of leakage.