

Wheel Changing

CHANGING A WHEEL

Positioning the jack - right-hand side

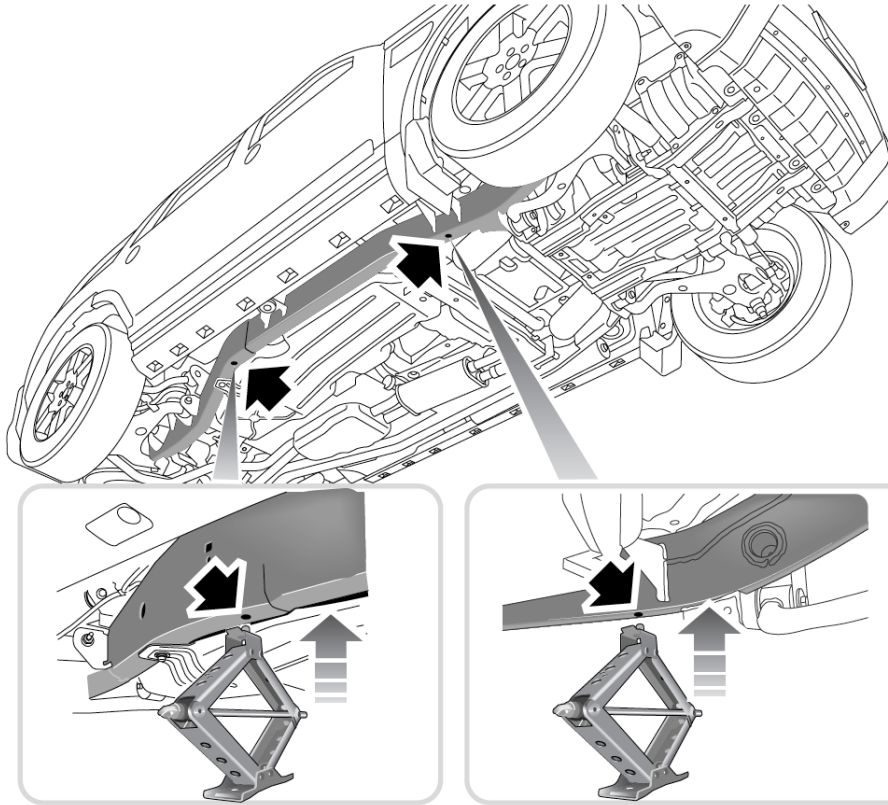

H5693G

Note: Before positioning the jack under the vehicle, ensure that the air suspension is set to Off-road height.

WARNING

NEVER work beneath the vehicle with the jack as the only means of support. The jack is designed for wheel changing only.

Always remove the spare wheel before jacking up the vehicle.

WARNING

ALWAYS:

- Place the jack on firm level ground.
- Position the jack from the side of the vehicle, in line with the appropriate jacking point.
- Raise the jack so that the pin in the head of the jack engages with a hole in the chassis rail at the points shown in the illustrations.