

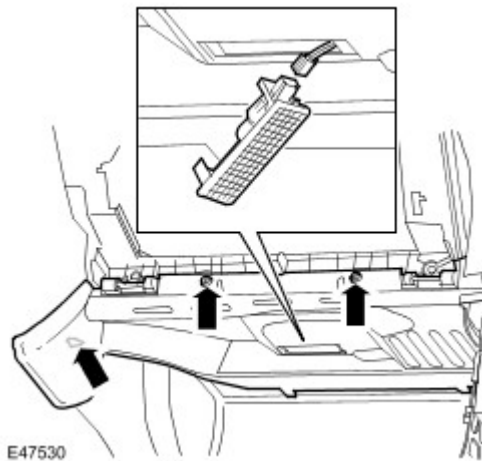

Instrument Panel Passenger Side Reinforcement (76.46.32)

Removal

1. Remove the instrument panel center reinforcement. For additional information, refer to [Instrument Panel Center Reinforcement \(76.46.34\)](#) (Section 501-12)
2. Remove the PAD switch. For additional information, refer to [Passenger Air Bag Deactivation \(PAD\) Switch \(76.74.19\)](#) (Section 501-20)
3. Remove the glove compartment. For additional information, refer to [Glove Compartment \(76.52.03\)](#) (Section 501-12)
4. Remove the closing trim panel.
 - ▶ Release the clip.
 - ▶ Remove the 2 screws.
 - ▶ Disconnect the electrical connector.



5. Remove the passenger side footwell duct.
 - ▶ Remove the clip.

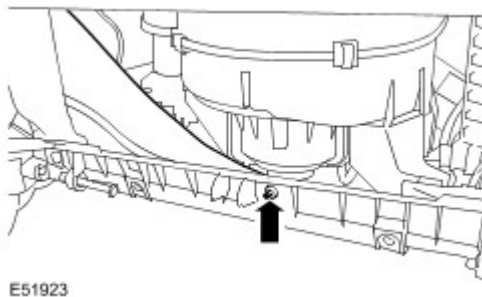

6. Remove the stowage compartment tray.
 - ▶ Release the 4 clips.



7. Remove the instrument panel passenger side reinforcement.

- ▶ Remove the 11 Torx screws.
- ▶ Disconnect the electrical connector.

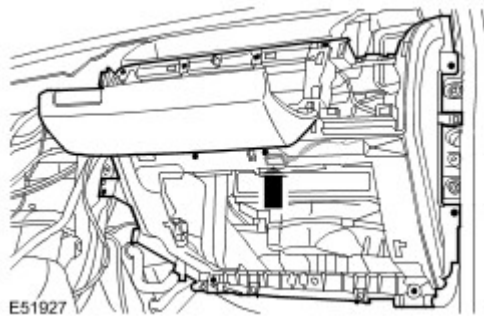

8. **NOTE :**
Do not disassemble further if the component is removed for access only.
Remove the glove compartment lamp.

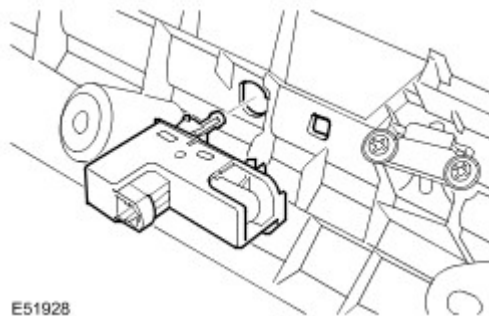

9. Remove the glove compartment damper.

- ▶ Remove the Torx screw.

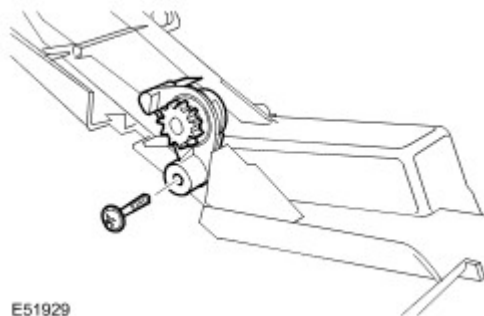

10. **NOTE :**
 Note the position of the hinge pin and spring prior to removal.
 Remove the stowage compartment lid.
- ▶ Remove the 2 hinge pins.
 - ▶ Release the 2 hinge springs.
 - ▶ Remove the Torx screw and remove the damper.

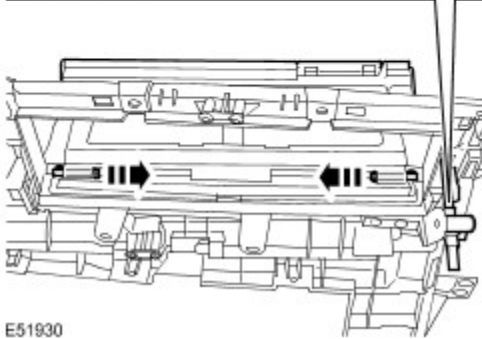
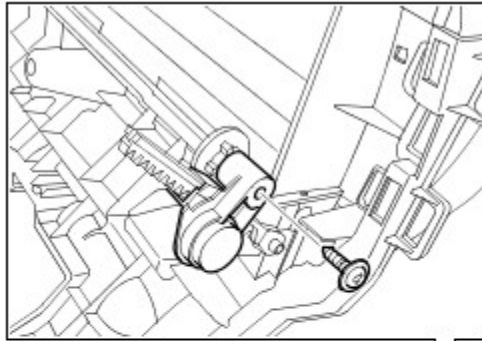

E51930

11. Remove the glove and stowage compartment strikers.
- ▶ Remove the 4 Torx screws.

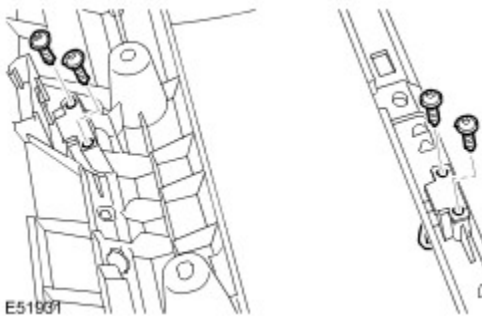

E51931

Installation

1. Install the glove compartment damper.
 - ▶ Tighten the Torx screw.
2. Install the stowage compartment lid.
 - ▶ Install the damper and tighten the Torx screw.

- ▶ Attach the hinge springs.
- ▶ Install the hinge springs.
- 3 . Install the glove and stowage compartment strikers.
 - ▶ Tighten the screws.
- 4 . Install the glove compartment lamp.
- 5 . Install the instrument panel passenger side reinforcement.
 - ▶ Connect the electrical connector.
 - ▶ Tighten the Torx screws.
- 6 . Install the passenger side footwell duct.
 - ▶ Install the clip.
- 7 . Install the closing trim panel.
 - ▶ Connect the electrical connector.
 - ▶ Secure the clip.
- 8 . Install the stowage compartment tray.
 - ▶ Secure the clips.
- 9 . Install the glove compartment. For additional information, refer to [Glove Compartment \(76.52.03\)](#) (Section 501-12)
- 10 . Install the PAD switch. For additional information, refer to [Passenger Air Bag Deactivation \(PAD\) Switch \(76.74.19\)](#) (Section 501-20)
- 11 . Install the instrument panel center reinforcement. For additional information, refer to [Instrument Panel Center Reinforcement \(76.46.34\)](#) (Section 501-12)