



Selector Lever Cable Adjustment (44.30.04)

1 .



WARNING: The hand brake and foot brake MUST BE applied.

Check for correct cable adjustment.

- Move the selector lever from 'P' position, check engagement in each position and return to 'P'.
- Check that the engine will start in 'P' and 'N' positions and that the engine start is inhibited when drive positions are selected.

2 .



WARNING: Do not work on or under a vehicle supported only by a jack. Always support the vehicle on safety stands.

Raise and support the vehicle.

3 . Remove the transmission undershield.

- Remove the 6 bolts.

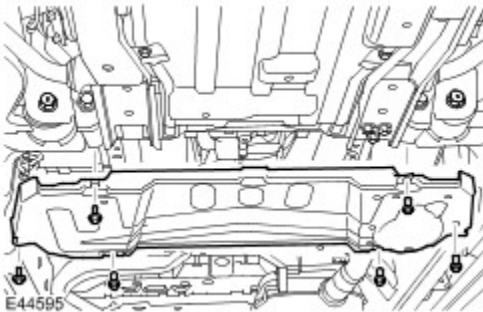

4 . If installed, remove the transmission heat shield.

- Remove the 4 bolts.

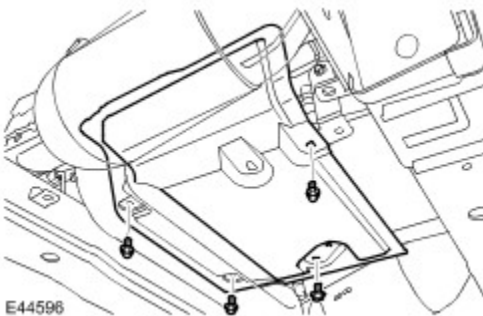

5 . Adjust the selector cable.

- Using an additional wrench, restrain the clamping bush and loosen the locknut.

- Move the selector lever on the gearbox fully forward and release it. The lever will return to the 'P' position.
- Make sure the selector lever is in the 'P' position.
- Push the cable inner rearward then release it.
- Tighten the locknut to 10 Nm (7 lb.ft).

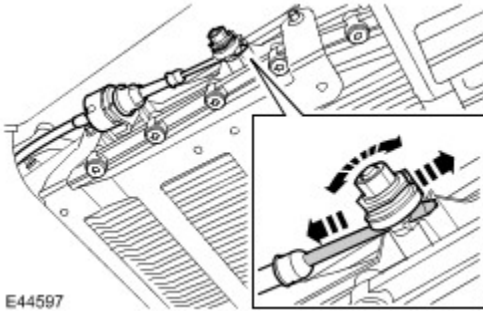

6 .



WARNING: The hand brake and foot brake MUST BE applied.

Check for correct cable adjustment.

- Move the selector lever from 'P' position, check engagement in each position and return to 'P'.
- Check that the engine will start in 'P' and 'N' positions and that the engine start is inhibited when drive positions are selected.

7 . If installed, install the transmission heat shield.

- Tighten the bolts to 10 Nm (7 lb.ft).

8 . Install the transmission undershield.

- Tighten the bolts to 10 Nm (7 lb.ft).