

## Mechatronic Replacement Hints ZF transmission LifeguardFluid

**The CTSC**  
the california transmission  
supply company, LLC



### Notes on transmission fluid

- Use of **ANY** transmission fluid other than ZF LifeguardFluid can cause transmission slippage, harsh shifting, noise, lock-up clutch cycling and reduced service life.

#### LifeguardFluid6 S671 090 255

all 6HP19,  
all 6HP19X **except for Audi Q7**,  
all 6HP21, 6HP21X, 6HP26, 6HP26X,  
all 6HP26A61(2) **except vehicles with Audi W12-engine**  
all 6HP28, 6HP28X, 6HP28A61,  
all 6HP32, 6HP32A (2), 6HP32X

#### LifeguardFluid6+ S671 090 281

6HP26A61(2) **for vehicles with Audi W12-engine**

#### LifeguardFluid8 AA00 601 304

all 6HP19A (2)  
6HP19X **for Audi Q7**  
all 6HP28AF (2)

(2) differential require different oil, see TE-ML11 for specifications.

## Mechatronic Replacement Hints

### Fluid level procedures

#### **Transmissions fluid level checking.**

- The transmission fluid temperature must be between 30 °C and 35 °C before checking can begin.
- Use test equipment to determine the trans temperature.
- The vehicle must be level with engine running at idle speed and air conditioning turned on.
- Step on the brakes firmly, apply parking brake fully and shift to D and R, briefly pausing in each position before shifting back to the Park position.
- With the engine running at idle speed and the selector in Park position, remove the filler plug.
- Monitor the transmission temperature, if a small stream of oil runs out at 40 °C, the fluid level is correct.
- If no oil runs out when the filler plug is removed, the fluid level is too low and oil needs to be added until it overflows.
- With engine running, install the oil filler plug and tighten to proper torque.

#### **Adding fluid after repairs.**

- With the engine stopped and the transmission in Park position, remove the oil filler plug. Add transmission fluid until a small stream of oil runs out.
- Insert the filler plug and tighten by hand. Start the engine.
- With the engine running, remove the oil filler plug and add transmission fluid until a small stream of oil runs out. Insert the filler plug and tighten by hand.
- Follow the “Transmission fluid level checking” procedure described in section **Transmission fluid level checking** above.

## Mechatronic Replacement Hints

### Fluid level procedures

---

#### **Notes on fluid level and adding procedure.**

- Use only ZF-LifeguardFluid6 or OE approved transmission fluid.
- If the transmission temperature rises above 50 °C during the fluid level checking procedure the resulting oil level will be to low. Let the transmission cool down and repeat the fluid level procedure.
- Have transmission fluid and a suitable oil pump available before starting the fluid level procedure. The transmission fluid temperature will rise quickly during the checking procedure.



## Mechatronic Replacement Hints

Drain and filler plug location for 6HP19X/21X with plastic oil pan

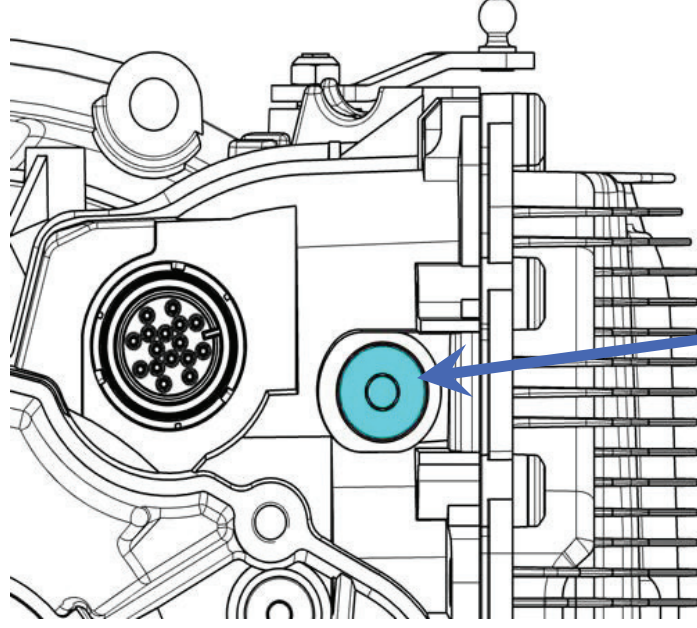

Filler plug **M18x1.5**  
Inner hexagon **8mm**  
Tightening torque **35 Nm ± 3.5 Nm**

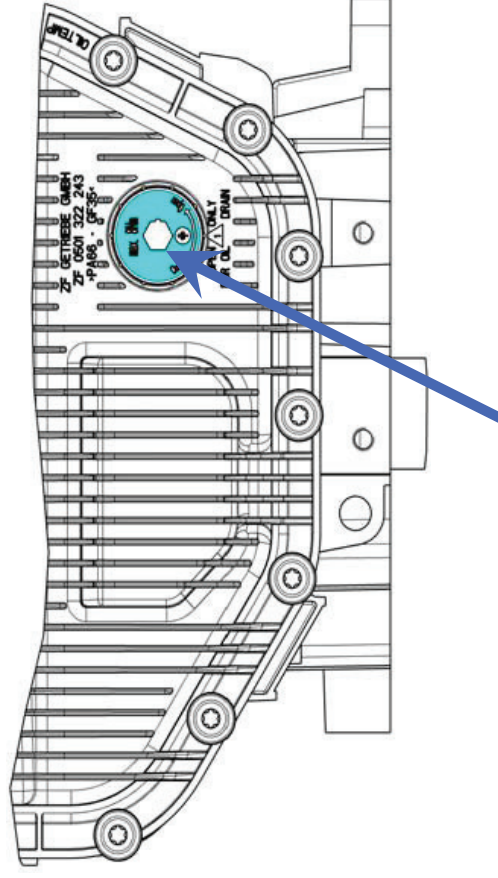

Drain plug **M24x1**  
Inner hexagon **10mm**  
Tightening torque **8 Nm - 0.5 Nm**

## Mechatronic Replacement Hints

Drain and filler plug location for 6HP26/28/32 with plastic oil pan

**The CTSC**

the california transmission  
supply company, LLC

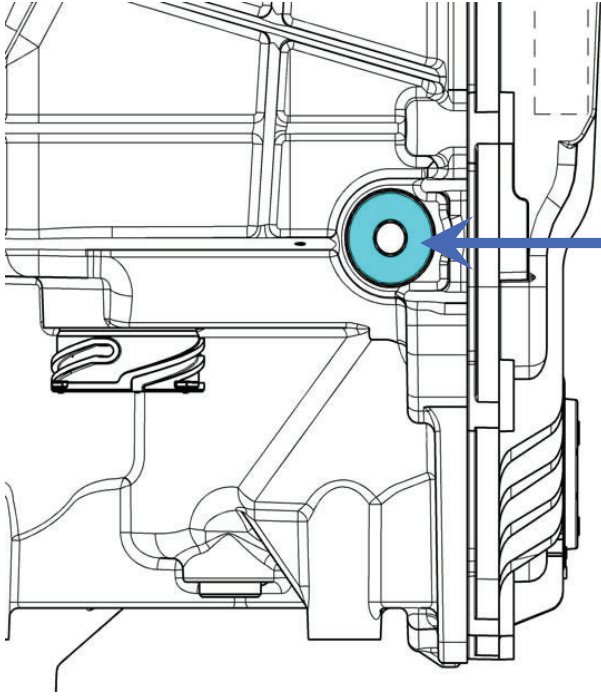

Filler plug **M18x1.5**  
Inner hexagon **8mm**  
Tightening torque **35 Nm ± 3.5 Nm**

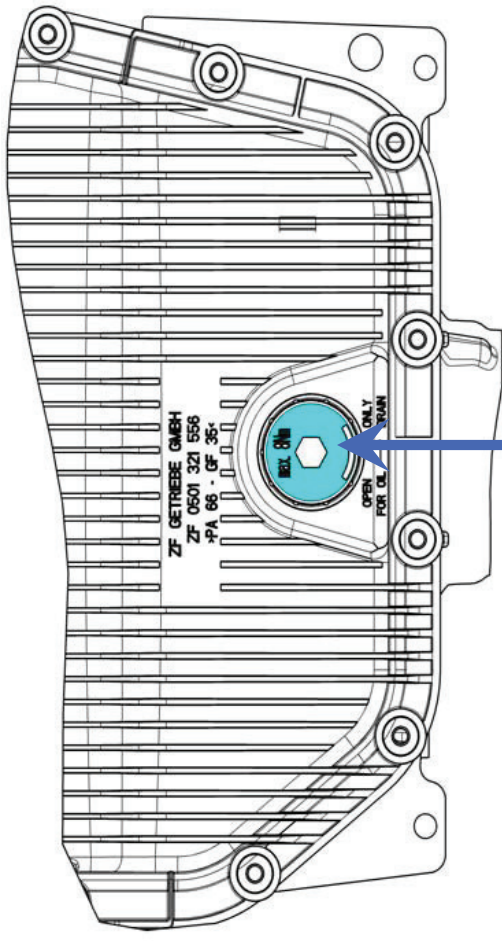

Drain plug **M24x1**  
Inner hexagon **10mm**  
Tightening torque **8 Nm - 0.5 Nm**

## Mechatronic Replacement Hints

Drain and filler plug location for 6HP26X with steel oil pan

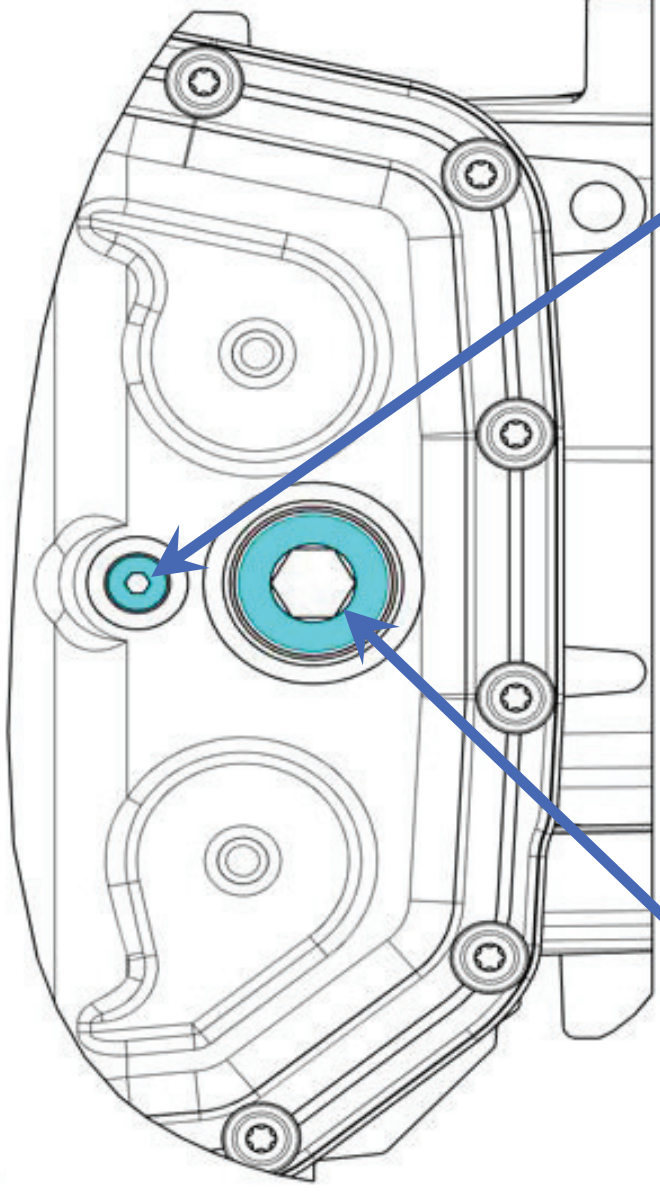

Drain plug **M10x1**  
Inner hexagon **5mm**  
Tightening torque **12 Nm ± 1.2 Nm**

Filler plug **M30x1.5**  
Inner hexagon **17mm**  
Tightening torque **80 Nm ± 8 Nm**