

# Handles, Locks, Latches and Entry Systems - Handles, Locks, Latches and Entry Systems

Description and Operation

Passive Entry - Antenna and Keyless Vehicle Module Location

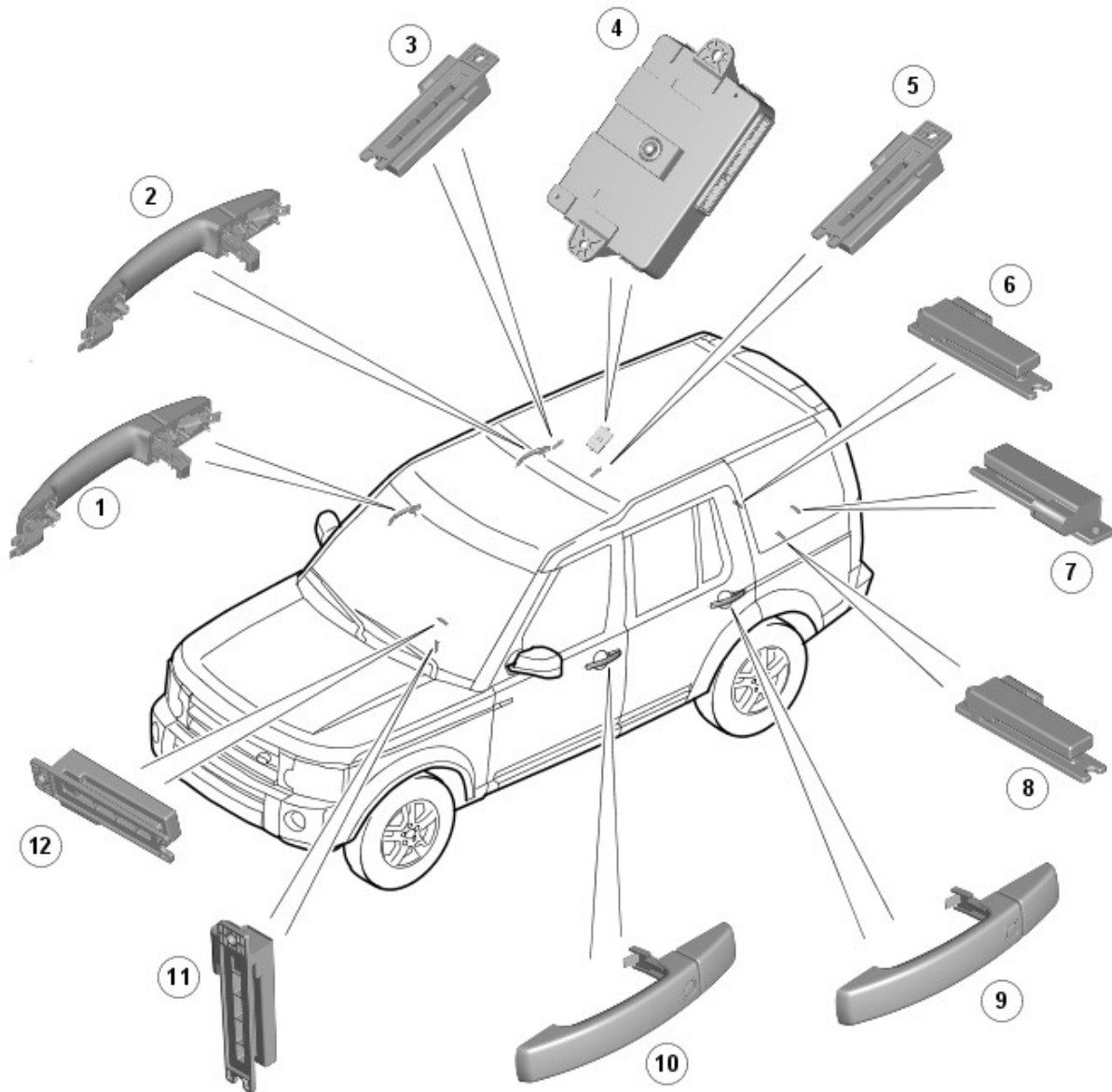

E130381

Item	Part Number	Description
1	-	Door Antenna - right-hand-front
2	-	Door Antenna - right-hand-rear
3	-	Interior Antenna - roof lining
4	-	Keyless Vehicle Module
5	-	Interior Antenna - roof lining
6	-	Interior Antenna - luggage compartment
7	-	Bumper Antenna - rear bumper
8	-	Interior Antenna - luggage compartment
9	-	Door Antenna - left-hand-rear
10	-	Door Antenna - left-hand-front
11	-	Interior Antenna - front compartment (passive start only)
12	-	Interior Antenna - front compartment

## OVERVIEW

The hinged panels are secured with latches and strikers. A remotely operated central locking system controls the locking

and unlocking of the door and luggage compartment latches.

A radio frequency Smart Key allows the vehicle to be locked and unlocked by pressing the appropriate handset buttons. Two levels of central locking system are available:

- Remote central locking, and an
- optional passive entry.

The passive entry and associated passive start system allows the driver to unlock and start the vehicle without using a vehicle key in a door-lock or ignition switch. The passive entry system is an optional fitment while the passive start system is a standard fitment on all vehicles. The passive start system is combined with the passive anti-theft immobilization system.

For additional information, refer to: [Anti-Theft - Passive](#) (419-01B Anti-Theft - Passive, Description and Operation).

Emergency access to the vehicle is provided by a concealed key barrel located in the front left-hand door handle. The key barrel is concealed by a plastic cover which can be removed by inserting the blade of the emergency key into a slot in the cover. The removable emergency key blade is located in the Smart Key.

Operation of the key barrel unlocks the vehicle but does not disarm the alarm system. Locking and unlocking conditions using the emergency key in the door key barrel are:

- If the alarm is not armed the vehicle can be centrally unlocked.
- If the alarm is armed the door only can be opened and the alarm will be triggered.
- The vehicle cannot be double locked or the alarm system armed using the emergency key.

The vehicle can be centrally locked and unlocked from inside using the interior handle release levers on the front doors only. The driver can select locking options, single point entry or drive away locking for example, from a menu available on the touch screen.

### **Central Locking – Radio Frequency Remote System**

The radio frequency central locking system provides locking and unlocking from inside the vehicle and outside within a 20 meter range. The system is operated using buttons on the Smart Key, which transmits radio frequency signals to the radio frequency receiver.

Additional buttons on the Smart Key provide for the convenience operation of the headlamp delay, panic alarm and tailgate release.

Depending on vehicle market, functions offered by the Smart Key include:

- Double locking the doors from outside the vehicle if the lock button on the Smart Key is pressed twice within 3 seconds.
- Drive-away locking - switched on or off by the customer using the vehicle security settings menu available on the touch screen.
- Single or two stage unlocking - single-stage unlocking unlocks all doors with a single press; two-stage unlocking unlocks the driver's door only with a single press and all other doors with a second press.

Changing the unlocking mode between single stage and two-stage also affects the unlocking mode for passive entry (see below). The single or two-stage unlocking function can be switched on or off, as can remote global open or close for the electric windows using the vehicle security settings menu available on the touch screen.

The fuel filler flap is locked by the global locking function. It is not locked by drive-away locking, or if doors are locked from inside the vehicle using the handles.

Actuated from the front door levers only, the doors can be locked from inside the vehicle by pressing the interior door release levers inwards and unlocked by pulling the levers. The touch-screen incorporates a valet mode feature which inhibits access to the glove box while also limiting the use of the touch-screen.

On leaving the vehicle with passive entry the user must press an external button on the door handle once to centrally lock the vehicle or twice within 3 seconds to double lock. The user has a further 3 seconds to pull the door handle to check the vehicle is locked without the Smart Key proximity function unlocking the door again. Pulling the handle after the 3 seconds has lapsed will unlock the door as normal.

If any aperture is not fully closed when the locking process is initiated, either passively or by the Smart Key transmitter, the locking function will be inhibited and an audible error indication will be given. If the ignition is left on an audible warning will be given if the user exits the vehicle, if the user attempts to lock the vehicle (ignition on), another audible indication will be given, and the locking function will be inhibited.

If the door is closed without locking and no key left in the car the ignition will be switched off immediately. If the ignition is left on at any time without starting the vehicle it will switch off automatically after 60 minutes.

If the door is opened by the mechanical key, the full alarm system will sound until the user enters the vehicle and presses either:

- the start/stop button, or
- Smart Key unlock button.

• **NOTE:** If the KVM (keyless vehicle module) fails to locate the Smart Key, a message 'SMART KEY NOT FOUND REFER TO HANDBOOK' will appear in the instrument cluster message center and the keyless start back-up process will have to be used to mobilize and start the vehicle.

### **Keyless Start Backup**

If the vehicle has been unlocked using the emergency key blade or the Smart Key is not detected by the vehicle, it will be necessary to use the keyless start backup to disarm the alarm and start the engine. The following process must be followed in this event:

- Position the Smart Key against the underside of the fascia, on the outboard side of the steering column, with the buttons facing downwards. This is the location of the IAU (immobilizer antenna unit).
- Holding the Smart Key in position and the brake / clutch pedal depressed, press the start/stop button to start the engine.

Smart Key positioned next to immobilizer antenna unit

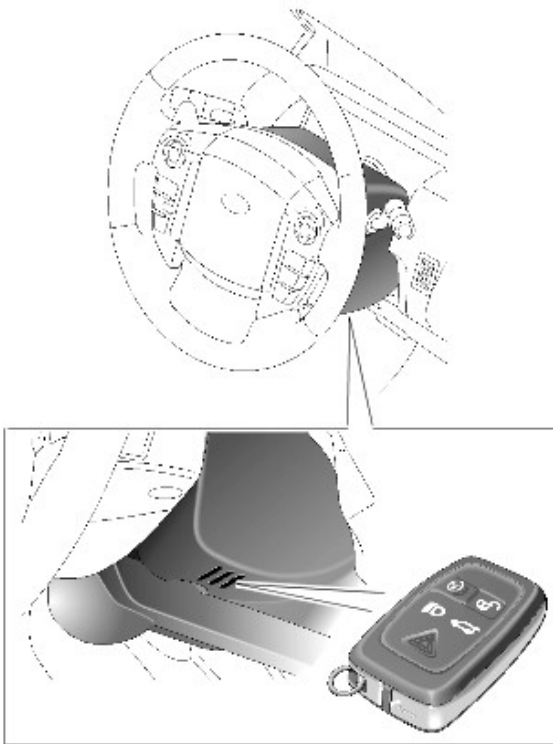

E129977

This process bypasses the data exchange between the KVM and the [CJB \(central junction box\)](#); this is an inductive process and will operate if the battery in the Smart Key is discharged. A transponder within the Smart Key is detected by the IAU. The IAU confirms the code output from the transponder and communicates this code confirmation with the [CJB](#) via a LIN (local interconnect network) bus connection. The [CJB](#) then initiates the vehicle start process in the normal manner.

## PASSIVE ENTRY SYSTEM

The passive entry system is controlled by the KVM and low frequency antennas in each door handle and one in the rear bumper; antennas are also strategically situated within the vehicle. When inside the vehicle, the antennas ensure the Smart Key is always within the active transmission zone of the antennas no matter where the Smart Key is placed inside the vehicle. For this reason the orientation and positioning of the antennas is critical to the correct functioning of the system.

The vehicle can be unlocked without the use of a key-blade or buttons on the Smart Key.

When an external door handle is grasped and the Smart Key is within one meter (3.3ft.) of the handle; the Smart Key receives a low-frequency signal transmitted from the handle.

The Smart Key responds with a radio frequency transmission of its authorization code. The radio frequency signal is received by the Radio-Frequency receiver and passed to the keyless vehicle module which checks and approves the code as valid.

The KVM then drives the fast latch directly to allow the door to be opened. The keyless vehicle module also transmits an unlock request to the [CJB](#). The [CJB](#) then passes an unlock request to the door modules.

Door-handle antenna operating area

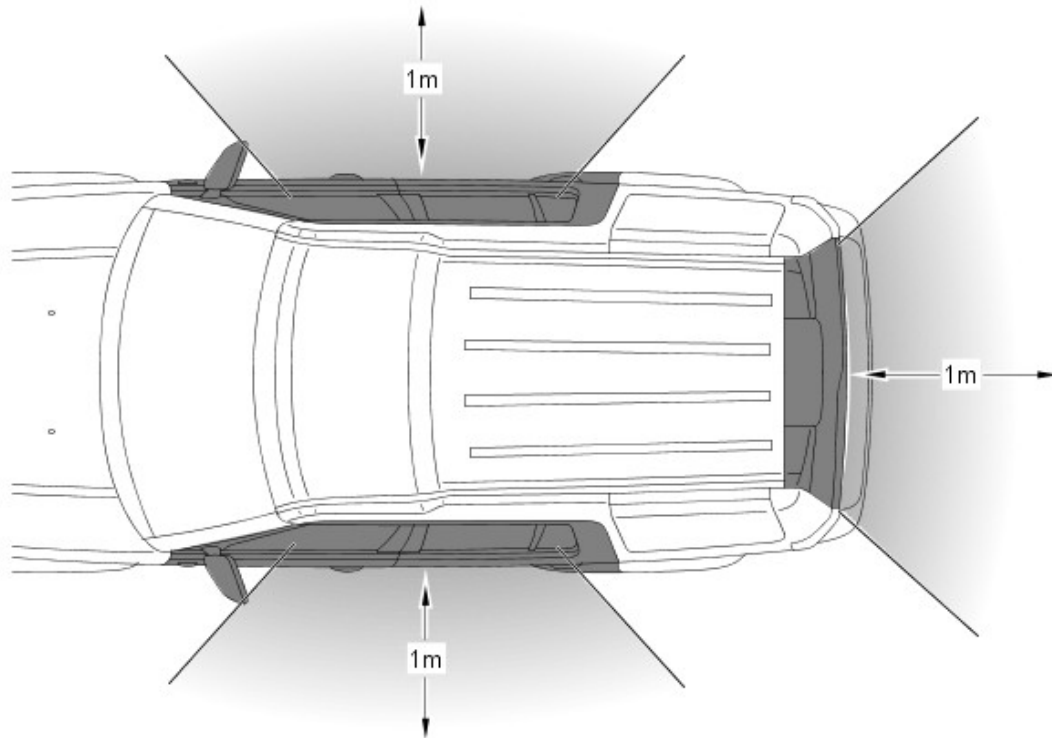

E117707

Locking of the vehicle is performed by pressing one of the buttons located on each exterior door handle, with the Smart Key within a one meter range of the vehicle. When the door handle button is pressed, the KVM transmits a low-frequency signal via the handle antenna to the Smart Key. The Smart Key transmits a radio frequency signal which is verified by the KVM and allows the doors to be locked or double locked and the alarm system to be armed.

To double lock the vehicle, the button on the exterior door handle must be pressed twice within three seconds, with the Smart Key within one meter range of the vehicle. If a door, hood or the tailgate door is ajar when an attempt to lock the vehicle is made, an error tone is emitted and no locking action will occur.

For additional information, refer to: [Anti-Theft - Active](#) (419-01A Anti-Theft - Active, Description and Operation).

When unlocking the vehicle using passive entry with single stage unlocking selected and a valid Smart key present, grasping the door handle will centrally unlock the vehicle. When the vehicle is configured for two stage unlocking and the drivers door handle is grasped with a valid Smart Key present only the drivers door will unlock, however if a passenger door handle is grasped with a valid Smart Key present the vehicle will centrally unlock.

- NOTE: Placing the key in a metallic container, a metal briefcase for example, may hinder its operation.
- NOTE: Passive locking will only activate if the key is outside the vehicle. If no key is present, two audible error warnings will sound.

To globally close the vehicle pressing and holding the button on the door handle locks the vehicle, arms the alarm and closes all open windows, not the sunroof. The windows will stop closing when the button is released.

### Capacitive Door Handle

The new exterior door operates using the following principle. A capacitive plate is molded internally within the handle, the vehicle exterior body acts as a second capacitive plate; air between the two acts as an insulator. The control electronics within the door handle evaluate the capacitance of the circuit, when a hand interrupts the space between the electrical field is altered and thus the capacitance of the capacitor. This signal is used to trigger the KVM to initiate the unlock process. This signal is calibrated so as not to detect false activations, for example, rain water or soiling.

- NOTE: Extreme water levels can trigger an unlock signal, for example, when washing a locked vehicle with a hose or high powered jet nozzle, providing the key is in the detection zone.

### CONTROL DIAGRAM

- NOTE: **A** = Hardwired; **F** = RF transmission; **N** = Medium Speed CAN; **W** = LF transmission; **AH** = Serial Communication Link

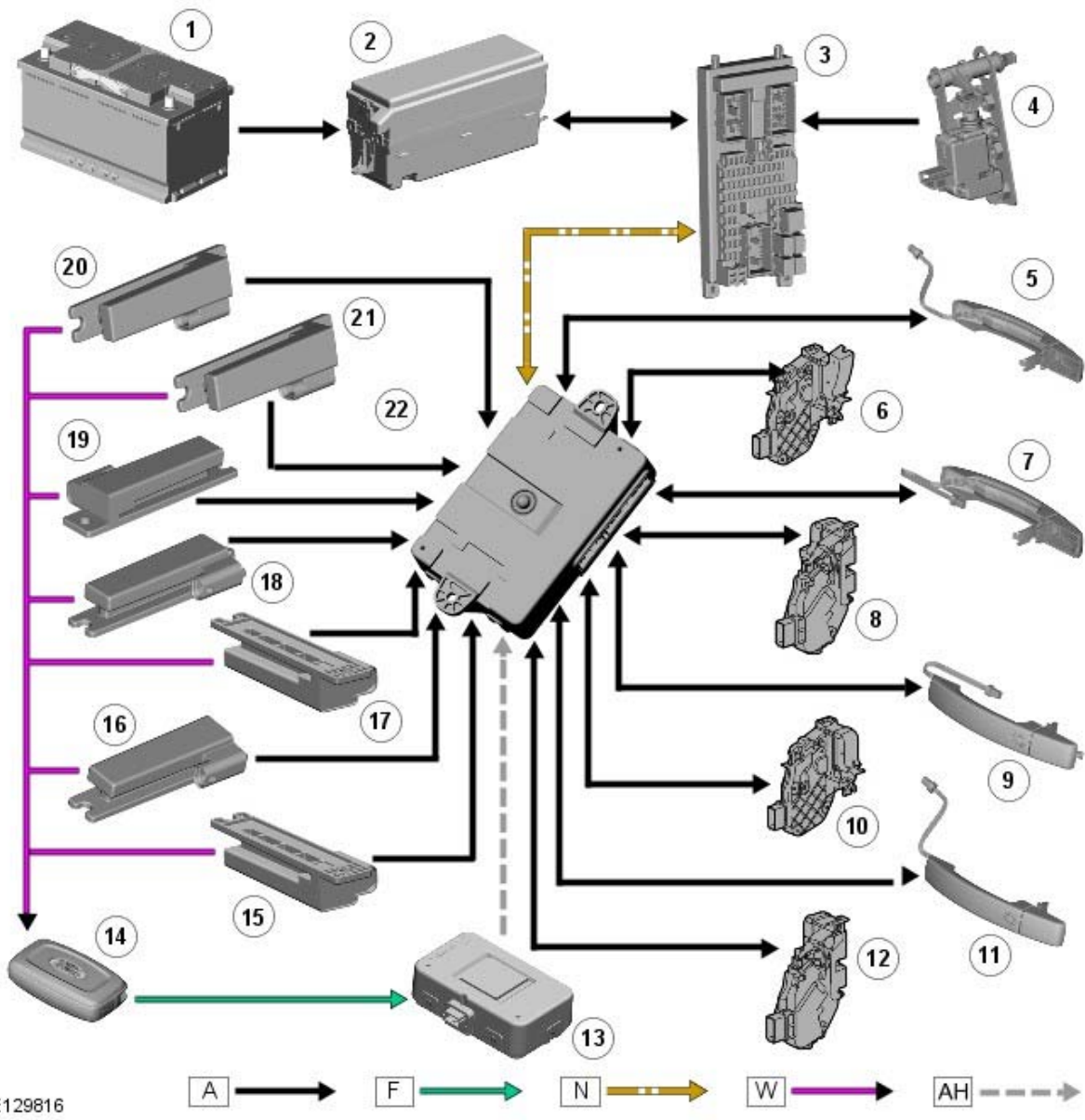

E129816



Item	Part Number	Description
1	-	Battery
2	-	EJB (engine junction box)
3	-	CJB
4	-	Tailgate release switch
5	-	Door handle, lock/unlock switch and antenna – right-hand-front
6	-	Door latch and fast latch - right-hand-front
7	-	Door handle, lock/unlock switch and antenna – left-hand-front
8	-	Door latch and fast latch - left-hand-front
9	-	Door handle, lock/unlock switch and antenna – right-hand-rear
10	-	Door latch and fast latch - right-hand-rear
11	-	Door handle, lock/unlock switch and antenna – left-hand-rear
12	-	Door latch and fast latch - left-hand-rear
13	-	Radio frequency receiver
14	-	Smart Key
15	-	Antenna
16	-	Antenna
17	-	Antenna
18	-	Antenna
19	-	Antenna
20	-	Antenna
21	-	Antenna
22	-	Keyless Vehicle Module

**PRINCIPLES OF OPERATION**

## Passive Entry - Locking/Unlocking Process

The vehicle unlocking procedure is carried out in the following way.

With the key within one meter of the approached door and the handle grasped a signal is sent to the KVM which responds with the following simultaneous actions:

- The KVM energizes the low frequency antenna in the door handle which transmits a 125 KHz signal to the key.
- On receipt of the low frequency signal the Smart Key transmits a radio frequency signal '433.92 MHz Europe' '315 MHz NAS / ROW' containing its authorization code to the RF (radio frequency) receiver.
- The RF receiver relays the code, via a serial communication line, to the KVM which checks and approves the code as valid.
  - The KVM will only respond if the radio frequency signal produced is from a valid key for the vehicle.
- The KVM transmits the unlock request to the [CJB](#) via the medium-speed [CAN \(controller area network\)](#) bus.
- The [CJB](#) confirms and sends the request, via the medium speed [CAN](#) bus, to the front door modules.
- The front door modules respond with the following simultaneous actions:
  - Drive the motors to unlock the front doors.
  - Transmit the door unlock request via a [LIN \(local interconnect network\)](#) data signal to the rear door modules.
- The rear door modules drive the motors to unlock the rear doors.
- When the door handle reaches 80 percent of its travel the handle clutch switch is closed and grounded sending a hardwired switched signal to the KVM.
- The KVM drives the fast latch release motors in the door latch assemblies releasing the door latches as the approached door handle is pulled through its full travel, the door can be opened.